

**INDUSTRIAL ELECTRONICS****SEM -IV (DEC -18)**

Q1)Solve Any 4:-

a)State and prove De-Morgans Theorem

[5]

Answer) De-Morgan suggested two theorems that an important part of Boolean Algebra. In the equation form they are as follows:-

1)

$$\overline{A \cdot B} = \bar{A} + \bar{B}$$

The complement of a product is equal to the sum of the compliments this is illustrated by truth table 4.2.2

A	B	$\overline{A \cdot B}$	$\bar{A} + \bar{B}$
0	0	1	1
0	1	1	1
1	0	1	1
1	1	0	0

Table 4.2.2 Truth table

CS Scanned with CamScanner

2)

$$\overline{A + B} = \bar{A} \cdot \bar{B}$$

The complement of a sum is equal to the product of the compliments. The truth table 4.2.3 shown illustrates this law

A	B	$\overline{A + B}$	$\bar{A} \cdot \bar{B}$
0	0	1	1
0	1	0	0
1	0	0	0
1	1	0	0

Table 4.2.3 Truth table

CS Scanned with CamScanner

a) Draw the characteristics of power BJT, power MOSFET and IGBT [5]

Answer)

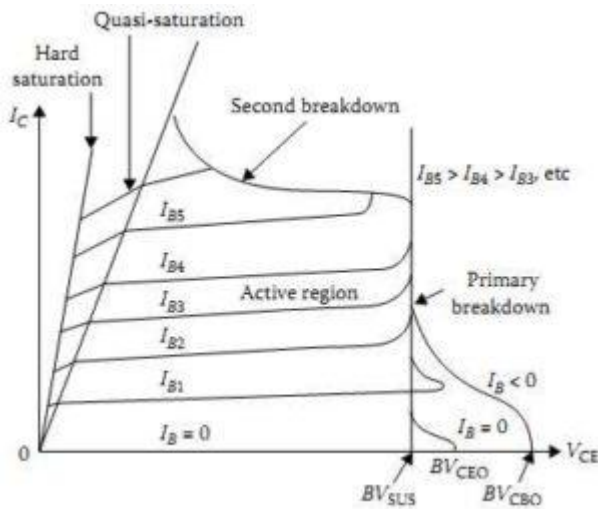

V-I CHARACTERISTIC OF BJT

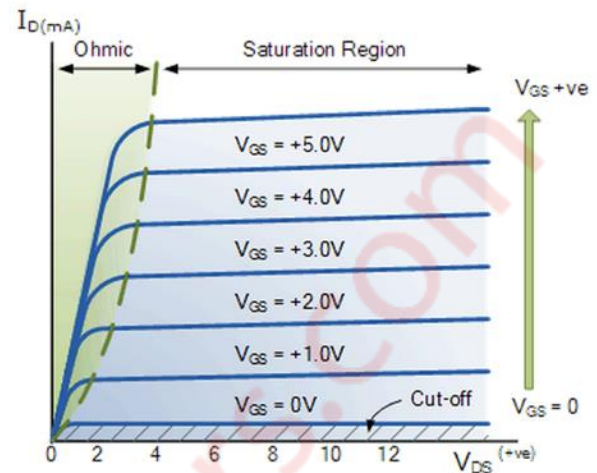

V-I CHARACTERISTIC OF MOSFET

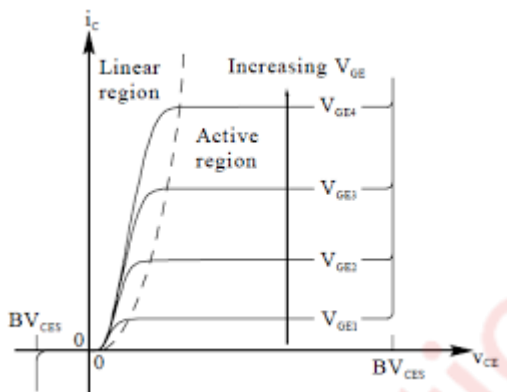

V-I CHARACTERISTIC OF IGBT

c) Mention the importance of instrumentation amplifier and voltage follower? [5]

Answer) Importance of Instrumentation Amplifier:-

An **Instrumentation amplifier** is a type of differential amplifier that has been outfitted with input buffer amplifiers, which eliminate the need for input impedance matching and thus make the amplifier particularly suitable for use in measurement and test equipment. Additional

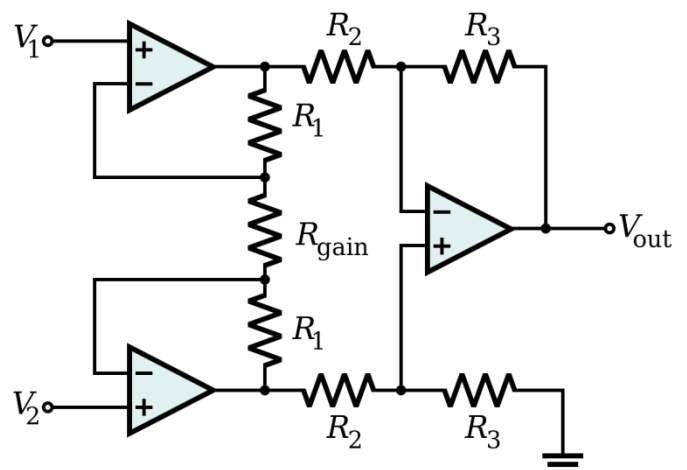

characteristics include very low DC offset, low drift, low noise, very high open-loop gain, very high common-mode rejection ratio, and very high input impedances. Instrumentation amplifiers are used where great accuracy and stability of the circuit both short and long-term are required.

**Importance of Voltage Follower:-** A **Voltage Follower** is an op-amp circuit which has a voltage gain of 1. This means that the op amp does not provide any amplification to the signal. The reason it is called a voltage follower is because the output voltage directly follows the input voltage, meaning the output voltage is the same as the input voltage. Thus, for example, if 10V goes into the op amp as input, 10V comes out as output. A voltage follower acts as a buffer, providing no amplification or attenuation to the signal. An op amp circuit is a circuit with a very high input impedance. This high input impedance is the reason voltage followers are used. Also, Voltage Followers Draw Very Little Current and Voltage Followers Are Important in Voltage Divider Circuits.

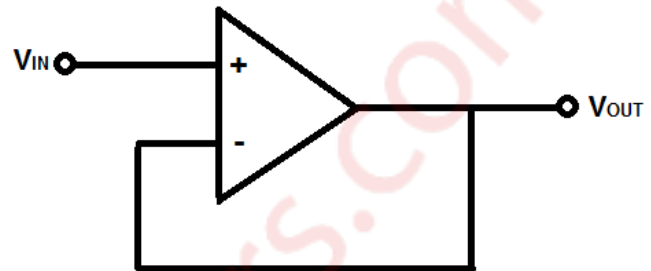

**d) Compare AC and DC Motors**

[5]

**Answer)**

AC Motors	DC Motors
Ac motors are powered from AC current.	DC motors are powered from DC current
In AC motors conversion of current is not required.	In DC motors conversion of current is required like ac into dc current.
AC motors are used where power performance is sought for extended periods of time.	DC motors are used where motor speed required to be controlled externally
AC motors can be single-phase or three phases.	All DC motors are single phase.
In AC motors Armatures do not rotate while magnetic field continuously rotates.	In DC motors, the armature rotates while the magnetic field does rotate.
In AC motors Armatures do not rotate while magnetic field continuously rotates.	In DC motors, the armature rotates while the magnetic field does rotate.

e) Explain basic principle of single phase inverter

[5]

**Answer) Single Phase Inverter:-**

In this circuit four switches are used and the DC supply centre-tap is not required. Switches Q1 and Q2 are switched together while switches Q3 and Q4 are switched together alternately to Q1 and Q2 in a complementary manner. The four feedback diodes D1-D4 conduct currents as indicated in the figure below.

The output load voltage alternates between  $+V_s$  when Q1 and Q2 are on and  $-V_s$  when Q3 and Q4 are on, irrespective of the direction of current flow. It is assumed that the load current does not become discontinuous at any time. In the following analysis we assume that the load current does not become discontinuous at any time, same as for the half-bridge circuit.

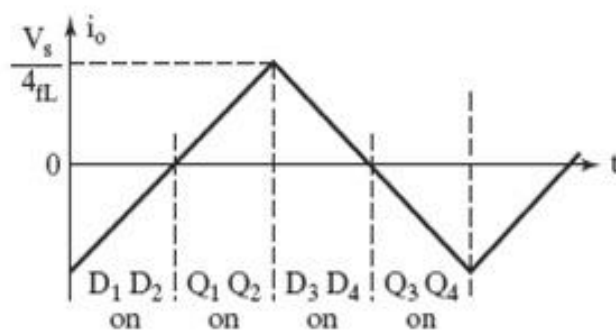
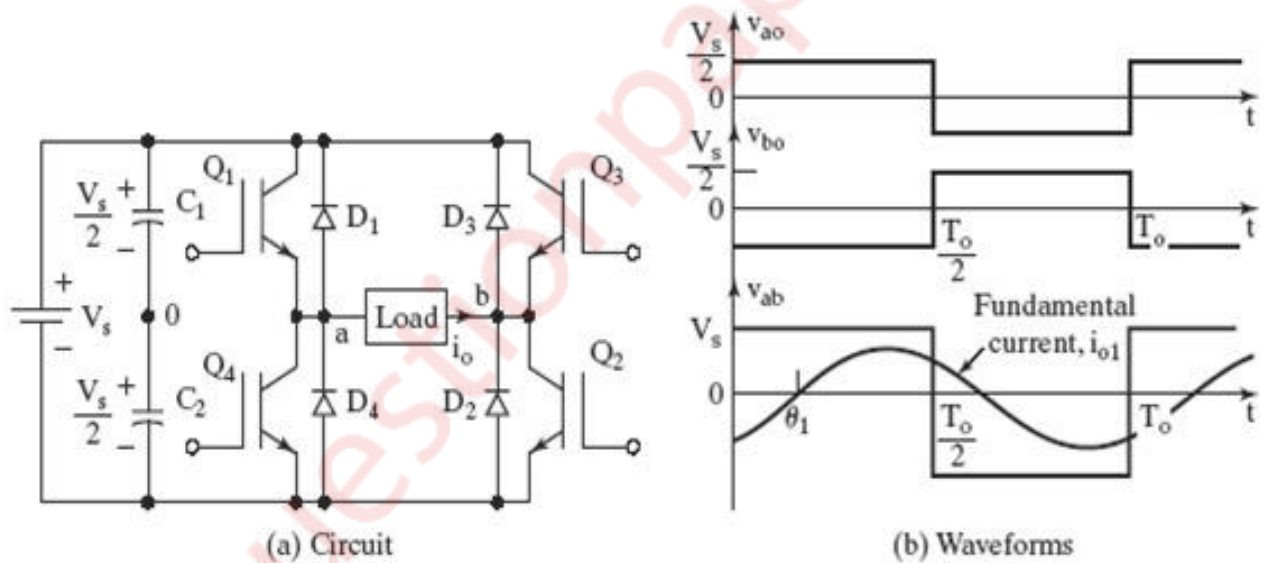

(c) Load current with highly inductive load

**Q2)a) Draw and explain block diagram of closed loop speed control of DC Motor [7]**

**Answer) Closed loop speed control with inner loop current control:-**

In the circuit (without current control) the speed control output directly changes the terminal voltage of the DC motor. But in DC motor, the armature resistance and armature impedance are very small and thus the time constant is also very less. Due to this less time constant for a small increase in terminal voltage, the armature current increases drastically. This quick high armature current may damage the solid state devices used in the power converter. To avoid this, the armature current should be increased slowly to produce the required torque. This can be obtained by placing a current control loop in between the speed control and power converter as shown in figure.

Here the speed output signal generates a corresponding armature current signal and this signal is compared with the existing armature fed back to the comparator circuit. The difference in the current drives the current loop controller and produces a control signal to the power converter. This introduces a very smooth increase in terminal voltage and thus the armature current by providing a dual controller. The current controller can be proportional or proportional integral (PI) controller. Most probably PI controller is used because of less steady state error and smooth response compared to proportional controller.

• **Advantages of closed loop speed control:-**

- Greater accuracy with fine control of speed
- Improved dynamic response
- The motor can be operated at constant torque and constant speed
- Stabilized operation with out any major deviations
- Circuit protections also can be incorporated in the closed loop speed control.

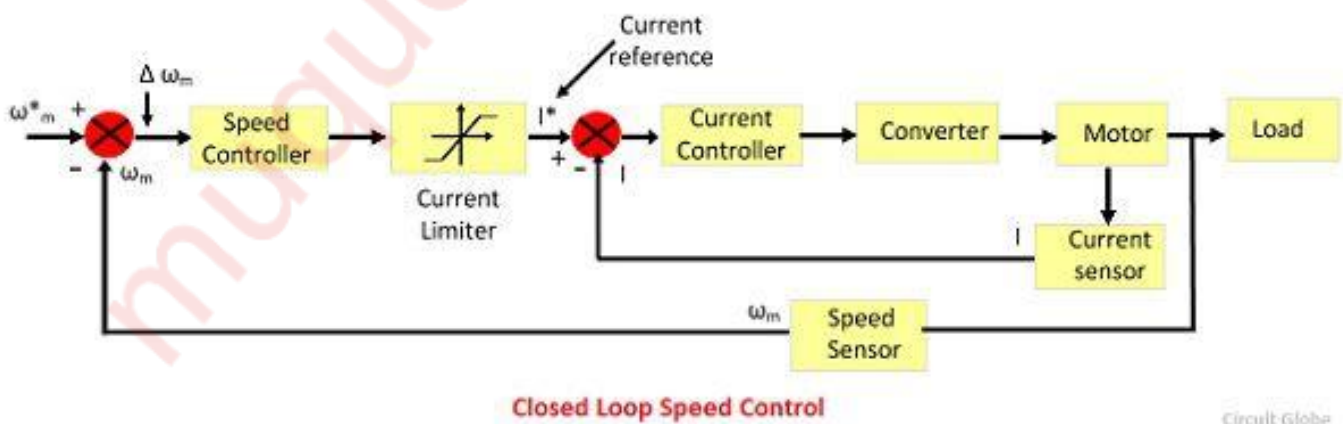



**b) Write a short note on selection of motors for various industrial applications [7]**

**Answer)** There are various industrial applications for which A.C. or D.C. drives are used. Some of them are tabulated below:-

Sr.No.	Application	Requirement	Type of motor
1	Centrifugal pumps	Moderate starting torque without speed control	Standard squirrel cage
2	Reciprocating pumps	100 to 200% rated torque without speed control	Slip ring motor
3	Crushers, punch presses, power hammers	Heavy starting torque and high peak loads	High torque squirrel cage or slip ring induction motor
4	Stirrer for liquids	Light starting duty	squirrel cage or slip ring induction motor
5	Large ships	Large power demand	Synchronous or slip ring induction motor
6	Pulp grinders, load conveyors, line shafts	On load starting, high starting torque	High torque squirrel cage or slip ring induction motor
7	Machine tools	Fast acceleration, frequent starts and stops, fast response	Squirrel cage motor
8	Domestic appliances mixers, sewing machine, vacuum cleaners	Simple speed control	Universal motor
9	Domestic refrigerator, compressor, A.C.	Good Starting Torque	Single phase capacitor start induction motor
10	Reciprocating compressors	Starting with partial load	Slip ring induction motor

c) Compare SCR and TRIAC  
 Answer)

[6]

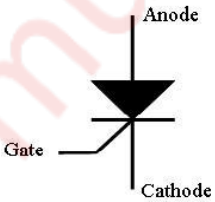
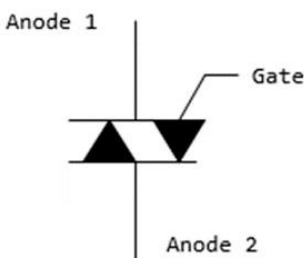
<u>SCR</u>	<u>TRIAC</u>
SCR stands for silicon controlled rectifier.	TRIAC stands for triode for alternating current.
The SCR is unidirectional device.	The TRIAC is bidirectional device.
It available in large ratings.	It available in smaller ratings.
The SCR control DC power.	The TRIAC control DC as well as AC power.
The SCR can be triggered by positive gate voltage only.	The TRIAC can be triggered either by positive or negative gate voltage.
In SCR, only one mode of operation is possible.	In TRIAC, four different modes of operation is possible.
It is more reliable.	It is less reliable.
The SCR conduct current in one direction only.	The TRIAC conduct current in both the directions.
It needs two heat sink.	It needs only one heat sink
	
MUQuestionPapers.com	

**Q3)a) With neat circuit diagram and waveforms, explain single phase full wave half controlled rectifier circuit supplying a resistive load [7]**

**Answer)** The semiconverter has two SCRs T1 and T2. There are two diodes D1 and D2. The input is 230 V 50 Hz AC supply. The output  $V_0$  of the semiconverter is DC. The load 'R' is connected across the output.

In the positive half cycle of the supply, SCR T1 and diode D2 are forward biased. SCR T1 is triggered at firing angle  $\alpha$ . Current flows through the load.

The equivalent circuit is shown below.

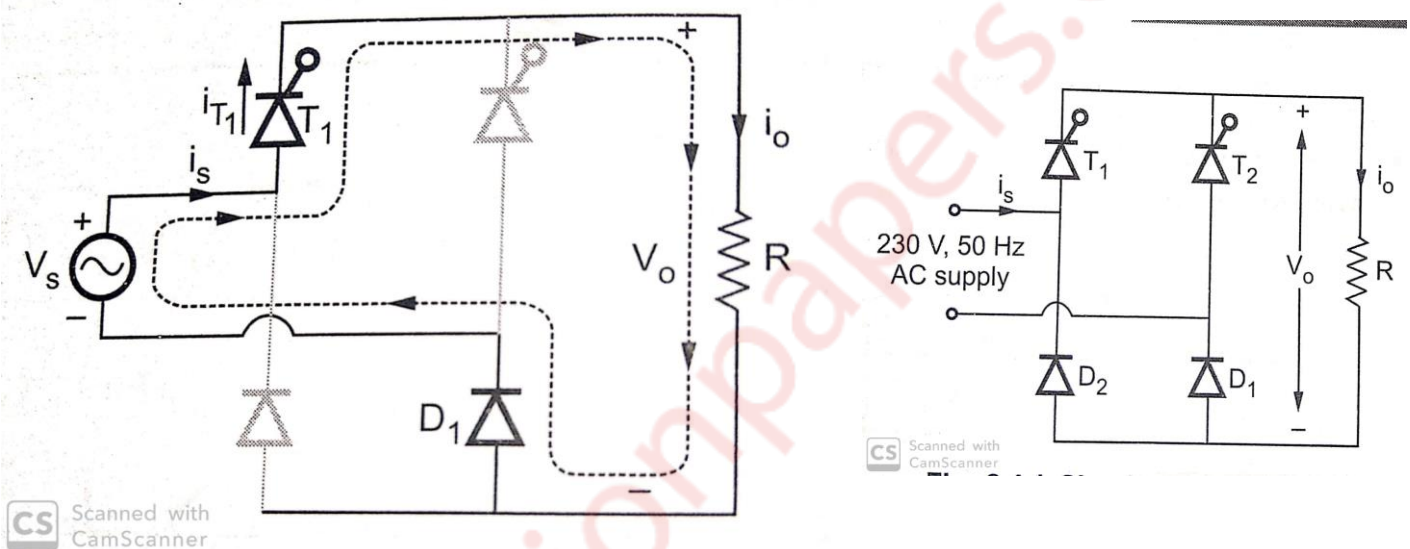

**Figure :- Circuit Diagram of single phase half controlled rectifier**

From the above figure, it is clear that, when T1 -D1 conducts,

$$V_0 = V_s \text{ (i.e. supply voltage)}$$

$$\text{And } i_0 = v_0/R = V_s/R$$

Fig. shows the waveforms of this circuit. The waveform of  $V_0$  is same as supply voltage  $V_s$ , when T1 -D1 conducts. Since the load is resistive, the output current waveform is same as voltage waveform. This is because,

$$i_0 = v_0/R$$

Thus, amplitude of  $V_0$  is only reduced by the factor 'R' to give  $i_0$ . But the shape of the current waveform does not change. In the Fig. observe that  $i_{T1}$  is the SCR T1 current, and  $I_s$  is the supply current. Basically  $i_0$ ,  $i_{T1}$  and  $I_s$  is the same current. Hence, These currents are in the same direction and flow in the Same loop. The waveforms of these currents are also shown in Fig. Below.



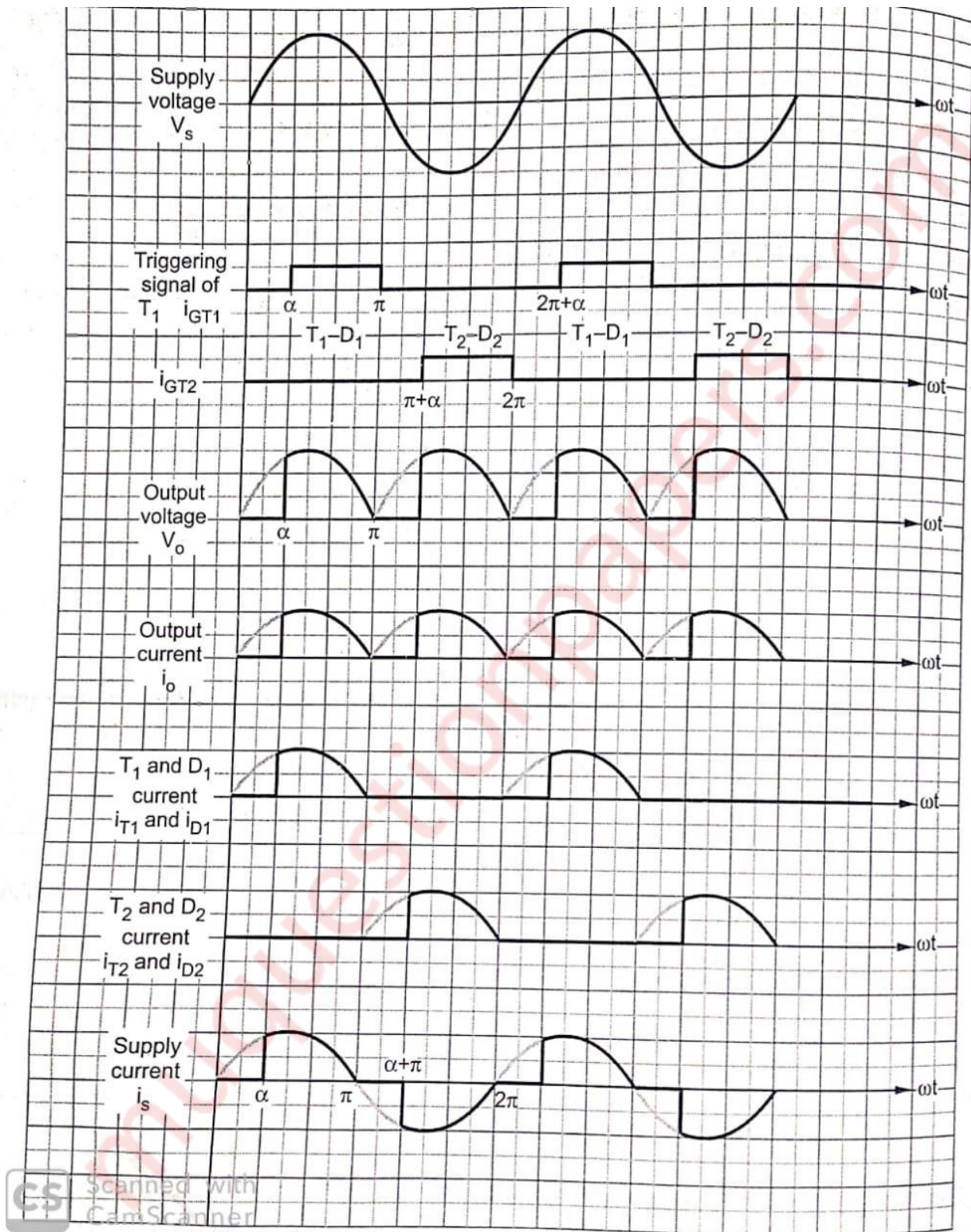
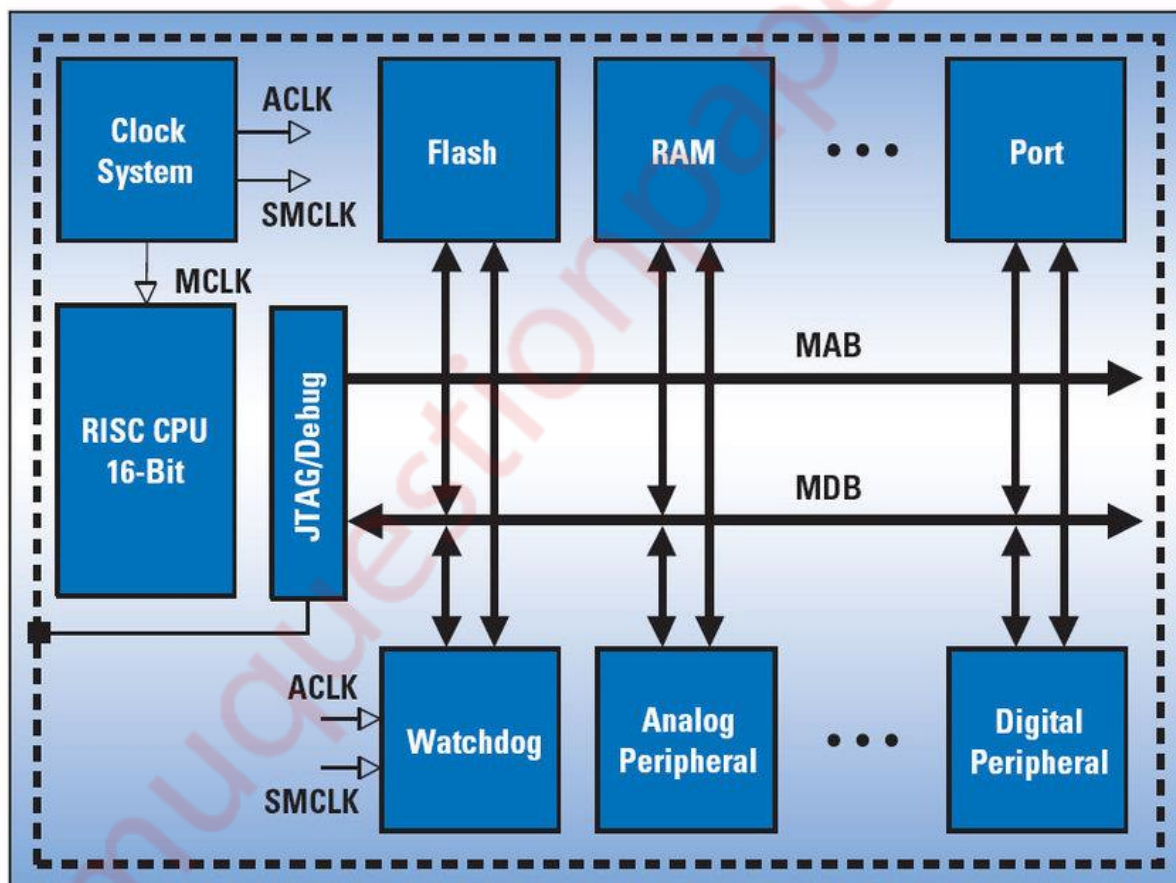

**Figure:- Waveforms of single phase half controlled rectifier with R load**

b) Draw and explain architecture of MSP430 Microcontroller [7]

**Answer) Architecture of MSP430 Microcontroller**

The MSP430 is a family of 16-bit RISC microcontrollers produced by Texas Instruments. The MSP430 microcontroller was developed at Texas Instruments in 1993. At the beginning, Texas Instruments only offered the MSP430 in Europe. Since 1997, the MSP430 microcontroller family is offered world wide. The most important feature of the MSP430 is its low power consumption. However, the flexibility of its peripheral modules and the easy way to use it is the reason why this microcontroller is also used as a general purpose microcontroller.



**FIGURE:- ARCHITECTURE OF MSP430 MICROCONTROLLER**

The MSP430 microcontroller is based on a von-Neumann architecture. The MSP430 von-Neumann architecture has one address space shared with special function registers (SFRs), peripheral control registers, RAM, and Flash/ROM memory. At the moment, there are two compatible CPUs existing within the MSP430 microcontroller family. The MSP430 CPU uses 16-bit CPU register and 16-bit Program Counter.

This basically means that with such a CPU an address range of 64kBytes could be addressed. Due to the von-Neumann architecture, the address range covers peripheral control registers (address 0x0000 to 0x01FF), RAM (starting at address 0x0200), and for example Flash memory (e.g. for an MSP430F169 the Flash memory starts at address 0x1000). So the MSP430 derivatives with the MSP430 CPU usually have a maximum Flash memory of 60KByte. The other CPU is the MSP430 CPU<sub>x</sub> (or MSP430X). This is an extended CPU. The CPU registers are 20-bit registers. Also the Program Counter is a 20-bit register, which allows to address memory above the 64KByte limit. Usually all MSP430s with a Flash memory above 60kByte Flash have the CPU<sub>x</sub>. Because the CPU<sub>x</sub> is based on MSP430 CPU the software that was written on a MSP430 CPU device is also running on MSP430 CPU<sub>x</sub> chips.

### **Features Of MSP430 Microcontroller:-**

- These are some features of MSP430.
- It is available in a 20 pin plastic small outline widebody package.
- Its operating voltage range is 2.5v to 5.5v. Its active mode is 330  $\mu$ A at 1 MHz, 3 V.
- Its stands by mode are 1.5  $\mu$ A. It's off mode (Ram Retention) is 0.1  $\mu$ A.
- It has serial onboard programming.

c) Describe in detail low pass filter

[6]

**Answer) Low Pass Filter:-**

A low pass filter is a filter which passes low-frequency signals and blocks, or impedes, high-frequency signals.

In other words, low-frequency signals go through much easier and with less resistance and high-frequency signals have a much harder getting through, which is why it's a low pass filter.

Low pass filters can be constructed using resistors with either capacitors or inductors. A low pass filter composed of a resistor and a capacitor is called a low pass RC filter. And a low pass filter with a resistor and an inductor is called a low pass RL filter.

Both RC and LC low pass filters circuits have the effect of passing through low frequency signals while impeding high-frequency ones.

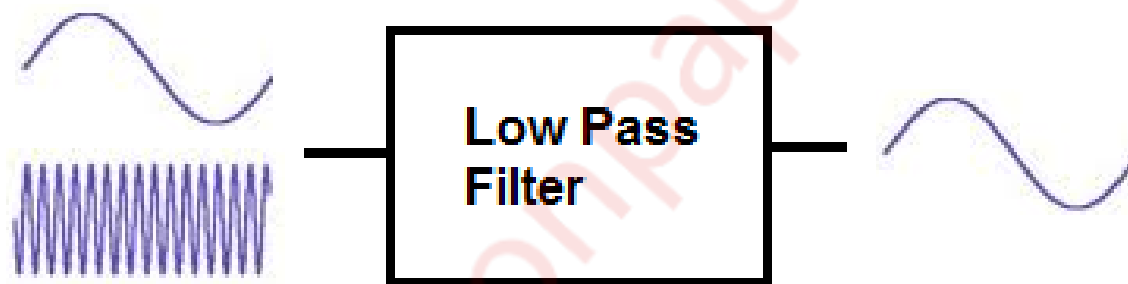

**Figure :- Low Pass Filter**

**Types :-**

- 1) Low Pass RC Filter
- 2) Low Pass RL Filter

**Applications:-**

1. An RC circuit is used as a Low Pass Filter- Analog, CR as a High Pass.
2. RC circuit acts as an integrator also, which means that LPF is also acting like a **integrator**.



3. In Multirate Digital Signal Processing, when implementing an **Interpolator**, it is used as an **Anti - Imaging Filter** and when implementing **Decimator** it is used as **Anti - Aliasing Filter - Major application.**
4. Used in **Audio Applications** for **Equalization** purposes.
5. Used in Receivers such as **Superheterodyne** etc for efficient reception of the baseband signals.

**Q4)a) Draw circuit diagram and waveforms of 3 phase bridge inverter with R load ( 180 degree mode of conduction) [7]**

**Answer)**

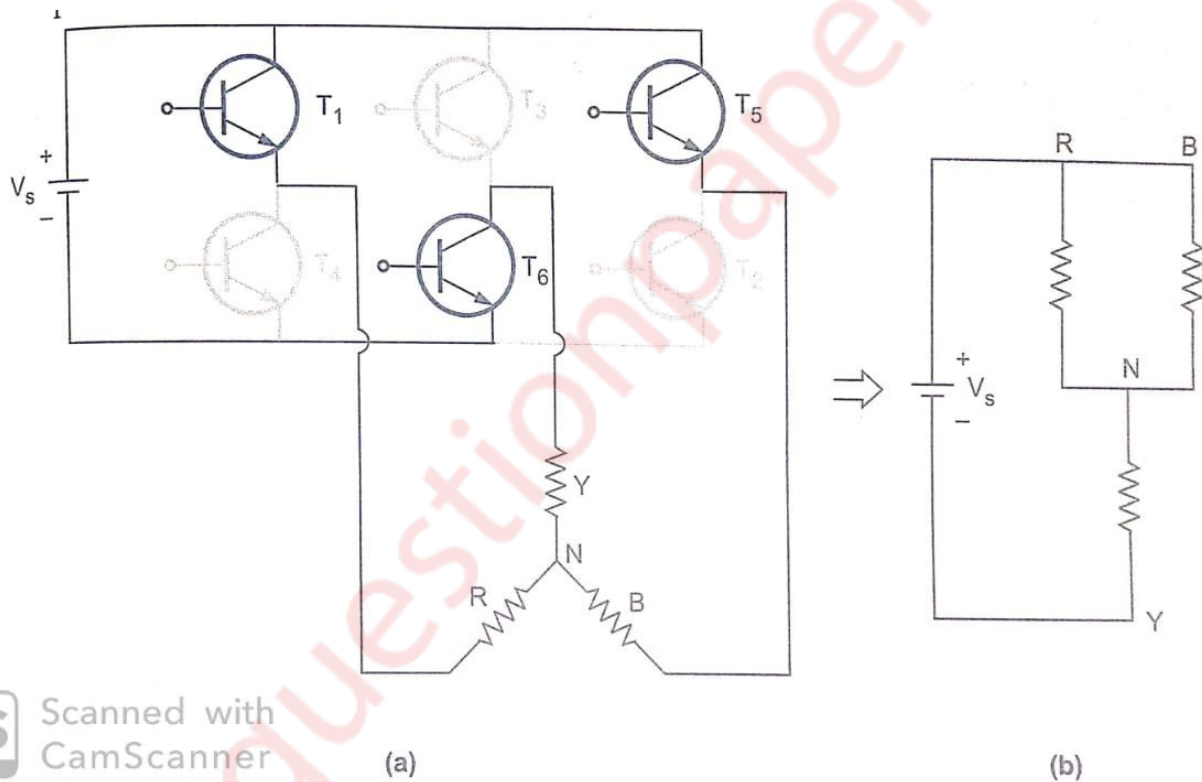

- **FIGURE:- CIRCUIT DIAGRAM FOR 180 DEGREE CONDUCTION TYPE 3 PHASE INVERTER**



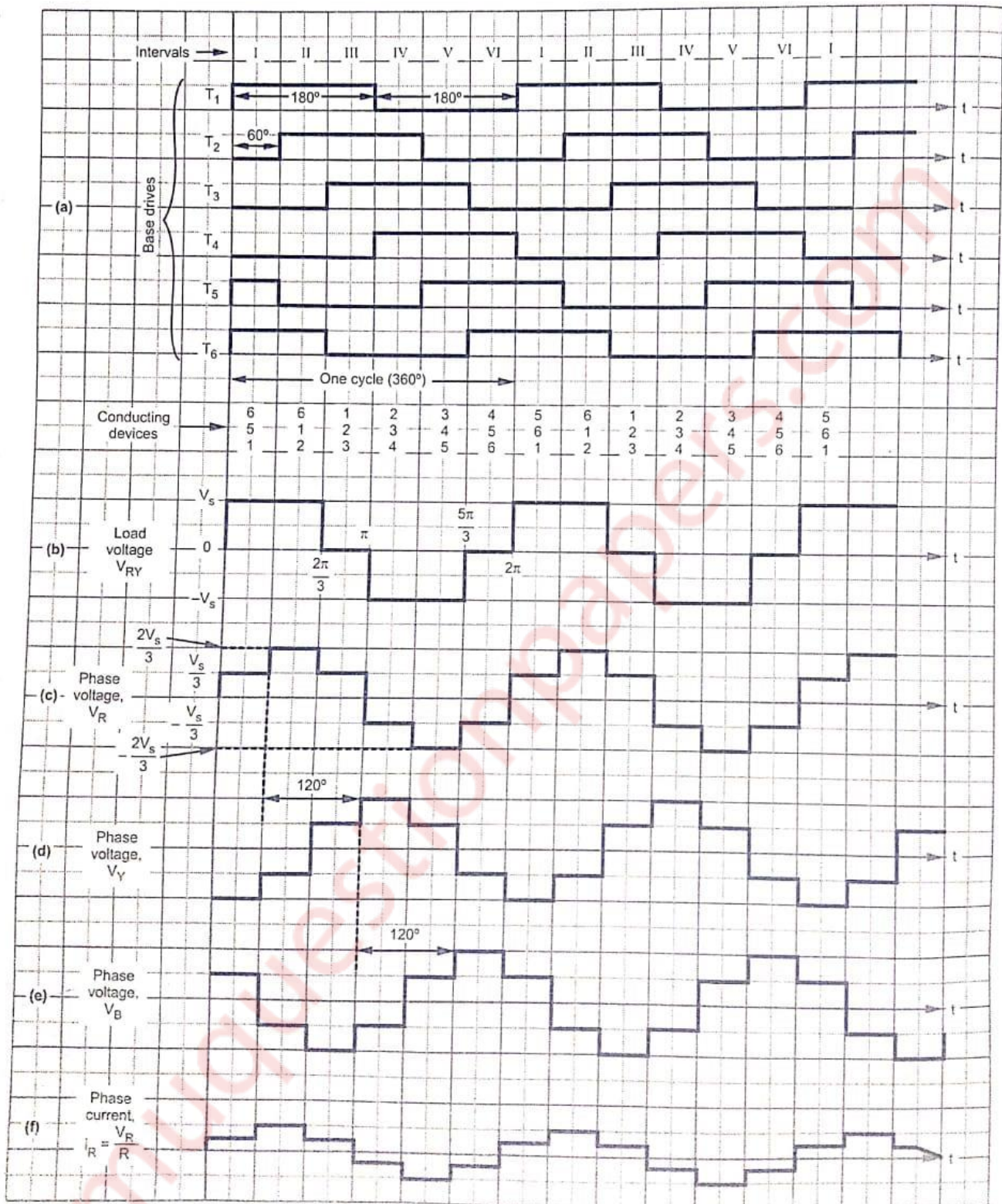

Scanned with

CamScanner Fig. 2.9.3 Waveforms of 180° mode inverter

b) Explain the working principle of GTO with neat diagram [7]

Answer) Working Principle Of GTO:-

The turn ON operation of GTO is similar to a conventional thyristor. When the anode terminal is made positive with respect to cathode by applying a positive gate current, the hole current injection from gate

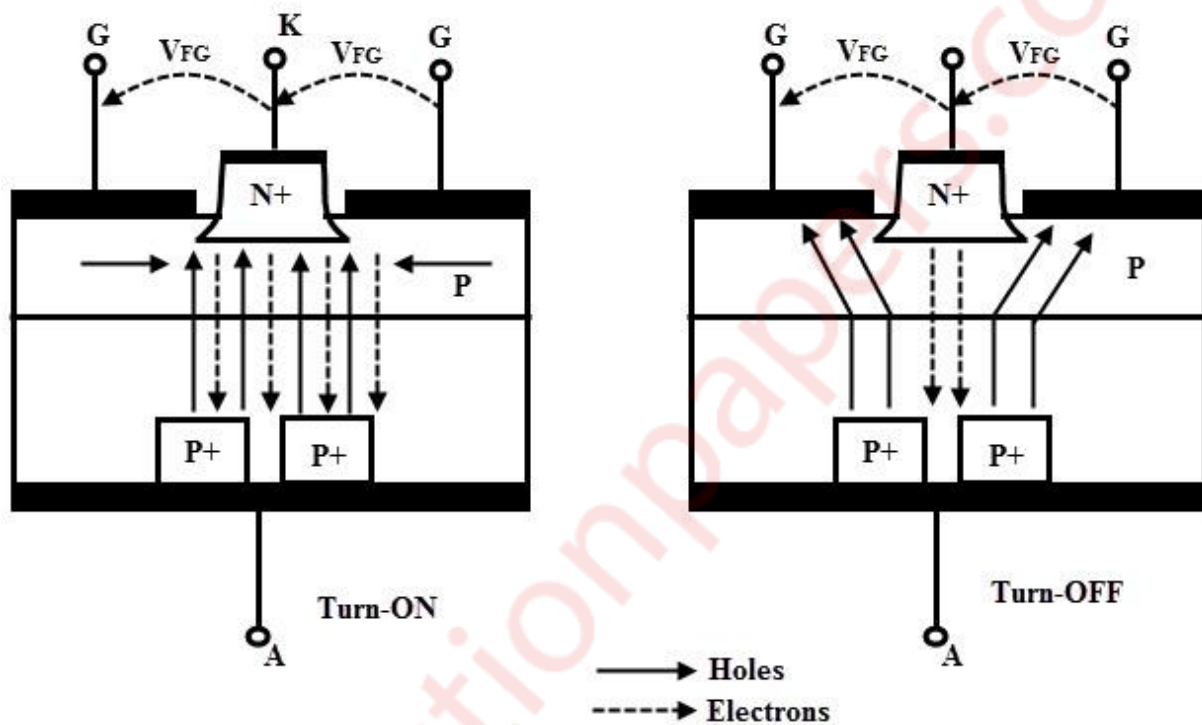

forward bias the cathode p-base junction.

**FIGURE :- WORKING PRINCIPLE OF GTO**

This results in the emission of electrons from the cathode towards the anode terminal. This induces the hole injection from the anode terminal into the base region. This injection of holes and electrons continuous till the GTO comes into the conduction state.

In case of thyristor, the conduction starts initially by turning ON the area of cathode adjacent to the gate terminal. And thus, by plasma spreading the remaining area comes into the conduction.

Unlike a thyristor, GTO consists of narrow cathode elements which are heavily interdigitated with gate terminal, thereby initial turned ON area is very large and plasma spreading is small. Hence the GTO comes into the Conduction state very quickly.

To turn OFF a conducting GTO, a reverse bias is applied at the gate by making the gate negative with respect to cathode. A part of the holes from the P base layer is extracted through the gate which suppress the injection of electrons from the cathode.

In response to this, more hole current is extracted through the gate results more suppression of electrons from the cathode. Eventually, the voltage drop across the p base junction causes to reverse bias the gate cathode junction and hence the GTO is turned OFF.

During the hole extraction process, the p-base region is gradually depleted so that the conduction area squeezed. As this process continuous, the anode current flows through remote areas forming high current density filaments. This causes local hot spots which can damage the device unless these filaments are extinguished quickly.

By the application of high negative gate voltage these filaments are extinguished rapidly. Due to the N base region stored charge, the anode to gate current continues to flow even though the cathode current is ceased. This is called a tail current which decays exponentially as the excess charge carriers are reduced by the recombination process. Once the tail current reduced to a leakage current level, the device retains its forward blocking characteristics.

**C) Compare Monostable and Astable Multivibrators****[6]****Answer)**

<b>Monostable Multivibrators</b>	<b>Astable Multivibrators</b>
1. It has only one stable state	1. There is no stable state.
2. Trigger is required for the operation to change the state.	2. Trigger is not required to change the state hence called free running.
3. Two comparators R and C are necessary with IC 555 to obtain the circuit.	3. Three components $R_A$ , $R_B$ and C are necessary with IC 555 to obtain the circuit.
4. The pulse width is given by $T=1.1RC$ Seconds.	4. The frequency is given by, $F_o=1/T=1.45/(R_A+2R_B)C$
5. The frequency of Operation is controlled by frequency of trigger pulses applied.	5. The frequency of operation is controlled by $R_A$ , $R_B$ & C.
6. The applications are timer, frequency divider, pulse width modulation etc.	6. The applications are square wave generator, flasher, voltage controlled oscillator, FSK Generator etc.

**Q5)a) Explain UJT Triggering method of SCR****[7]**

**Answer)** One common application of the **Uni Junction Transistor** is the triggering of the other devices such as the SCR, triac etc. The basic elements of such a triggering circuit are shown in figure. The resistor  $R_E$  is chosen so that the load line determined by  $R_E$  passes through the device characteristic in the negative resistance region, that is, to the right of the peak point but to the left of the valley point, as shown in figure. If the load line does not pass to the right of the peak point P, the device cannot turn on.



For ensuring turn-on of UJT

$$R_E < V_{BB} - V_p / I_p$$

This can be established as below,

Consider the peak point at which  $I_{RE} = I_p$  and  $V_E = V_p$

(the equality  $I_{RE} = I_p$  is valid because the charging current of capacitor, at this instant is zero, that is, the capacitor, at this particular instant, is changing from a charging state to a discharging state).

$$\text{Then } V_E = V_{BB} - I_{RE} R_E$$

$$\text{So, } R_{E(MAX)} = V_{BB} - V_E / I_{RE} = V_{BB} - V_p / I_p \text{ at the peak point.}$$

**At the valley point,  $V$**

$I_E = I_V$  and  $V_E = V_V$  so that

$$V_E = V_{BB} - I_{RE} R_E$$

$$\text{So } R_{E(MIN)} = V_{BB} - V_E / I_{RE} = V_{BB} - V_V / I_V \text{ or for ensuring turn-off.}$$

$$R_E > = V_{BB} - V_V / I_V$$

So, the range of resistor  $R_E$  is given as,

$$V_{BB} - V_p / I_p > R_E > V_{BB} - V_V / I_V$$

The resistor  $R$  is chosen small enough so as to ensure that SCR is not turned on by voltage  $V_R$  when emitter terminal  $E$  is open or  $I_E = 0$

**The voltage  $V_R = R V_{BB} / R + R_{BB}$  for open-emitter terminal.**

The capacitor  $C$  determines the time interval between triggering pulses and the time duration of each pulse. By varying  $R_E$ , we can change the time constant  $R_E C$  and alter the point at which the UJT fires. This allows us to control the conduction angle of the SCR, which means the control of load current.



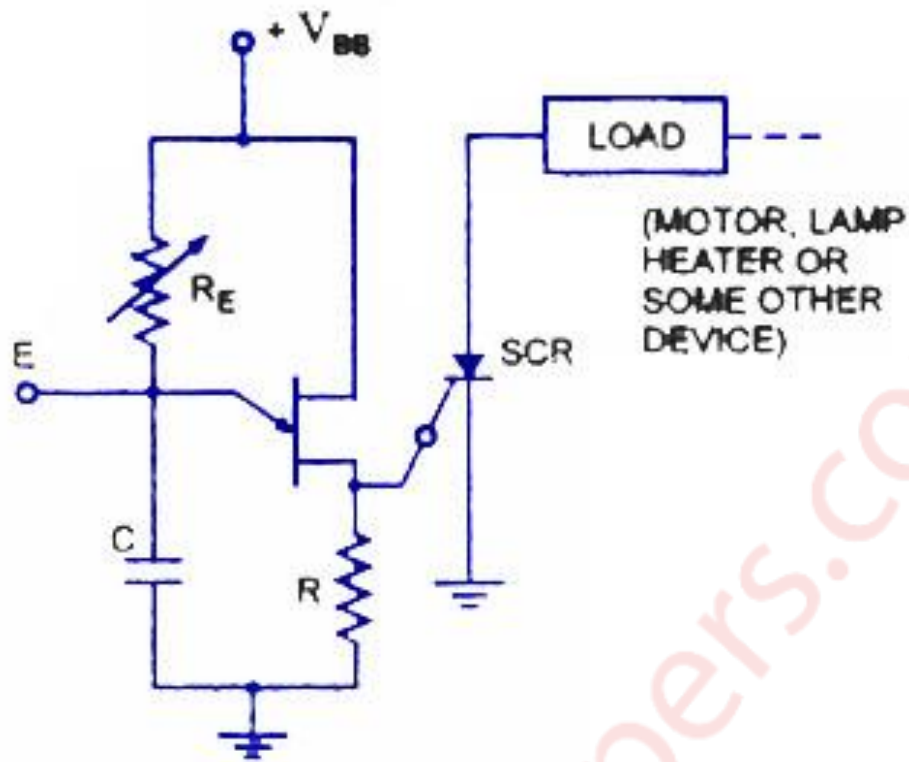

*UJT Triggering of An SCR*

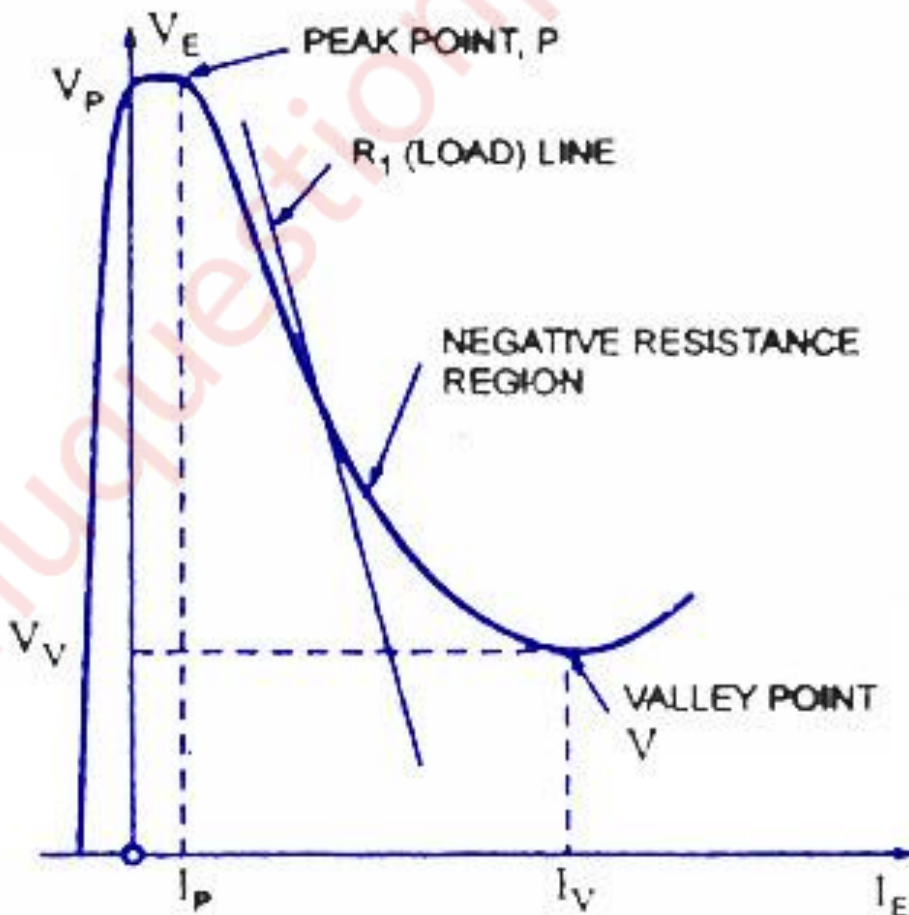

**b) what is a flipflop? Explain different types of flipflops?**

**[7]**

**Answer)** In electronics, a *flip-flop* is a special type of gated latch circuit.

In electronics, a **flip-flop** or **latch** is a circuit that has two stable states and can be used to store state information – a bistable multivibrator. The circuit can be made to change state by signals applied to one or more control inputs and will have one or two outputs. It is the basic storage element in sequential logic. Flip-flops and latches are fundamental building blocks of digital electronics systems used in computers, communications, and many other types of systems.

Flip-flops and latches are used as data storage elements. A flip-flop is a device which stores a single *bit* (binary digit) of data; one of its two states represents a "one" and the other represents a "zero". Such data storage can be used for storage of *state*, and such a circuit is described as sequential logic in electronics. When used in a finite-state machine, the output and next state depend not only on its current input, but also on its current state (and hence, previous inputs). It can also be used for counting of pulses, and for synchronizing variably-timed input signals to some reference timing signal.

There are several different types of flip-flops. The most common types of flip flops are:

- **SR flip-flop:** Is similar to an SR latch. Besides the CLOCK input, an SR flip-flop has two inputs, labeled SET and RESET. If the SET input is HIGH when the clock is triggered, the Q output goes HIGH. If the RESET input is HIGH when the clock is triggered, the Q output goes LOW.

In an SR flip-flop, the SET and RESET inputs shouldn't both be HIGH when the clock is triggered. This is considered an invalid input condition, and the resulting output isn't predictable if this condition occurs.

- **D flip-flop:** Has just one input in addition to the CLOCK input. This input is called the DATA input. When the clock is triggered, the Q output is matched to the DATA input. Thus, if the DATA input is HIGH, the Q output goes HIGH, and if the DATA input is LOW, the Q output goes LOW.

Most D-type flip-flops also include S and R inputs that let you set or reset the flip-flop. The S and R inputs in a D flip-flop ignore the CLOCK input. Thus, if you apply a HIGH to either S or R, the flip-flop will be set or reset immediately, without waiting for a clock pulse.

- **JK flip-flop:** A common variation of the SR flip-flop. A JK flip-flop has two inputs, labeled J and K. The J input corresponds to the SET input in an SR flip-flop, and the K input corresponds to the RESET input.

The difference between a JK flip-flop and an SR flip-flop is that in a JK flip-flop, both inputs can be HIGH. When both the J and K inputs are HIGH, the Q output is *toggled*, which means that the output alternates between HIGH and LOW.

For example, if the Q output is HIGH when the clock is triggered and J and K are both HIGH, the Q output is set to LOW. If the clock is triggered again while J and K both remain HIGH, the Q output is set to HIGH again, and so forth, with the Q output alternating from HIGH to LOW at every clock tick.

- **T flip-flop:** This is simply a JK flip-flop whose output alternates between HIGH and LOW with each clock pulse. Toggles are widely used in logic circuits because they can be combined to form counting circuits that count the number of clock pulses received.

You can create a T flip-flop from a D flip-flop by connecting the **Q-bar** output directly to the D input. Thus, whenever a clock pulse is received, the current state of the Q output is inverted (that's what the **Q-bar** output is) and fed back into the D input. This causes the output to alternate between HIGH and LOW.

You can also create a T flip-flop from a JK flip-flop simply by hard-wiring both the J and K inputs to HIGH. When both J and K are HIGH, the JK flip-flop acts as a toggle.

**c)Compare Microprocessor and Microcontroller**

**[6]**

**Answer)**

<b>Microprocessor</b>	<b>Microcontroller</b>
1)Microprocessor contains ALU,control unit,different register and interrupt circuit	1)Microcontroller contains microprocessor,memory,I/O interfacing circuit and peripheral devices
2)It has many instructions to move data between memory and CPU	2) It has one or two instructions to move data between memory and CPU
3) It has one or two bit handling instructions	3) It has many bit handling instructions
4)Access times for memory and I/O devices are more	4) Less access time for built-in memory and I/O Devices
5) Microprocessor based system requires more hardware	Microcontroller based system requires less hardware
6) Microprocessor based system is more flexible in design point of view	6) Less flexible in design point of view
7)It has single memory map for data and code	7)It has separate memory map for data and code
8)Less number of pins are multifunctioned	8) More number of pins are multifunctioned

**Q6)a) Explain the Application of Microcontroller in Piezoelectric Actuator Drive** [7]

**Answer) Microcontrollers for piezo-electric actuator applications:-**

Microcontrollers provide powerful digital signal processing capability with reduced size and cost, allowing embedded applications to be targeted. The new UC45 board uses a microcontroller to provide fully-digital control of piezo-actuators at 10KHz. It features ADC and DAC with 16-bit resolution, for applications where high resolution is required, such as ultraprecise positioning. The UC45 aims to replace the SC75 analogous controller for traditional actuator control; it has the same size and is pin-to-pin equivalent. This means that it can be mounted directly inside drivers for piezo-actuators. It includes a digital PID controller followed by a digital filtering cell. The type of output filtering cell can be changed, notch of order 2, notch of order 4, low-pass of order 2, or a double notch of order 2 for multimode controlling. Simply connect the UC45 to the USB port of a computer, and all the control parameters can be modified online using an easy labview interface. Once the parameters are set, it can be disconnected from the computer and it will run autonomously, keeping the control parameters even after reboot. Due to the multi-channel ADC and DAC converters, multi-channel control is possible, and up to three control channels are available. Because it is digitally processed, the UC45 can be adapted to a broad range of other control situations without hardware modifications. Thus, it can be adapted to specific actuators requiring a particular control scheme or a hybrid controller, such as the Stepping Piezo Actuator (SPA). Due to numerical control, this new linear piezoelectric motor is able of nano positioning on a several-milimeters stroke.

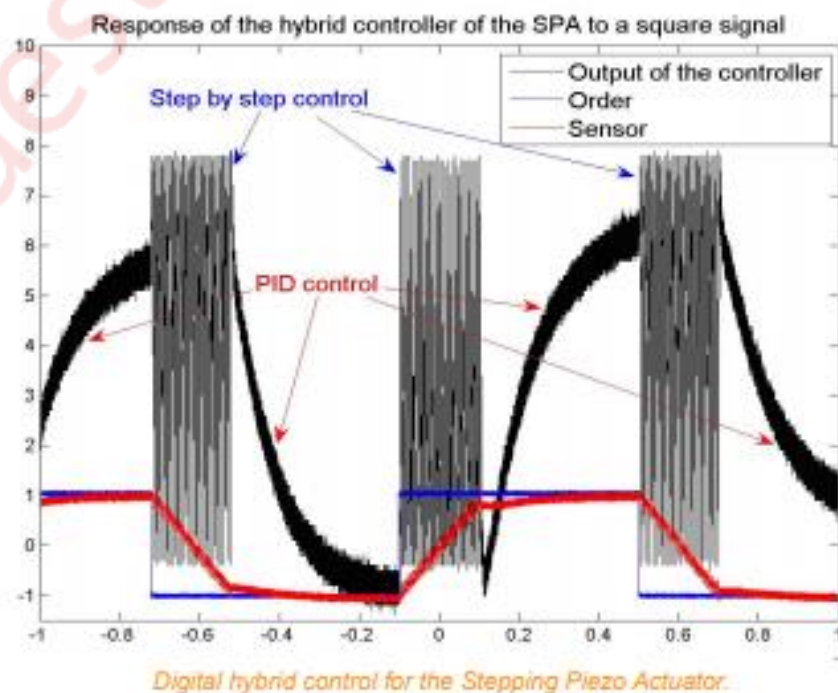



b) Explain any 1 method for the speed control of AC Induction Motors [7]

Answer) Cascade Control:-

In this method of speed control, two motors are used. Both are mounted on a same shaft so that both run at same speed. One motor is fed from a 3 phase supply and the other motor is fed from the induced emf in first motor via slip-rings. The arrangement is as shown in following figure.

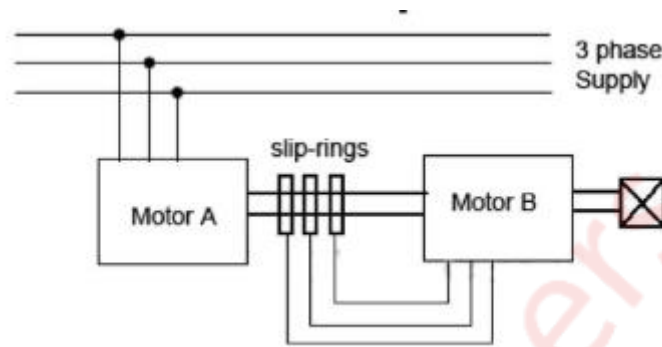

**Figure:-Cascade Control**

Motor A is called the main motor and motor B is called the auxiliary motor.

Let,  $N_{s1}$  = frequency of motor A

$N_{s2}$  = frequency of motor B

$P_1$  = number of poles stator of motor A

$P_2$  = number of stator poles of motor B

$N$  = speed of the set and same for both motors

$f$  = frequency of the supply

Now, slip of motor A,  $S_1 = (N_{s1} - N) / N_{s1}$ .

frequency of the rotor induced emf in motor A,  $f_1 = S_1 f$

Now, auxiliary motor B is supplied with the rotor induce emf

therefore,  $N_{s2} = (120f_1) / P_2 = (120S_1 f) / P_2$ .

now putting the value of  $S_1 = (N_{s1} - N) / N_{s1}$

$$N_{s2} = \frac{120f(N_{s1} - N)}{P_2 N_{s1}}$$

At no load, speed of the auxiliary rotor is almost same as its synchronous speed.

i.e.  $N = N_{s2}$ .

from the above equations, it can be obtained that,

$$N = \frac{120f}{P_1 + P_2}$$

With this method, four different speeds can be obtained,

1. when only motor A works, corresponding speed =  $N_{s1} = 120f / P_1$
2. when only motor B works, corresponding speed =  $N_{s2} = 120f / P_2$
3. If commulative cascading is done, speed of the set =  $N = 120f / (P_1 + P_2)$
4. If differential cascading is done, speed of the set =  $N = 120f / (P_1 - P_2)$

c) Write a short note on Multiplexer and Demultiplexer

[6]

Answer) Multiplexer:-

In digital systems, many times it is necessary to select single data line from several data-input lines, and the data from the selected data line should be available on the output. The digital circuit which does this task is a multiplexer.

It is a digital switch. It allows digital information from several sources to be routed onto a single output line, as shown in the Fig. The basic multiplexer has several data-input lines and a single output line. The selection of a particular input line is controlled by a set of selection lines. Since multiplexer selects one of the input and routes it to output, it is also known as data selector. Normally, there are  $2^n$  input lines and  $n$  selection lines whose bit combinations determine which input is selected. Therefore, multiplexer is '**many into one**' and it provides the digital equivalent of an analog selector switch.

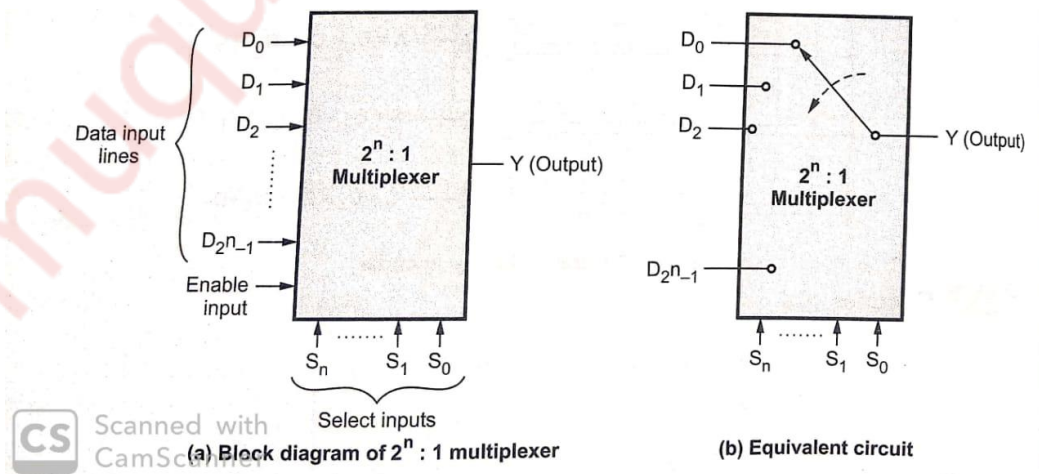

## Types of Multiplexer:-

- 2-1 multiplexer ( 1select line)
- 4-1 multiplexer (2 select lines)
- 8-1 multiplexer(3 select lines)
- 16-1 multiplexer (4 select lines)

**Demultiplexer:-** The data distributor, known more commonly as a **Demultiplexer** or **Demux** for short, is the exact opposite of the Multiplexer. The demultiplexer takes one single input data line and then switches it to any one of a number of individual output lines one at a time. The demultiplexer converts a serial data signal at the input to a parallel data at its output lines.

Demultiplexer is used to connect a single source to multiple destinations. The main application area of demultiplexer is communication system where multiplexer are used. Demultiplexing is the process of converting a signal containing multiple analog or digital signals backs into the original and separate signals. A demultiplexer of  $2^n$  outputs has  $n$  select lines.

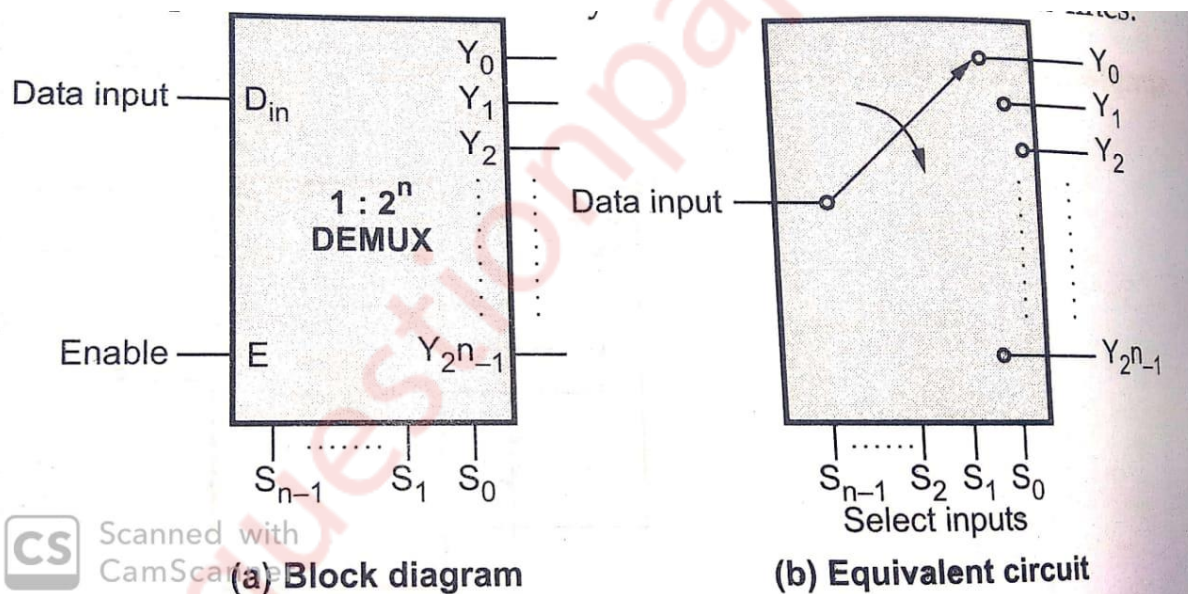

## Types of Demultiplexer:-

- 1 to 2 Demultiplexer ( 1select line)
- 1 to 4 Demultiplexer (2 select lines)
- 1 to 8 Demultiplexer (3 select lines)
- 1 to 16 Demultiplexer (4 select lines)