

## PRODUCTION PROCESS – I

SEM-III (NOV 2018)

### Q1. Write a short note on any four of the following

a. Compare brazing and soldering.

[5]

Answer

Brazing	Soldering
1. Filler metal has the melting point above 400°C.	1. Filler metal has the melting point below 400°C
2. More stable joints can be made.	2. Less stable joints can be made.
3. High pressure and temperature do not affect the joint.	3. Joints are affected by high temperature and pressure.
4. Equipment cost is more.	4. Equipment cost is very low.
5. Brazing is stated as when a filler metal or alloy is heated to its melting temperature above 450 °C.	5. Soldering is stated as the joining of metals using a filler material of a lower melting point than that of the parent metals to be joined.

b. CO<sub>2</sub> Moulding

[5]

Answer

1. In this process carbon dioxide is used to harden the mould.
2. The mould is prepared by ramming clean sand mixed with sodium silicate around the pattern.
3. Carbon dioxide gas is then fed into the mould which hardens the mould immediately.
4. The process can be easily used for all sizes of casting and can also be mechanized.
5. Dextrin, coal powder, wood flour and sea coal may be added to improve collapsibility.
6. The strength of the mould increases as the fineness of sand increases upto 80 mesh but decreases afterwards.
7. Since very high compressive strengths are reached in carbon dioxide moulding, problem of collapsibility may sometimes be faced.
8. Carbon dioxide moulding results in high accuracy and good surface finish. There is no need to harden the mould thus considerably reducing the manual work and cost.

### c. Thread Rolling

[5]

#### Answers

1. Thread rolling produces external threads by a cold forging operation rather than a cutting operation.
2. This is achieved by subjecting a thread blank to pressure between two hardened steel dies.
3. The surfaces of the dies carry reverse form of the thread to be cut.
4. The diameter of the blank is approximate equal to the pitch diameter of the required thread.
5. Application of pressure causes plastic flow of the material.
6. The die thread penetrates to form the depression or roots of the thread while the displaced material forms the crests and flanks.
7. The dies may be in the form of grooved blocks or threaded rolls.
8. Thread rolling can be carried out on any material that can withstand the forging pressure.
9. The method is generally used for small diameter workpieces and small pitches.

### d. Explosive welding

[5]

#### Answer

- Diagram-

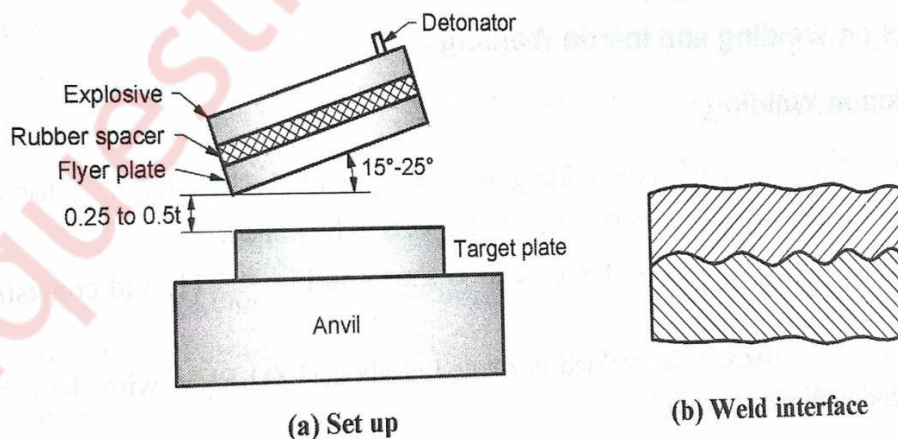

- Explanation –

- 1) In explosive welding detonation of an explosive is used to join two plates face to face.

- 2) The target plate is held fixed on an anvil as shown in figure. and other plate called flyer plate.
- 3) The minimum distance between the two plates is of the order of  $0.25 t$  to  $0.5 t$
- 4) where  $t$  is the thickness of the flyer plate and the angle between the plates can vary upto 25.
- 5) An explosive charge is kept on the top of the flyer plate with rubber spacers plate and the explosive.
- 6) When the explosive is detonated the flyer plate moves towards the target plate at a fast rate.
- 7) The nature of weld interface depends on the velocity of surface collision .
- 8) This type of welds have better mechanical properties .
- 9) It increases strength and hardness but decrease ductility.

#### e. Lapping and honing

[5]

##### Answer-

- **Lapping –**

1. It is an abrading process that is used to produce geometrically true surfaces, correct minor surface imperfections, improve dimensional accuracy, or provide a very close fit between two contact surfaces.
2. Very thin layers of metal are removed in lapping .
3. .It is low efficiency process and is used only when specified accuracy and surface finish cannot be obtained by other methods.
4. .Laps may be operated by hand or machine, the motion being rotary or reciprocating for lapping .
5. .Small flat surfaces may be lapped by holding the work against a rotating disc, or the work may be moved by hand in an irregular path over a stationary faceplate.

- **Honing-**

1. It is grinding or an abrading process mostly for finishing round holes by means of bonded abrasive stones, called hones.
2. Honing is therefore a cutting operation and has been used to remove as much as 3mm of stock but is normally confined to amounts less than 0.25mm.
3. Honing stones are made from common abrasive and bonding materials. This method is mostly used for finishing automobile crankshaft journals.
4. 4. When honing is done manually the tool is rotated, and the work piece is passed back and forth over the tool.
5. For precision honing, the tool is given a slow reciprocating motion as it rotates. It is done on general purpose machines, such as the lathe, drill press, and portable drills, as an expedient.

## Question - 2

**Q2 a ) With a neat sketch explain the principle and working of thermit welding. Also discuss its advantages, limitations and application.**

[8]

**Answer –**

- **Diagram –**

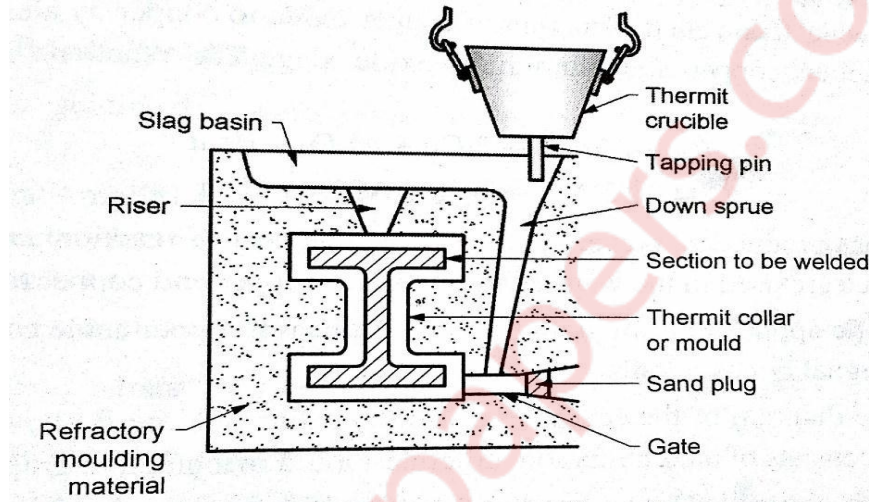

- **Principle Of Working -**

The working principle of thermit welding process is a thermite material which is a composition of a metal oxide, aluminium and fuel is used to achieve exothermic reaction. The heat generated melts the elemental metal ( Fe) and then this molten metal poured into the mold to join the two metal pieces together.

- **Working Of Thermit welding –**

1. Thermit welding is fusion welding process that makes use of intense heat produced when a mixture containing iron oxide and powdered aluminium is ignited.
2. The reaction is based on the high affinity of aluminium for oxygen
3. It reduces iron oxide to thermit steel and slag according to the equation -

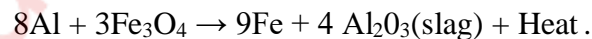

4. The superheated molten metal is poured at the desired place and on solidification forms the welded joint. The process is thus essentially a combination of casting and welding processes .
5. The thermit mixture consists primarily of finely divided aluminium and iron oxide in the ratio of about 1: 3 by weight.

6. Other metal oxides that can be used in place of iron oxide include oxides of copper, nickel, chromium or manganese but iron oxide thermit is the most commonly used.
7. The mixture is filled in specially designed refractory crucible and the reaction is started by igniting the mixture with a highly inflammable powder called starting thermit consisting primarily of barium peroxide.
8. When the starting thermit is ignited, an ignition temperature of about 1150°C is attained which initiates the main thermit reaction given above.
9. The reaction is self sustaining and very rapid as it is exothermic.
10. A temperature of the order of 3000 C is produced resulting in super heated thermit steel Slag being very light floats over the thermit steel thereby protecting the metal from atmospheric gases.
11. Apart from the basic ingredients of the thermit mixture other materials may be added to produce a desired thermit melt for any specific application.

- **Advantages –**

1. It is simple and easy process.
2. Low setup cost.
3. Metal joining rate is high.
4. Thermit welding can be done at site where casting is impossible.
5. This can be used where power supply is not available.

- **Disadvantage –**

1. It is used for limited metals like iron and copper.
2. It is uneconomical for welding light parts.
3. Highly depends on environmental condition like moisture contain, work piece alignment etc.

- **Applications -**

1. It is mostly used to weld railroad at the site.
2. It was used to weld thick plate before introduce electrosag welding.
3. They are used to repair heavy castings.
4. It is used to weld cable connectors of copper.
5. It is used to make structure joints in large ships etc.
6. It is used to joint pipe, thick plate etc. where power supply is not available.

**Q 2 b) Differentiate between open loop and closed loop system.**

**[6]**

**Answer –**

<b>Open loop system</b>	<b>Closed loop system</b>
1. It is easier to build.	1. It is difficult to build,
2. If calibration is good, they perform a. accurately	2. They are accurate because of feedback
3. Open loop systems are generally more stable.	3. These are less stable.
4. Optimization is not possible	4. Optimization is possible
5. They are not reliable	5. They are reliable
6. Not using feedback	6. Feedback using
7. Less accurate	7. More accurate
8. Simple in construction	8. Complicated in construction
9. Optimization in control is not possible	9. Optimization in control is possible
10. Easy maintenance & cost is less	10. Difficult to maintain & cost is more

**Q 2 C) . Explain the types of flames used in gas welding**

**[6]**

**Answer –**

Gas welding is fusion welding process in which fusion is obtained by completely melting the joint.

- The flames used in gas welding are as follows:

1. Balanced or neutral flame
2. Reducing or carburizing flame
3. Oxidizing flame

1) **Balanced or neutral flame-**

- **Diagram –**

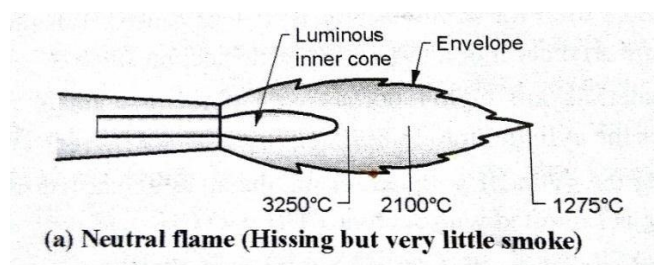

- **Explanation –**

1. The balanced or neutral flame is produced by burning approximately equal volumes of oxygen and acetylene at the tip of the torch nozzle.
2. This flame is characterized by a well defined luminous cone gradually rounding off towards the tip.
3. This luminous cone is surrounded by a bluish envelope or streamer.
4. The envelope is neutral in nature and provides a protective atmosphere around weld
5. The neutral flame is the most generally used flame for all heating and welding applications.
6. The flame makes a hissing sound but has very little smoke.

## 2) Reducing or carburizing flame

- **Diagram –**

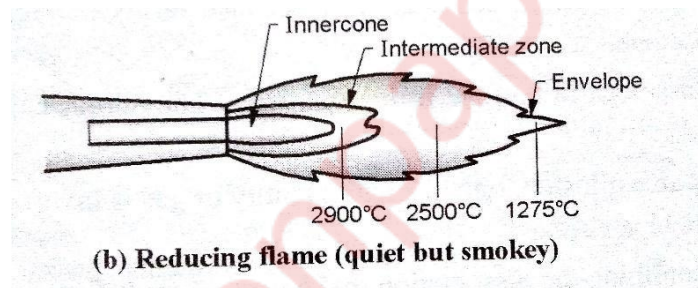

- **Explanation –**

1. This type of flame is obtained by burning an excess amount of acetylene. (oxygen to acetylene ratio - 0.85 to 0.95)
2. It is characterized by a secondary luminous intermediate zone surrounding the inner cone.
3. The rate of oxidation in this flame is slowed down and more acetylene burns atmospheric oxygen making the flame grow in size.
4. The luminous cone is not so well defined as in the balanced flame.
5. The excess acetylene zone is not clearly demarcated from outside envelope
6. The envelope takes on a reddish tinge and may carry some soot.
7. The intermediate zone contains free carbon monoxide and hydrogen.
8. It is reducing as well as carburizing in nature.

3) **Oxidizing flame –**

• **Diagram –**

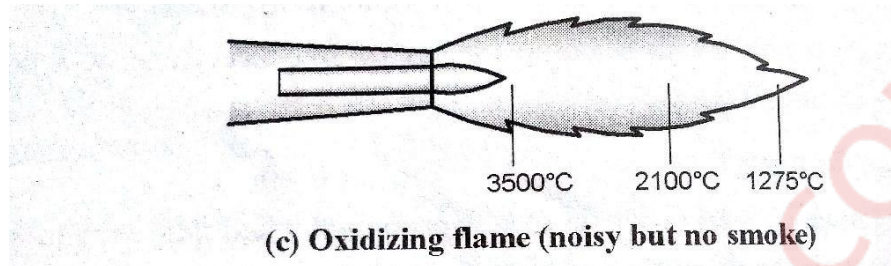

• **Explanation –**

1. The oxidizing flame is produced by burning acetylene with excess oxygen. (Oxygen to acetylene ratio - 1.15 to 1.5)
2. The inner cone becomes short and pointed
3. The envelope also is shortened due to intense oxidation.
4. The envelope is blue and the inner cone has reduced luminosity.
5. The oxidizing flame produces a hissing sound which becomes louder with increase in the proportion of oxygen.
6. The intermediate zone which carries the products of primary reaction contains some free oxygen from the torch.
7. It may also contain some carbon dioxide produced from the burning of carbon monoxide and is oxidizing in nature.

**Question 3**

**Q3 A ) Describe desired properties of pattern materials .**

**[8]**

**Answer –**

**Pattern:** It is the replica of the casting to be produced. Replica means, the shape of the pattern remains the same as that of the shape of the casting to be produced.

**Any material to be used for pattern making should have the following properties :**

1. Easy to work, shape and join.
2. Strong, hard and durable so as to be resistant to wear
3. Light in weight.
4. Dimensionally stable.
5. Cheap and easily available.



6. Resistant to corrosion and chemical action.
7. Able to take good finish
8. No moisture absorption by the pattern material would take place.
9. Surface finish produced on the pattern material must be good or excellent.
10. The material should be of low density.
11. Easiness in fabrication.
12. It should be cheaper (Pattern Cost).

The different types of pattern materials used in the casting process are as follows.

**1 Wood** -Except for moisture absorption, the wood is possessing all other properties which are required as a pattern material and out of all the different woods, the wood which is absorbing less moisture will be used as pattern material. **Example:** Teak wood, Mohagaoni, etc.

**2. Metal-** In the case of metal patterns, the density is high and it is difficult to manufacture the metal patterns. **Ex:** Aluminium, white metal, Titanium has low density, but they are of very costly.

**3. Plastic** -They are possessing all the properties which are required for pattern material.hence in today's manufacturing industry, plastics are the most commonly used pattern materials.  
**Ex:** Epoxy resin, PVC, Nylon, Cellulose, Polystyrene, etc.

**4. Wax pattern-** It will be selected as a pattern material for producing the complex shape of the pattern, to produce the Complex shape of the casting i.e. because of the highest softness of the wax material, it is possible to produce the Complex shape of the pattern easily.**Ex.** handicrafts.

## 5. Plaster

1. Plaster of paris or gypsum cement is also used for making patterns and core boxes.
2. Plaster is easy to cast and work with but is brittle and is not suitable when the number of castings to be produced is large.
3. Plaster patterns can be prepared by pouring the plaster slurry in a mould prepared with the help of a master pattern.
4. Alternatively, the pattern may be made by sweeping it into the desired shape with suitable tools.
5. An advantage of plaster as a pattern material is that plaster expands on solidification.

**Q3 b) Describe machining operations performed on lathe machine.**

**[6]**

**Answer –** Operations Commonly performed on a lathe include turning, facing, parting, turning, grooving, drilling, boring, knurking, chamfering, eccentric turning button boring, taper turning and thread cutting. When supplied with suitable attachments the lathe may also be used for milling

**1. Turning:**

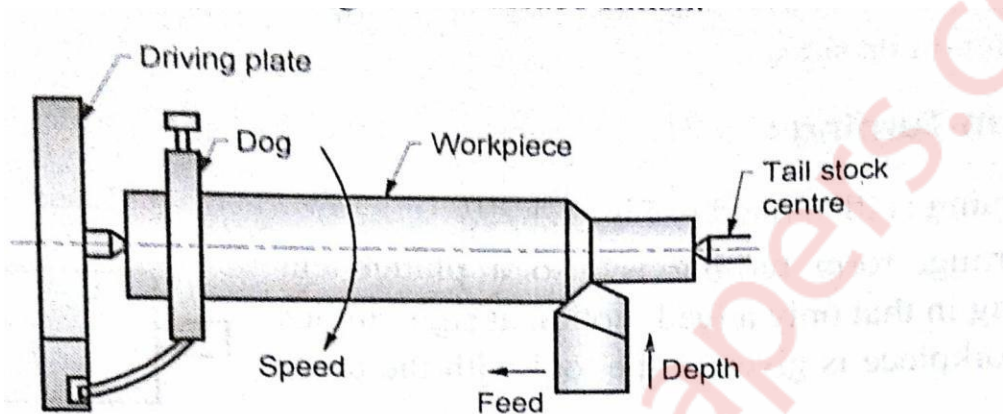

1. Turning is the operation in which a cylindrical surface is produced by generating as shown in Figure
2. The workpiece is supported between centres or in any other work holding device and rotated at the desired speed.
3. The tool is first given a depth of cut by using the cross slide motion of the carriage and axial feed by hand or power
4. The simultaneous motion of the workpiece and the tool result in a helical cut repeated cuts may be necessary to obtain a desired reduction of size.

**2. Facing**

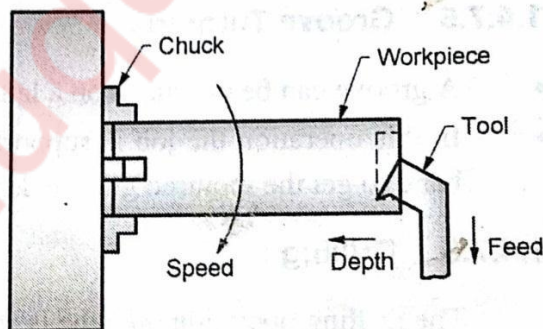

1. Facing is an operation used to produce a flat surface at right angles to the rotational axis of the job
2. In this case tool is fed at right angle to the job while the depth of cut is provided by the axial motion of the carriage.
3. The job may be held in a chuck as shown or between centres.
4. A half centre is sometimes used when facing the job held between centre While facing, a tool may be fed inwards towards the centre or outwards. The latter method is more common.

### 3. Parting:

1. Parting or cutting off is the operation of severing or cutting away a desired length of bar
2. It is done with a narrow cutting tool which is cuts only on the edge Cross feed is given to the tool by hand. The job is held in a chuck but an additional support may be provided at the free end with the dead centre.

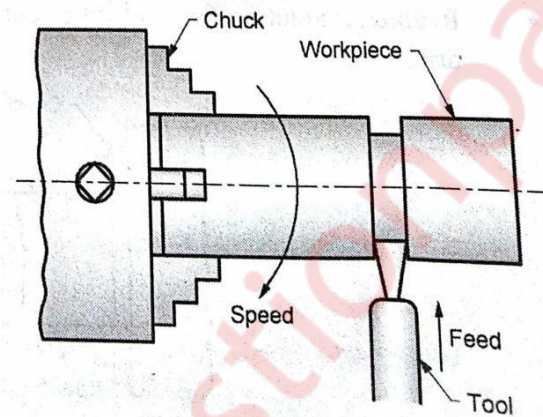

### 4. Form Turning

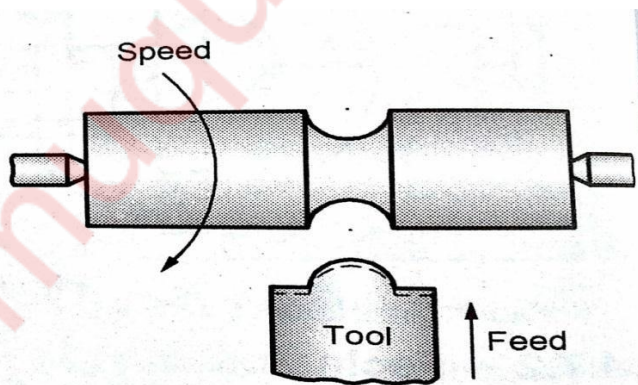

1. Like parting, form turning is also a plunge cutmachining in that only a feed motion at right anglesto the workpiece is given to the tool with the cross slide.
2. It is important that the cutting edge must be adjusted to the correct centre height otherwise a contour different from the tool contour will be produced on the workpiece.

### 5. Drilling:

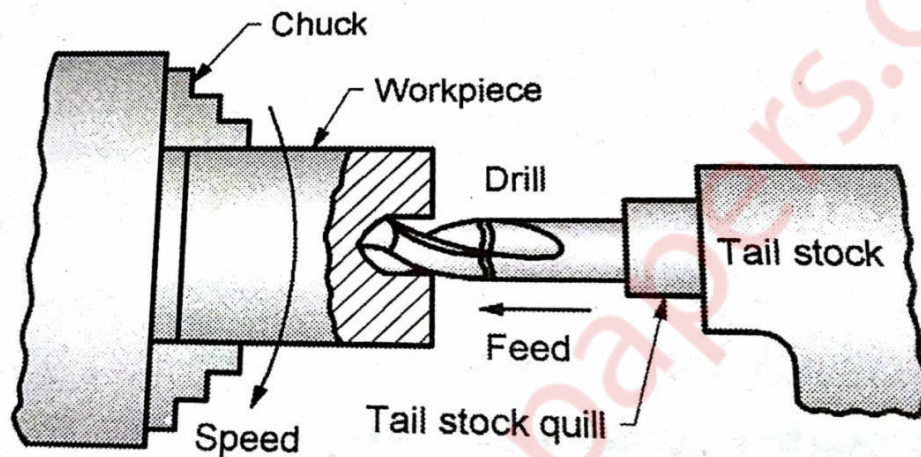

1. The drilling operation on lathe is shown in Figure
2. The workpiece is held in a chuck or on a face plate and the drill is held in the tailstock quill or in the drill chuck held in the quill.
3. The taper in the quill ensure that the axis of the drill is concentric with the rotational axis of the spindle.
4. Feeding is done by movement of the tail stock quill.
5. Reamers, counterbores and other cutting tools may also be used similarly in place of drill

### 6. Knurlin

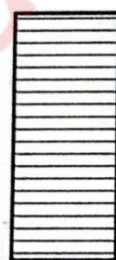

**Straight**

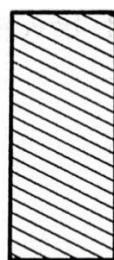

**Left handed**



**Right handed**



**Diamond**

1. Knurling is the process of providing rolled Impression on the cylindrical surface of workpiece
2. Knurling is done on the work piece so that it does no slip when held and operated by hand
3. The workpiece is supported in the chuck but since quite heavy forces are involved in the knurling process an additional support is generally provided at the free end with the tail stock centre.
4. Knurling is done with two serrated hardened steel rollers pressing into the workpiece as shown.

Knurling may be

1. Straight
2. Left handed
3. Right handed
4. Diamond type

### 7. Chamfering

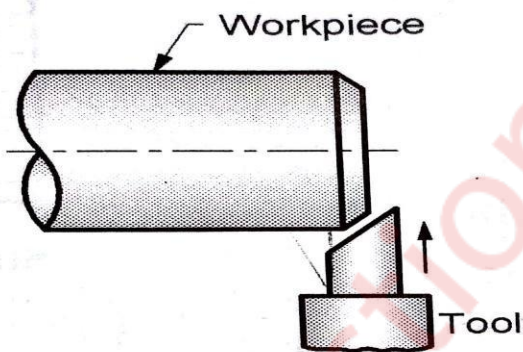

Chamfering is the process of bevelling the extreme end of a work piece. Chamfering is done with a form tool by giving feed to the tool at right angles to the lathe axis

Chamfering is done for

1. Giving a better appearance to the work piece.
2. Protecting the ends of the work piece.
3. Removing burrs etc.
4. Providing safety to workers from sharp cutting edges.

**Q3 c) What are automatic machines? write it's classification. [6m]**

**Answer-**

### **Automatic Machine**

- Automatic Machine Or simply automats are machines In which the series of operations on Work Piece Are Done Automatically Without The Attention Of An Operator.
- All movements of cutting tools, their sequence of application, raw material feeding, parting off and unloading of finished work piece are all done by the machine itself.
- The purpose of the operator is to only set the sequence of machining operations and in some cases alignment of tools is also done by the operator. Apart from this calibration of tools is also done by the operator
- The automatic machine performs the entire set of operations in proper sequence and produces the desired product in desired quantities.
- In automats the operating cycles are automated by a definite control system like mechanical, electrical, hydraulic or pneumatic or a combination of those systems.

### **Automats / Automatic machines classification :**

#### 1) Classification according to the type of stock material used

- Bar stock machine :
- Chucking machine:

#### 2) Classification according to the number of spindles

- Single spindle automats:
- Multi spindle automats:

#### 3) Classification according of the direction axis of machine spindles

- Horizontal spindle type:
- Vertical spindle type:

#### 4) Classification according to the feed control

- Single cam shaft rotating at constant speed
- Single cam shaft with two speeds
- Two cam shaft

5) Classification according to the use

- Single purpose machine
- General purpose machine

**Advantages of Automats**

1. Mass Production of identical parts.
2. High Accuracy is Maintained
3. Time of Production is minimized
4. The Bar stock is fed automatically.

**Question 4**

**Q4 a) Describe the classification ,selection procedure and application of drilling machine**

**[8]**

**Answer-**

**Drill Machine**

Drill is a machine tool used for drilling the holes in solid materials like metal and wood with drill bit or driver bit. Drills are used in wide range of applications in metalworking, constructions and woodworking industries. The small drill is used for our household requirements to make holes on wall and materials. These are available in various sizes and power capacities. Drill is one of the oldest handy tools used from very beginning of the industrial era.

**Drilling machines or drill presses can be classified in following categories :**

1. Sensitive drilling machine
2. Radial drill press
3. Turret drill press
4. Portable drilling machine
5. Vertical drill press
6. Gang drill press
7. Multi-spindle drill press

**1. Portable Drilling Machine**

1. This types of drilling machines are commonly used in all the workshop.
2. Used to drill small sized holes.

3. It is operated by holding in a hand. The workpiece where the hole is to be drilled is held in a vice.



## 2. Sensitive Drilling Machine

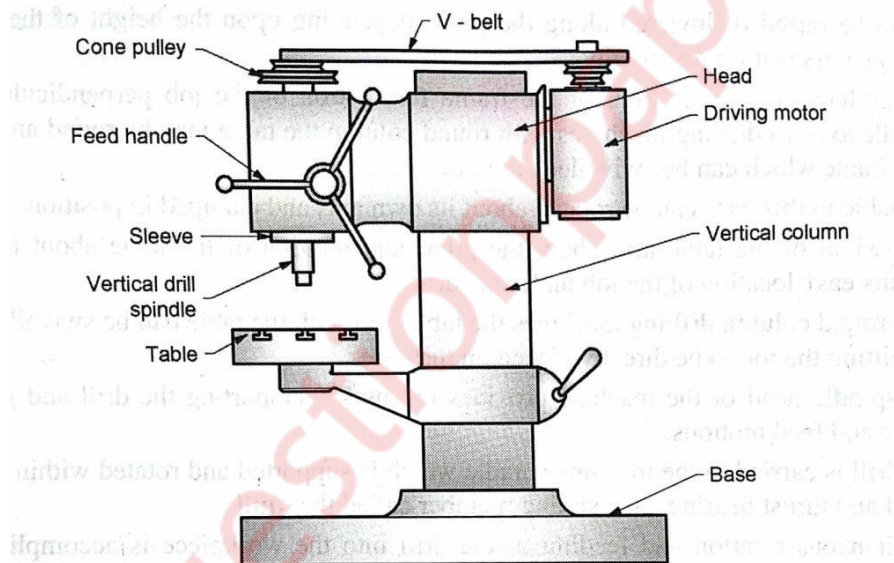

1. This types of drilling machine are used to drill small holes at high speeds in lighter jobs or workpieces.
2. The machine may be mounted on the bench or floor & the drilling work is started with the drill fed into the workpiece by purely hand control.
3. Hand feed permits the operator to sense the progress of the drill into the workpiece, so that if there is any drill worn out or jams it may be released immediately to prevent the drill bit from breaking.



4. Since the operator senses the cutting action at any instant it is called as the sensitive drilling machine. These machines are capable of drilling small holes of diameter as small as **0.35 mm to 15 mm**. These machines run at the higher speed as high as **2000 rpm**

### 3. Upright Drilling Machine / vertical drilling machine

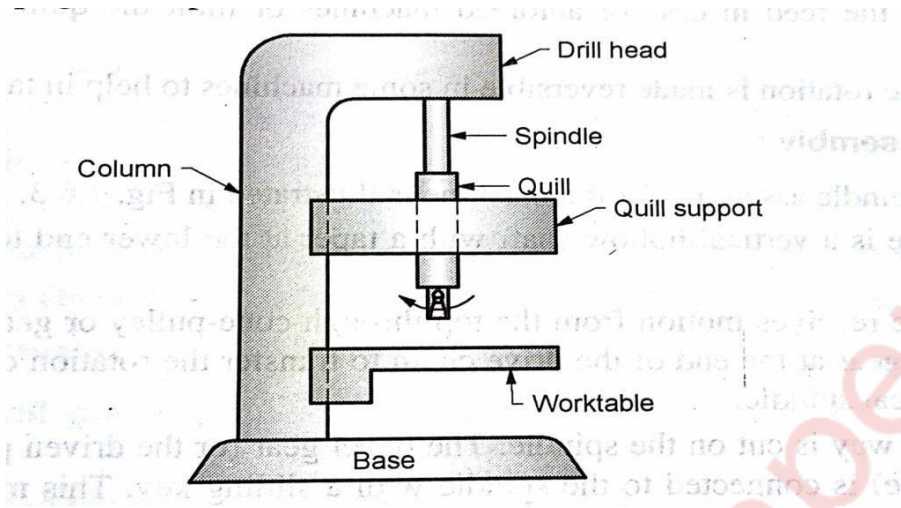

1. It is larger in size and stronger than **sensitive drilling machine**.
2. It is used for drilling medium and large sized holes.
3. Based on the type of column used it is classified as a round column and box column upright drilling machines

### 4. Radial Drilling Machine

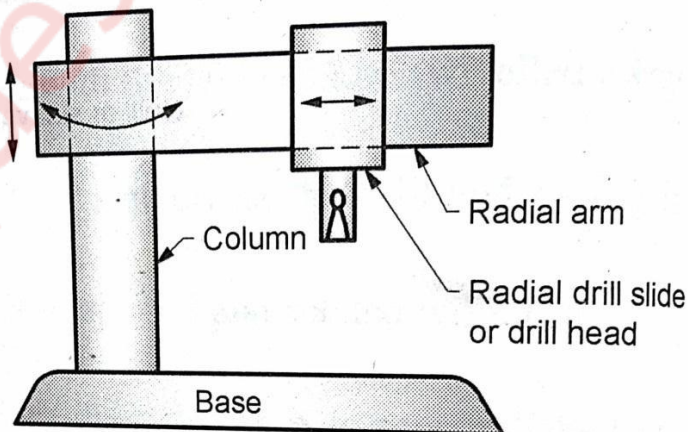

1. The schematic diagram of the **radial drilling machine** is shown in the figure
2. It consists of the base, column radial arm, drill head, spindle speed and feed mechanism.

### 5. Gang Drilling Machine

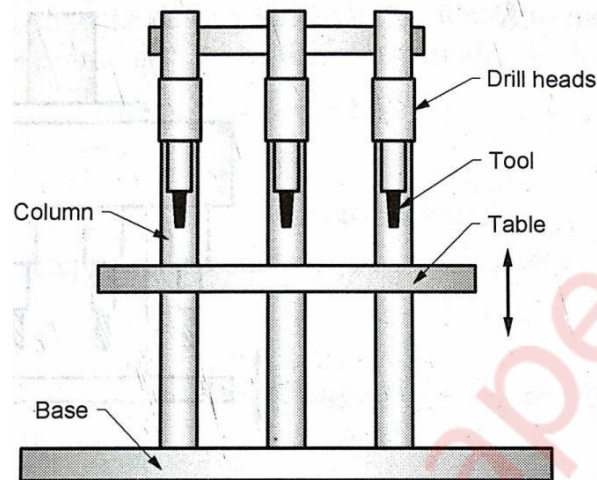

1. This machine consists of the number of drill heads placed side by side so that more than one hole of same or different sizes can be drilled at a time on the same job or on different jobs.
2. The space between drill spindles is varied to suit the gap between the holes. This type of machine tool is used to drill a large number of holes on the same job at a faster rate.
3. The main advantage of this type of machine tool is that the series of operation can be performed with different spindle mounted with different tool bits on the same workpiece by moving it from one position to another position

### 6. Multi Spindle Drilling Machine

1. This machine tool is similar to a gang drilling machine in construction.
2. It is used to drill the number of hole in the same workpiece simultaneously and to reproduce the same work in a number of similar jobs.
3. All the spindle are driven by the single motor and fed continuously. During the feeding table with the workpiece is raised or lowered and drill head position is not varied.

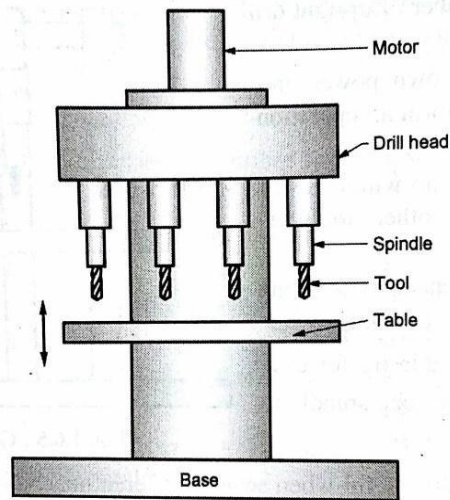

### Applications of Drill Machines

1. The basic function of drill machine is to create hole of different size in solid materials.
2. Different drills are used for industry specific applications. Drill rigs are used to drill water wells and oil wells.
3. Hand drills are used for screwing and fastening.
4. Electrical pistol grip drill is used in common masonry works by builders, electricians and plumbers.
5. Hammer drill is specifically used by carpenters to drill and fix the wooden parts.
6. Cordless drills are useful where electrical supply is not possible to get for drilling.
7. Pillar drill machine (also referred as drill press) is used in commercial applications where it required bulk production of drilled materials in various size and shape like metal sheets, plastic, wood, glass and concrete construction applications.
8. The induction based power supply is easily controlled in drill press to increase or decrease the drilling speed and capacity.
9. The capacity of drill press differs with pillar diameter, spindle nose, spindle travel, spindle speed and electronic motor used in the machine.
10. These are widely used in automobile, printing and engineering field to increase the durability and tensile strength of the machine with effective execution to the resistive materials with quality performance.
11. Milling cum drilling machine is broadly adopted in the industries where required mixing and grinding of solid and liquid substances.

Q4 b ) explain blow moulding process with sketch.

[6]

Answer

• **Diagram –**

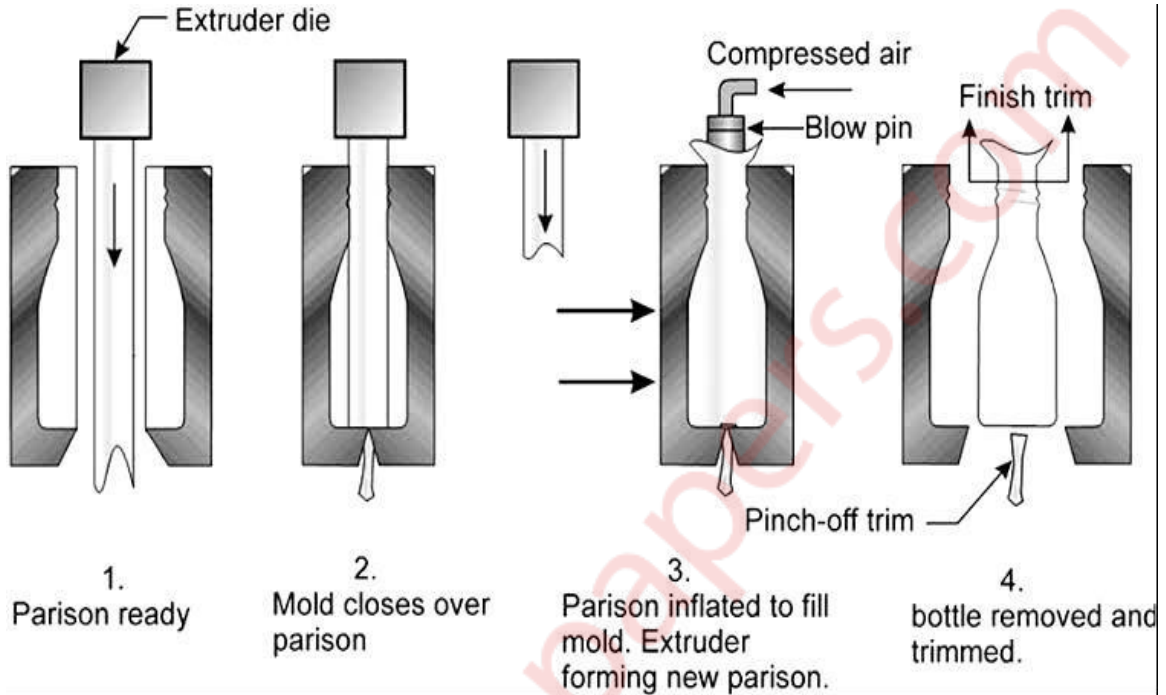

• **Explanation –**

1. Blow moulding is a moulding process in which air pressure is used to inflate soft plastic into a mold cavity.
2. It is an important industrial process for making one-piece hollow plastic parts with thin walls, such as bottles and similar containers.
3. Since many of these items are used for consumer beverages for mass markets, production is typically organized for very high quantities.
4. The technology is borrowed from the glass industry with which plastics compete in the disposable or recyclable bottle market.
5. Blow moulding is accomplished in two steps: (1) fabrication of a starting tube of molten plastic, called a parison (same as in glass-blowing); and (2) inflation of the tube to the desired final shape.

1) Forming the parison is accomplished by either of two processes:

1. extrusion moulding –

The sequence is automated and usually integrated with downstream operations such as bottle filling and labeling. It is usually a requirement that the blown container be rigid, and rigidity depends on wall thickness among other factors.

2. Injection molding-

Compared to its extrusion-based competitor, the injection blow-molding process has a lower production rate, which explains why it is less widely used.

**Q 4c ) Difference between pattern and core box.**

**[6]**

Characteristics	Pattern	Core box
1. Used for	Making the mould	Making the core
2. Purpose	To create cavity for molten metal	To make core
3. Types	Loose,gated,match plate,cope and drag ,shell	Half,dump,split,stickle,left and right hand , gang
4. Material	Wood,metal,plastic,plaster	Wood
5. Support	Core prints	Not needed
6. Defination	It is defined as replica of objects to be cast	Core box is tooling used to create the core

**Qustion 5**

**Q5 a ) Discuss the various defects found in rolled parts. .**

**[8]**

**Answer –**

The defects commonly observed in rolled products include the following:

**1 Folds**

Folds occur during plate rolling when the reduction per pass is very small.

## 2 Lamination

Small cracks appear when reduction in thickness is quite high.



## 3 Edge cracking

This defect is caused either due to low ductility of the work material or because of uneven deformation near the ends. Cracks are caused during cold rolling if the metal becomes too much work hardened. The cracks occurred on edge of hot roll coil due to excess amount of quenching effect.

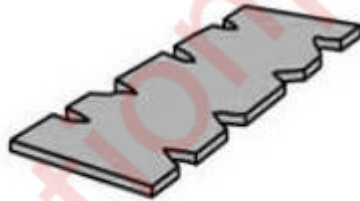

(c) edge cracks

## 4 Fins

Fins are formed on rolled bars when the metal forces itself in the space between the rolls. Fins can lead to folds, cracks etc.

## 5 Alligating:

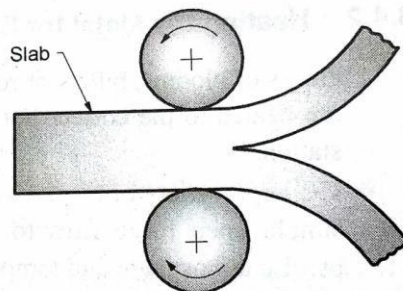

Alligatoring shown in Figure, splitting of the workpiece along a horizontal plane on the exit side. This defect occurs during slab rolling of aluminum alloys.

6. **Wavy edge** - The roll part consists of middle position bend or deflection due to compressive load on work rolls resulting more thicker than end of work piece.

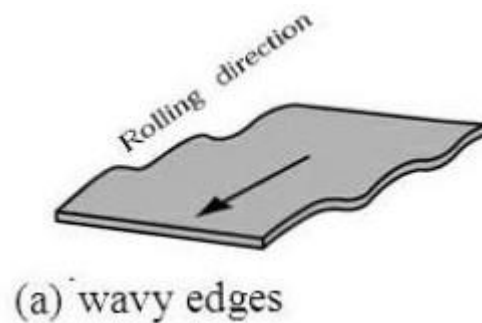

**Q5b ) Define weldability and describe factors affecting on it.**

[6]

**Answer**

- **Weldability** is the ability of any material (usually metals and its alloys) to weld with similar materials. **Weldability** can also be defined as the capability of metal to be welded under the fabrication conditions imposed satisfactorily on the intended surface.
- **Factors affecting weldability** – Following factors that affects weldability.

1. **Melting point of metal:** Materials with a medium melting point can be welded very easily.
2. **Thermal conductivity:**

Material with high thermal conductivity (K) are treated as difficult to weld materials.

3. **Reactivity:**

If the material reacts with air, water or surroundings it becomes difficult to weld.

4. **The coefficient of thermal expansion of metals:**

Material with high thermal expansion coefficient, it becomes difficult to weld.

5. **Electrical resistance:** Higher the electrical resistance of the material, it becomes difficult because it requires a lot of heat energy

6. **Surface condition:**

The material with the dirty surface it becomes difficult to weld.

Q5 c) Differentiate between hot working and cold working.

[6]

Answer-

S.No.	Cold working	Hot working
1	It is done at a temperature below the recrystallization temperature.	Hot working is done at a temperature above recrystallization temperature.
2.	It is done below recrystallization temperature so it is accomplished by strain hardening.	Hardening due to plastic deformation is completely eliminated.
3.	Cold working decreases mechanical properties of metal like elongation, reduction of area and impact values.	It increases mechanical properties.
4.	Crystallization does not take place.	Crystallization takes place.
5.	Material is not uniform after this working.	Material is uniform thought.
6.	There is more risk of cracks.	There is less risk of cracks.
7.	Cold working increases ultimate tensile strength, yield point hardness and fatigue strength but decreases resistance to corrosion.	In hot working, ultimate tensile strength, yield point, corrosion resistance are unaffected.
8.	Internal and residual stresses are produced.	Internal and residual stresses are not produced.
9.	Cold working required more energy for plastic deformation.	It requires less energy for plastic deformation because at higher temperature metal become more ductile and soft.
10.	More stress is required.	Less stress required.
11.	It does not require pickling because no oxidation of metal takes place.	Heavy oxidation occurs during hot working so pickling is required to remove oxide.



Q6 a) With the help of neat sketch explain the gating system in casting process. . [8 ]

Answer –

- **Diagram –**

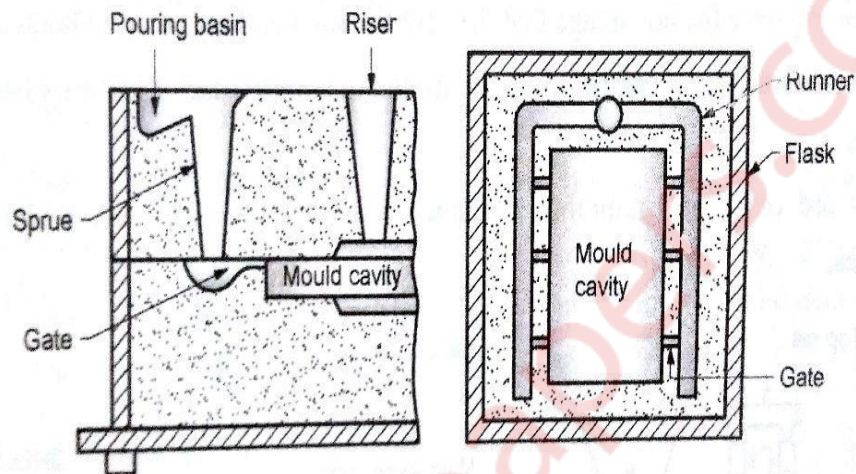

- **Explanation –**

1. The term gating system refers to all passageways through which the molten metal passes to enter the mould casting.
2. A typical gating system consists of a pouring basin a down gate or vertical passageway called sprue, ingate or gate through which the metal flows into the mould cavity and the riser.
3. In larger castings a runner may be used for distributing the metal to several gates around the cavity.
4. The design of the metal flow passages is closely associated with the design and placement of risers and chills.
5. A well designed gating may result in a bad casting if risers and/or chills are not properly designed and positioned.

- **Elements of gating system –**

1. **Pouring basin :**

- a. This is otherwise called as bush or cup. It is circular or rectangular in shape. It collects the molten metal, which is poured, from the ladle.

2. **Sprue :**

- a. It is circular in cross section. It leads the molten metal from the pouring basin to the sprue well.

3. **Sprue Well :**

- a. It changes the direction of flow of the molten metal to right angle and passes it to the runner.

4. **Runner :**

- a. The runner takes the molten metal from sprue to the casting. Ingate: This is the final stage where the molten metal moves from the runner to the mold cavity.

5. **Slag trap :**

- a. It filters the slag when the molten metal moves from the runner and ingate. It is also placed in the runner.

- **Functions of gating system**

1. To deliver liquid metal into mould.
2. It should introduce the molten metal with least turbulence.
3. It should help promote proper temperature gradient.
4. It should facilitate complete filling of the mould before solidification.

**Q6 b )Define the terms spread, elongation, draft, with respect to rolling.**

**[6]**

**Answer-**

- **Spread**

Absolute Spread is the change in width between the stock entering and leaving a stand.

Spread is dependent on several factors including

- draft.
- roll diameter,
- stock temperature,
- roll material,
- and material being rolled

For a given stock size and reduction, the bigger the roll diameter the greater the spread; the lower the temperature, the greater the spread.

- **Elongation**

Elongation is the increase in length of the stock due to the reduction in area. Elongation usually defines the total elongation from billet to product, or in a specific section of the mill,

**for example** the roughing mill or finishing block.

- **Draft**

- 1) Draft is the reduction in bar height in the pass. Absolute draft is expressed in linear units and is the difference between the entry height and exit height of the stock.
- 2) Relative draft is the reduction in height expressed as a percentage of the entry height

**Q6 c) Compare thermoplastics and thermosetting plastics.**

**[6]**

**Answer –**

<b>Thermoplastic polymers</b>	<b>Thermosetting polymers</b>
<b>1.</b> These are formed by addition polymerisation	<b>1.</b> These are formed by condensation polymerization
<b>2.</b> Monomer used in these is generally bifunctional	<b>2.</b> In this monomer used is tri, tetra or polyfunctional
<b>3.</b> They are long chain linear polymer with negligible cross links	<b>3.</b> These have three- dimensional network structure with number of cross links
<b>4.</b> They have low molecular wt.	<b>4.</b> They have high molecular wt
<b>5.</b> They are soft, weak , brittle	<b>5.</b> They,are hard, strong and more brittle
<b>6.</b> They can be softened and reshaped and reused.	<b>6.</b> They cannot be softened and reshaped again once again.
<b>7.</b> e.g.- polyethylene, polystyrene, PVC, PVA etc.	<b>7.</b> e.g.- phenol formaldehyde, ureaformaldehyde, nylon 6:6 etc.