

MUMBAI UNIVERSITY

Principles Of Communication Engineering

SEMESTER 4 - MAY 2019 – Choice Based

Q.1 Solve the following.

a) Why AGC is required in radio receiver?

[5M]

Ans : i) AGC is a departure from linearity in AM radio receivers.

ii) The AGC circuit keeps the receiver's output level from fluctuating too much by detecting the overall strength of the signal and automatically adjusting the gain of the receiver to maintain the output level within an acceptable range

iii) In simple AGC is a system which will change the overall gain of the receiver automatically, this is done in order to keep the receiver output constant even when the signal strength at the input of the receiver is changing.

iv) In AGC system a dc voltage (AGC bias) is derived from the detector. This AGC bias is thus proportional to the strength of received signal.

v) AGC bias is applied to a selected number of RF and IF amplifiers and mixer stage.

vi) The transconductance and hence the gain of the devices connected in these stages is dependent on the applied AGC bias.

b) Explain Noise figure and noise factor.

[5M]

Ans : i) Noise figure (NF) and noise factor (F) are measures of degradation of the signal-to-noise ratio (SNR), caused by components in a signal chain.

ii) It is a number by which the performance of an amplifier or a radio receiver can be specified, with lower values indicating better performance.

ii) The noise factor is defined as the ratio of the output noise power of a device to the portion thereof attributable to thermal noise in the input termination at standard noise temperature T_0 (usually 290 K).

iv) The noise factor is thus the ratio of actual output noise to that which would remain if the device itself did not introduce noise, or the ratio of input SNR to output SNR.

v) Formulas :

$$\text{Noise Factor} = \frac{(S/N)_{in}}{(S/N)_{out}} \quad \& \quad \text{Noise Figure} = 10 \log(\text{Noise Factor})$$

c) Why IF is selected as 455kHz in AM?

[5M]

Ans : i) A typical AM range or tuning range is between 540 to 1650 kHz. IF cannot be selected between this tuning range as this will cause instability and heterodyne whistles are heard at output side.

ii) If IF selected value is high then reneutralization of IF amplifier becomes difficult and stability becomes low,

iii) If IF selected value is low then selectivity becomes too sharp which causes attenuation of sidebands of desired signal leading to poor fidelity.

iv) With low IF value image frequency rejection ratio becomes poor which leads to double spotting.

v) Because of the above reason IF frequency is selected in between 430 to 460 kHz. And hence IF is selected as 455 kHz.

d) Explain natural top and flat top sampling. [5M]

Ans :

i) Natural Sampling is a practical method of sampling in which pulse have finite width equal to τ . Sampling is done in accordance with the carrier signal which is digital in nature.

ii) Natural sampling is similar to impulse sampling, except the impulse train is replaced by pulse train of period T . i.e. you multiply input signal $x(t)$ to pulse train $P(t-nT)$.

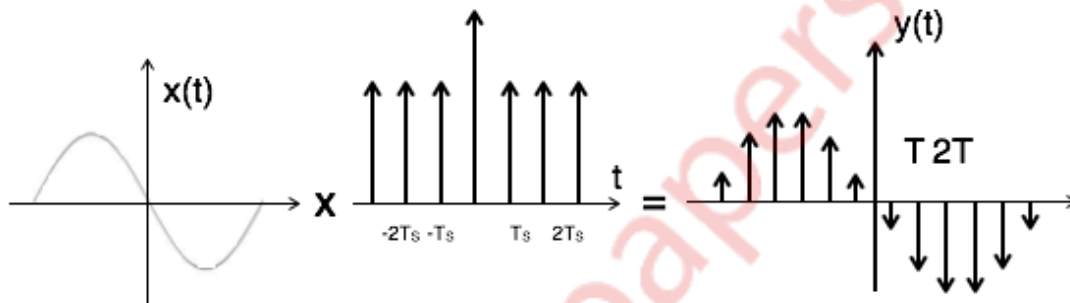

iii) Flat top sampling is like natural sampling i.e; practical in nature. In comparison to natural sampling flat top sampling can be easily obtained.

iv) In this sampling techniques, the top of the samples remains constant and is equal to the instantaneous value of the message signal $x(t)$ at the start of sampling process. Sample and hold circuit are used in this type of sampling.

v) During transmission, noise is introduced at top of the transmission pulse which can be easily removed if the pulse is in the form of flat top.

vi) Here, the top of the samples are flat i.e. they have constant amplitude. Hence, it is called as flat top sampling or practical sampling. Flat top sampling makes use of sample and hold circuit.

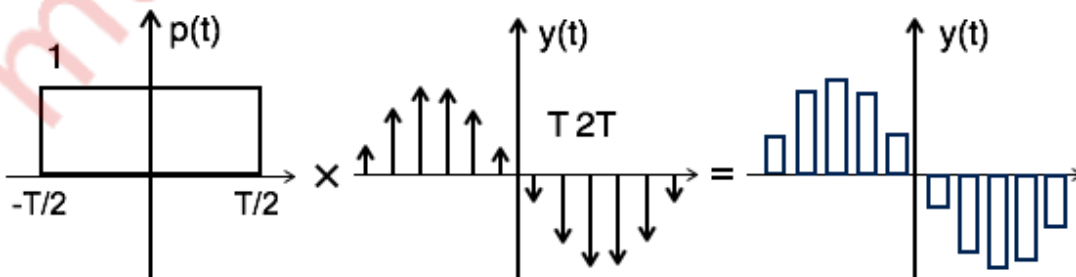

e) Compare narrow band FM and wideband FM.

[5M]

Ans :

Narrowband FM	Wideband FM
1.Modulation index is less than 1	1.Modulation is greater than 1.
2.Frequency Deviation = 5kHz	2. Frequency Deviation =75kHz
3.Modulating frequency = 3kHz	3. Modulating frequency = 30Hz to 15kHz
4.Suppression of noise is very less.	4.Noise is more suppressed.
5.Applications : FM mobile communication,short range ship to shore communication,etc	5.Applications: Entertainment broadcasting,high quality music transmission,etc

Q.2 a) List the methods used for SSB generation.Explain the third method of SSB

Generation with suitable diagram.

[10M]

Ans : i) In radio communications, single-sideband modulation (SSB) or single-sideband suppressed-carrier modulation (SSB-SC) is a type of modulation used to transmit information, such as an audio signal, by radio waves. A refinement of amplitude modulation, it uses transmitter power and bandwidth more efficiently.

ii)The methods employed for SSB generation are as follows:

a.Filter Method

b.Phase-Shift Method

c.Third Method

iii)Third method of SSB generation, like the phasing method, depends for its operation upon phase cancellation of two DSBSC-like signals. But,

1. it does not require wideband phasing networks, like the phasing method of SSB generation.

2. it does not require sharp cut-off filters, operating away from baseband, as does the filter method of SSB generation.

3. its unwanted components - those which are not fully removed (by phasing, as in the phasing method, or by imperfect filtering, as in the filter method) - do not cause interference to adjacent channels, since they fall inside the SSB channel itself

iii) There are two pairs of multipliers. These are referred to as quadrature multipliers, since they use 'carriers' phased relatively at 90 deg. This configuration is found in many communications circuits. The message bandwidth is defined as B Hz.

iv) It is shown as extending down to DC, but in practice (speech messages) this is not necessary - even undesirable.

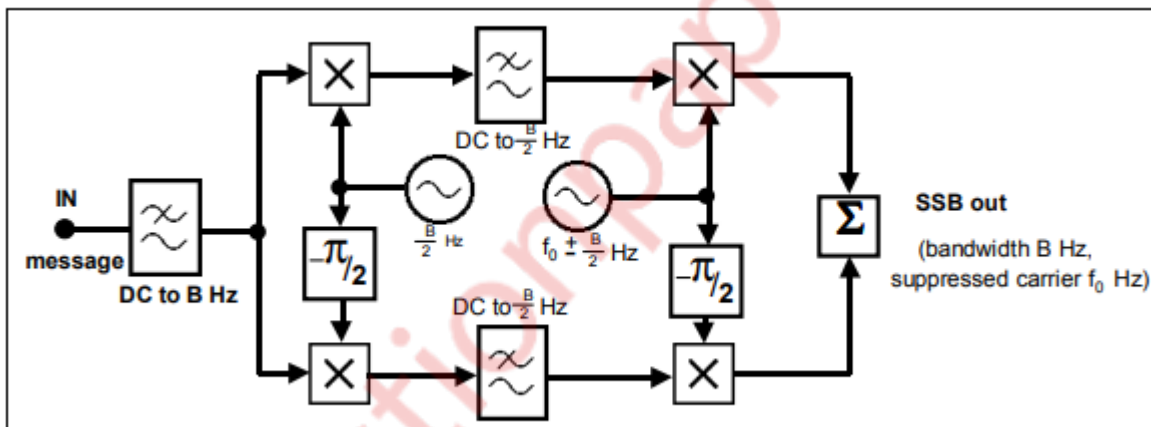

v) The DC requirement would introduce some complications, including the need for the first pair of quadrature multipliers to be DC coupled. Two filters are required, but they are at baseband, where design and realization is simplified. They must, however, be matched (amplitude and phase responses) as closely as possible. There are two phase shifters, but they are required to produce a 90 deg. phase shift at a single frequency only.

vi) From the block diagram, we see that the latter part of this circuit is identical to that of the phase-shift method, but the way in which appropriate voltages are fed to the last two balanced modulators at points C and F has been changed.

vii) Instead of trying to phase-shift the whole range of audio frequencies, this method combines them with an AF carrier f_0 , which is a fixed frequency in the middle of the audio band, 1650 Hz.

viii) A phase shift is then applied to this frequency only, and after the resulting voltages have been applied to the first pair of balanced modulators, the low-pass filters whose cut-off frequency is f_0 ensure that the input to the last pair of balanced modulators results in the proper eventual sideband suppression.

ix) It may be shown that all lower sideband signals will be cancelled for the configuration of the given Figure, regardless of whether audio frequencies are above or below f_0 .

x) If a lower sideband signal is required, the phase of the carrier voltage applied to M1 may be changed by 180° .

xi) Advantages:

--It has the advantages of the phase-shift method, such as its ability to generate SSB at any frequency.

--It uses low audio frequencies, without the associated disadvantage of an AF phase-shift network required to operate over a large range of audio frequencies.

xii) Disadvantages:

--The third method is in direct competition with the filter method, but is very complex.

--It is expensive and so cannot be used commercially.

b) The unmodulated carrier power of AM transmitter is 10KW and carrier frequency is 2MHz. The carrier is modulated to a depth of 50% by an audio signal of 5KHz. Assume $R=1\text{ohm}$.

i) Determine the total transmitted power.

ii) Determine the SSB power.

iii) Percentage of power saving if SSB is transmitted.

iv) Draw the frequency spectrum and find the bandwidth.

[10M]

Ans : Given : $P_c = 10\text{KW}$ $f_c = 2\text{MHz}$

$m=0.5$ $f_m=5\text{KHz}$

$R=1\text{ ohm}$

- To Find : i) Total transmitted power P_t
 ii) SSB power $P(ssb)$
 iii) Percentage of power saving if SSB is transmitted
 iv) Bandwidth (B.W)

$$\text{Formulas : } P_c = \frac{E_c^2}{2R}, P(\text{USB}) = P(\text{LSB}) = \frac{(m.E_c)^2}{8R}, m = \frac{E_m}{E_c}, P_t = P_c \left[1 + \frac{m^2}{2} \right]$$

$$\% \text{ Power Saving if SSB is transmitted} = \frac{P_t - P(ssb)}{P_t}$$

Solution :

Using formulas ,

$$E_c = \sqrt{P_c \times 2R} = \sqrt{20000} = 141.421 \text{ V}$$

Total Transmitted power ,

$$P_t = P_c \left[1 + \frac{m^2}{2} \right] = 10 \left[1 + \frac{0.5^2}{2} \right] = 11.25 \text{ KW}$$

SSB Power i.e single side band power ,

$$P(\text{USB}) = P(\text{LSB}) = \frac{(m.E_c)^2}{8R} = \frac{(0.5 \times 141.241)^2}{8 \times 1} = 0.624 \text{ KW}$$

$$\begin{aligned} \% \text{ Power Saving if SSB is transmitted} &= \frac{P_t - P(ssb)}{P_t} \times 100 = \\ &= \frac{11.25 - 0.624}{11.25} \times 100 \\ &= 94.45\% \end{aligned}$$

$$\text{Bandwidth} = B.W = 2 \cdot f_m = 2(5\text{KHz}) = 10\text{KHz.}$$

Frquency Spectrum ,

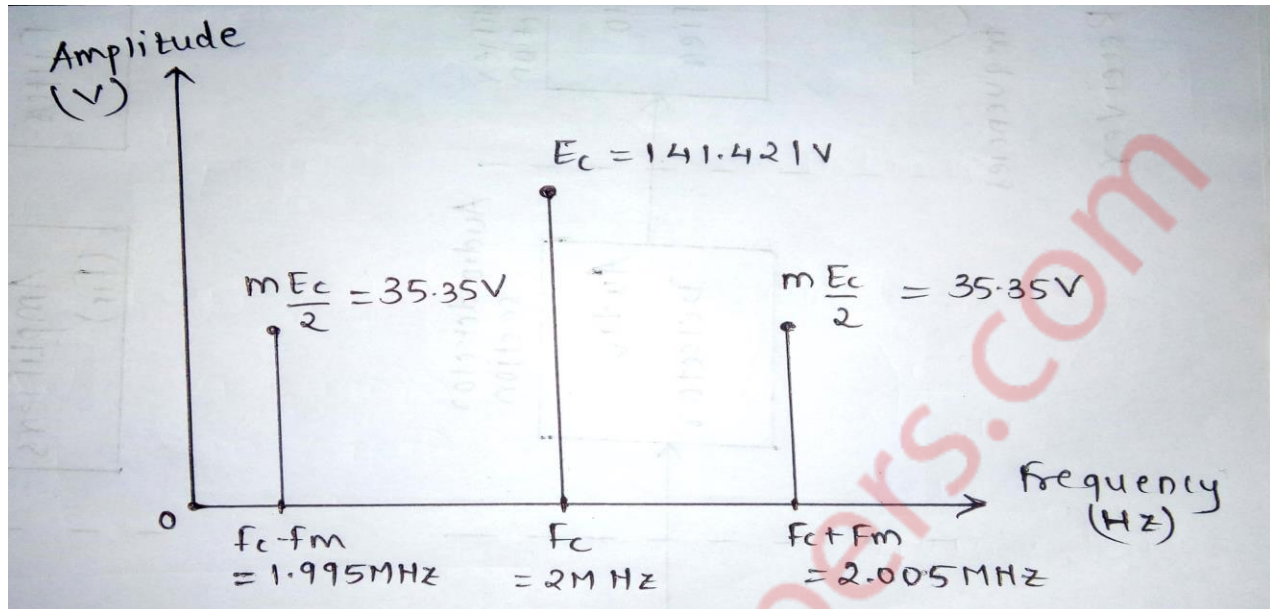

Q.3 a) Explain FM demodulator using PLL with suitable diagram.

[10M]

Ans :

i) The phase locked loop takes in a signal to which it locks and can then output this signal from its own internal VCO. At first sight this may not appear particularly useful, but with a little ingenuity, it is possible to develop a large number of phase locked loop applications.

ii) **FM demodulation:** One major phase locked loop application is that of a FM demodulator. With PLL chips now relatively cheap, this PLL application enables high quality audio to be demodulated from an FM signal.

iii) A phase locked loop, PLL, is basically of the form of a servo loop. Although a PLL performs its actions on a radio frequency signal, all the basic criteria for loop stability and other parameters are the same. In this way the same theory can be applied to a phase locked loop as is applied to servo loops.

iv) A basic phase locked loop, PLL, consists of three basic elements:

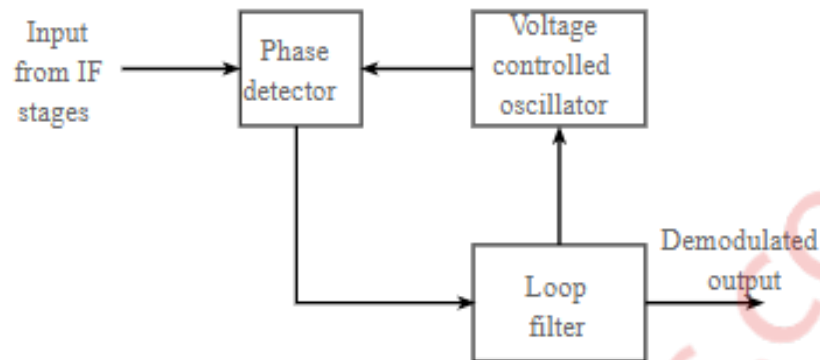

PLL Phase locked Loop FM demodulator

Phase comparator / detector: As the name implies, this circuit block within the PLL compares the phase of two signals and generates a voltage according to the phase difference between the two signals. This circuit can take a variety of forms.

Voltage controlled oscillator, VCO: The voltage controlled oscillator is the circuit block that generates the radio frequency signal that is normally considered as the output of the loop. Its frequency can be controlled over the operational frequency band required for the loop.

Loop filter: This filter is used to filter the output from the phase comparator in the phase locked loop, PLL. It is used to remove any components of the signals of which the phase is being compared from the VCO line, i.e. the reference and VCO input. It also governs many of the characteristics of the loop including the loop stability, speed of lock, etc

v) In the basic PLL, reference signal and the signal from the voltage controlled oscillator are connected to the two input ports of the phase detector. The output from the phase detector is passed to the loop filter and then filtered signal is applied to the voltage controlled oscillator.

vi) The Voltage Controlled Oscillator, VCO, within the PLL produces a signal which enters the phase detector. Here the phase of the signals from the VCO and the incoming reference signal are compared and a resulting difference or error voltage is produced. This corresponds to the phase difference between the two signals.

vii) The error signal from the phase detector passes through a low pass filter which governs many of the properties of the loop and removes any high frequency elements

on the signal. Once through the filter the error signal is applied to the control terminal of the VCO as its tuning voltage.

viii) The sense of any change in this voltage is such that it tries to reduce the phase difference and hence the frequency between the two signals. Initially the loop will be out of lock, and the error voltage will pull the frequency of the VCO towards that of the reference, until it cannot reduce the error any further and the loop is locked.

ix) When the PLL, phase locked loop, is in lock a steady state error voltage is produced. By using an amplifier between the phase detector and the VCO, the actual error between the signals can be reduced to very small levels. However some voltage must always be present at the control terminal of the VCO as this is what puts onto the correct frequency.

x) The fact that a steady error voltage is present means that the phase difference between the reference signal and the VCO is not changing. As the phase between these two signals is not changing means that the two signals are on exactly the same frequency.

b) Explain amplitude limiting and thresholding in detail with its significance. [10M]

Ans :

i) Amplitude limiting is “a process in which the amplitude of output signal is limited to a desired level or margin irrespective of the variations in the input signal”.

ii) Amplitude limiter is an electronic device which clips (removes) the amplitude of output signals to a desired margin irrespective of variations in the input signal

iii) The undesirable input amplitude is clipped by a limiter circuit and gives the desirable margin of output.

iv) Amplitude limiters are used in FM (Frequency modulation) receivers to eliminate the undesirable amplitude changes caused by noise.

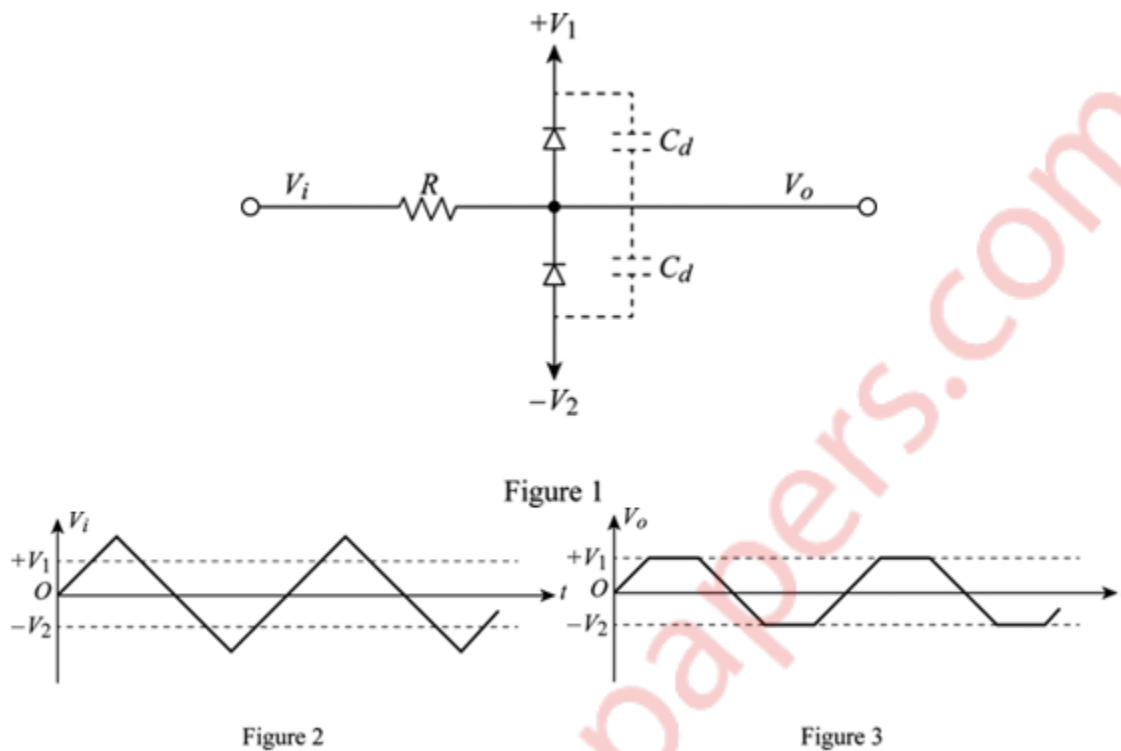

v) Figure 1 is the amplitude limiting circuit. Here, the diodes act as clippers. It clips the undesirable magnitude of output signal. Capacitors act as ripple removers for the output signal.

vi) Figure 2 is the input triangle signal applied to amplitude limiter circuit. The desired output voltage margin should be between $-V_2$ to V_1 .

vii) Figure 3 is the output signal from the limiter circuit. The undesirable input amplitude is clipped by a limiter circuit and gives the desirable margin of output. Amplitude limiters are used in FM (Frequency modulation) receivers to eliminate the undesirable amplitude changes caused by noise.

viii) Threshold effect is defined as the value of input signal to noise ratio below which the output signal to noise ratio decreases much rapidly than the input signal to noise ratio. It is the property of envelope detectors used for the demodulation of modulated signals.

ix) It occurs due to presence of large noise and therefore causes loss in the message signal. When the noise is very large as compared to the input at envelope detector, the message signal at the output is mixed with noise.

x) Ratio detector is a frequency de-modulator circuit in which amplitude limiting and thresholding is provided. In ratio detector output voltage is equal to half of the difference between output voltages from individual diodes.

Output voltage is proportional to the difference between individual output vo

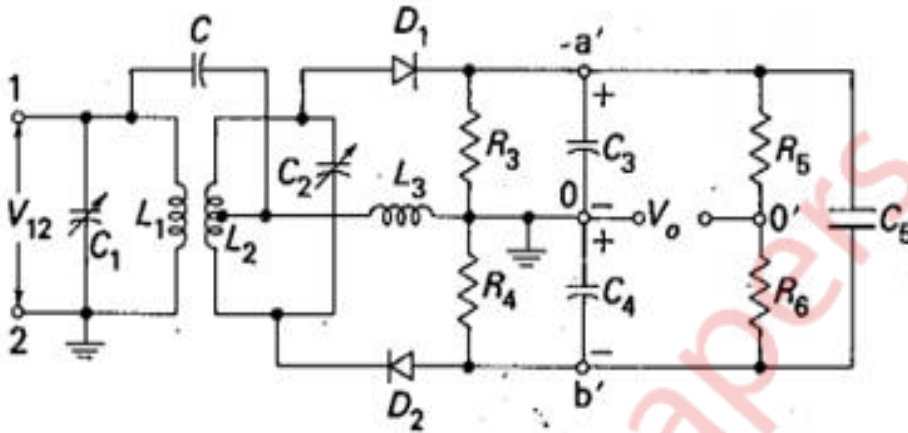

Q.4 a) Explain Varactor diode modulator.

[10M]

Ans :

- i) Varactor diode modulator is the direct method of FM generation wherein the carrier frequency is directly varied by the modulating signal.
- ii) A varactor diode is a semiconductor diode whose junction capacitance varies linearly with applied voltage when the diode is reverse biased.
- iii) Varactor diodes are used along with reactance modulator to provide automatic frequency correction for an FM transmitter.
- iv) Varactor diode is arranged in reverse bias to offer junction capacitance effect. The modulating voltage which is in series with the varactor diode will vary the bias and hence the junction capacitance, resulting the oscillator frequency to change accordingly.
- v) The external modulating AF voltage adds to and subtracts from the dc bias, which changes the capacitance of the diode and thus the frequency of oscillation.

vi) Positive alternations of the modulating signal increase the reverse bias on the varactor diode, which decreases its capacitance and increases the frequency of oscillation.

vii) Conversely, negative alternations of the modulating signal decrease the frequency of oscillation.

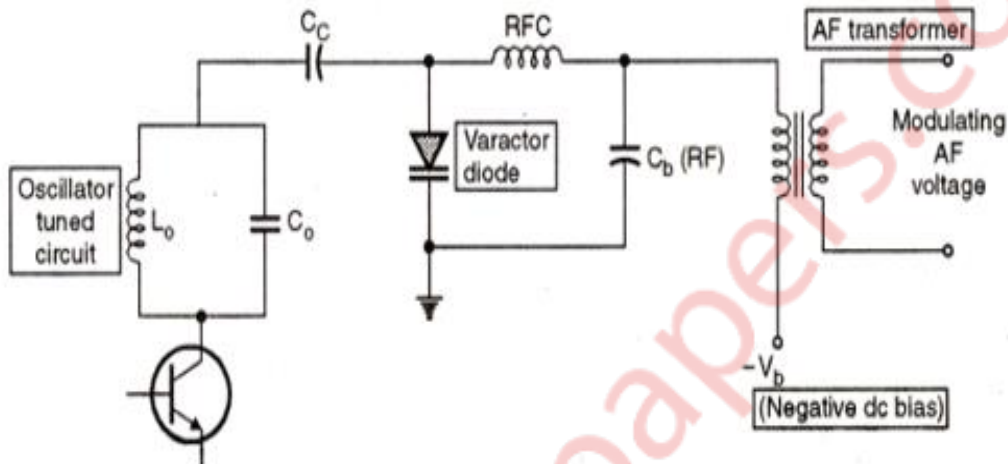

viii) The RFC and capacitor C_b act as a filter which transmits only the AF variations to the varactor diode and blocks high frequency RF voltage from reaching the AF stage.

ix) The varactor diode FM modulators are widely accepted because they are simple to use, reliable and have the stability of a crystal oscillator.

x) This method of FM generation is direct because the oscillator frequency is varied directly by the modulating signal, and the magnitude of frequency change is proportional to the amplitude of the modulating signal voltage.

xi) Varactor diode modulator is used for automatic frequency control and remote tuning.

xii) The drawback of varactor diode modulator is that since it uses a crystal, the peak frequency deviation is limited to relatively small values. Thus they are used mostly for low index applications such as two way mobile radio. Also since they are a two terminal device, the applications are quite limited.

b) With the help of suitable waveforms explain generation and detection of PPM.

[10M]

Ans : i) Pulse position modulation : The amplitude and the width of the pulse remains constant. The time when the pulse occurs is varied in accordance with the modulating signal.

ii)Pulse Width Modulation : The amplitude of the pulse is maintained constant but the width of each pulse is varied according to the modulating signal.

iii)Saw tooth generator: – The saw tooth generator is conneted to the inverting terminal of the operational amplifier (Opamp). The Op-amp is used in comparator mode.

iv)Modulating signal: – The modulating signal is given as input to the non inverting terminal of the Op-amp as comparator.

v)PWM & PPM generation PWM generation: – The output of the comparator is zero except when modulating signal waveform exceeds the sawtooth wave, when the output is high.

vi) PPM generation: – The output of the comparator (i.e. PWM) is given as input to negative edge triggered monostable pulse generator. – On the trailing edge (negative going edge) of the PWM signal produces a short pulse of fixed duration. This output is PPM signal.

vii) Advantage: – Less noise interference due to constant amplitude. – Signal and noise separation is very easy. – Due to constant pulse width & amplitudes, transmission power for each pulse is same.

vii) Disadvantage – Synchronization between transmitter & receiver is required.

viii) Applications of PPM :

R/C transmitters,R/C receivers ,Autopilot/Stabilization system,PCTx

ix) PPM and PWM are used to send analog signals, not digital signals. They are analog protocols.

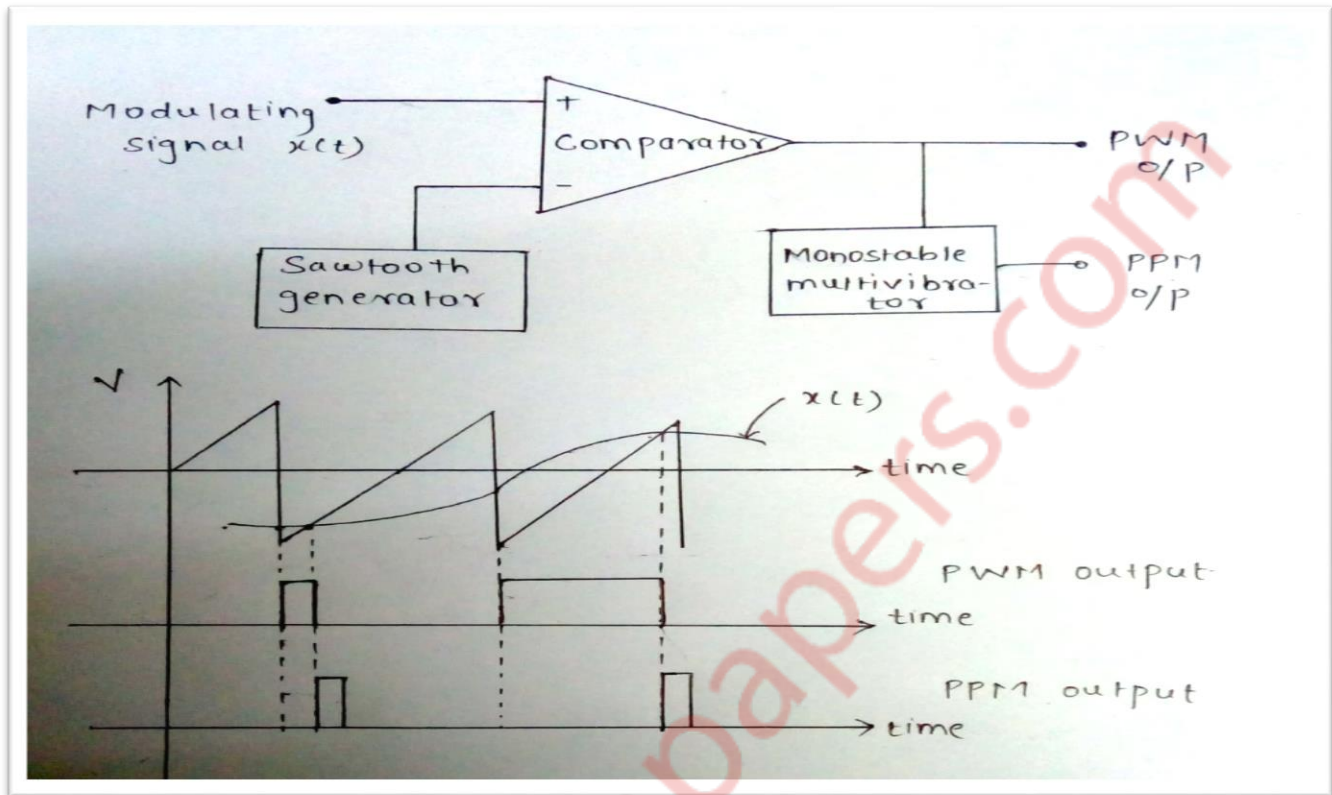

x) Role of monostable multivibrator : When triggered , a pulse of predefined duration is produced. The circuit then returns to its stable state and produces no more output until triggered. In PPM generation the pulse is generated whenever the PWM pulse is high. And the duration of PPM pulse generated by monostable multivibrator is constant for each triggered pulse.

Q.5 a) Explain independent side band receiver in detail with block diagram. [10M]

Ans : i) Independent sideband is an AM single sideband mode which is used with some AM radio transmission. Normally each sideband carries identical information, but ISB modulates two different input signals, one on the upper side band, the other on the lower sideband.

ii) Independent sideband is an amplitude modulated technique in which a single carrier frequency is independently modulated by two different modulating signals.

iii) The two sidebands are generated independently by the two balanced modulators. The carrier is suppressed by 45 dB or more in the balanced modulator and the following filter suppresses the undesired sideband. The output from both the filters are then combined in the adder along with 26dB carrier to form low frequency ISB signal which then leaves the drive unit and enters the main transmitter.

iv) Its frequency is raised through mixing to remove unwanted frequencies by the output filter and the resulting RF ISB signal is then amplified to the desired level.

v) ISB conserves both the transmit power and the bandwidth, since the two information signals are transmitted within the same frequency spectrum as against a single signal in traditional DSB transmission system.

vi) ISB Transmission : ISB essentially consists of two SSB channels added to form two side bands around the reduced carrier. Each sideband is quite independent of each other. It can simultaneously convey totally different transmission.

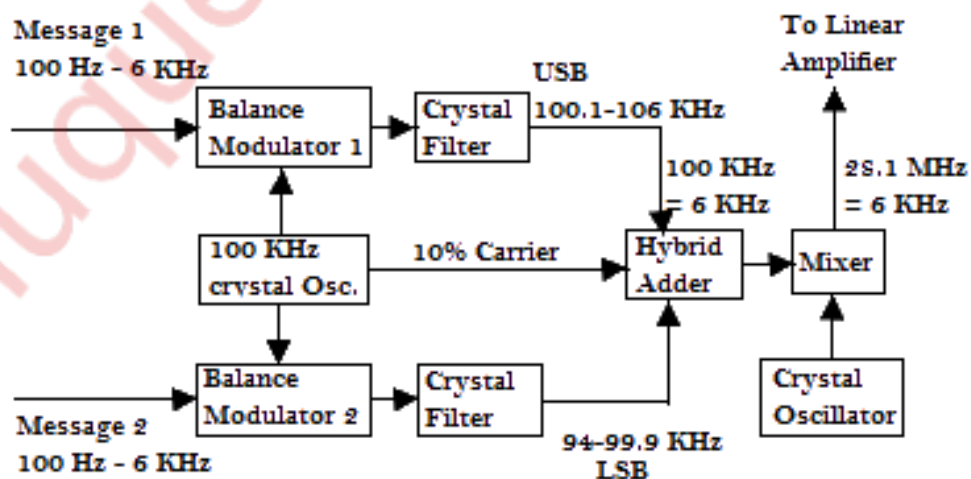

ISB Transmission Block Diagram

vii) Each 100 Hz - 6 KHz channel is fed to its own balanced modulator, each modulator also receiving the output of the 100 KHz crystal oscillator. Each modulator modulates each message (100Hz to 6KHz) on the frequency 100 KHz.

viii) The USB filter and LSB filter suppresses the unwanted side band in such a way that one filter suppresses the lower side band and the other filter suppresses the upper side band respectively. So USB = 100.1 - 106 KHz & LSB = 94 - 99.9 KHz

ix) Both outputs are added at the hybrid adder with the 10% reduced carrier. The output is then fed to the balanced mixer where it is mixed with the output of the crystal oscillator, the frequency is then raised to 28.1 MHz \pm 6 KHz. The resulting RF ISB signal is then amplified by the linear amplifier, until it reaches the ultimate level then is fed to the antenna for transmission.

x) ISB Receiver :

A receiver for independent sideband (ISB) signals comprises means for producing digitised quadrature related zero IF versions of the received signal which are applied to a complex FIR filter structure comprising respective real low pass filters in which alternate coefficients (C_1 to C_{N-1} , C_0 to C_N) are non-zero.

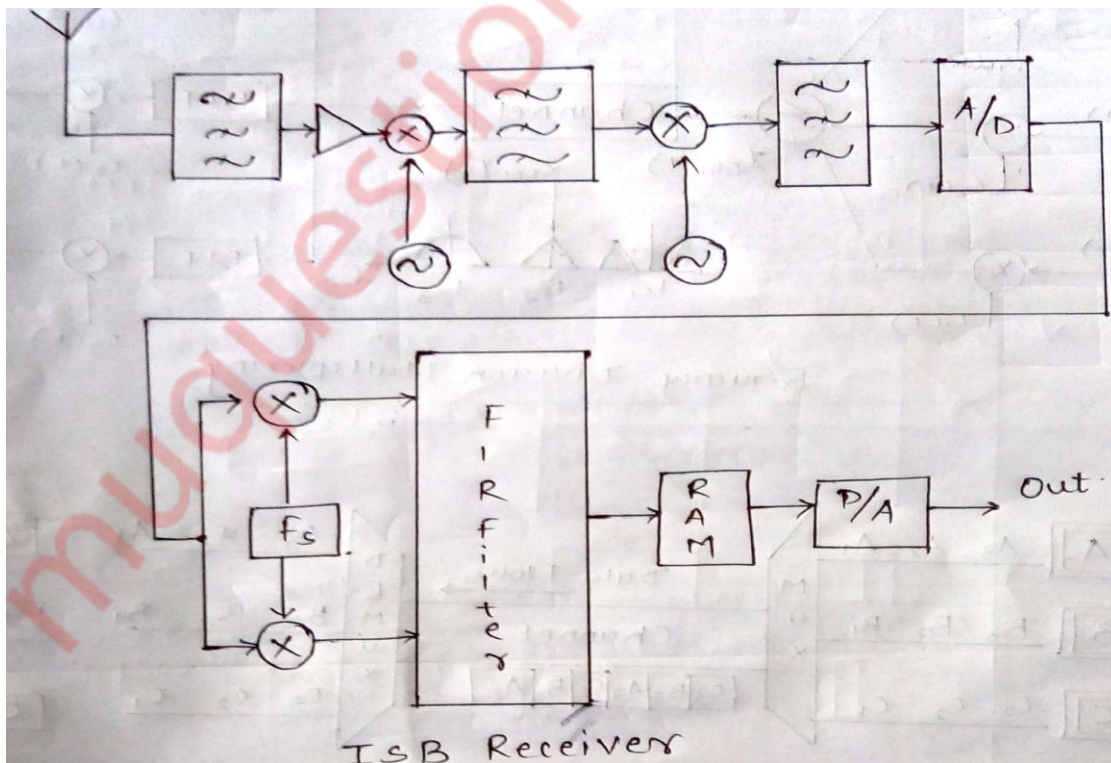

xi) The respective upper and lower sidebands (USB, LSB) are recovered by obtaining the sum and difference of the outputs of the respective filters.

xii) The respective sideband signals (USB, LSB) are stored in RAM and when it is desired to reproduce the stored signal it is expanded, equalised and converted to an analogue signal which is supplied to an audio transducer.

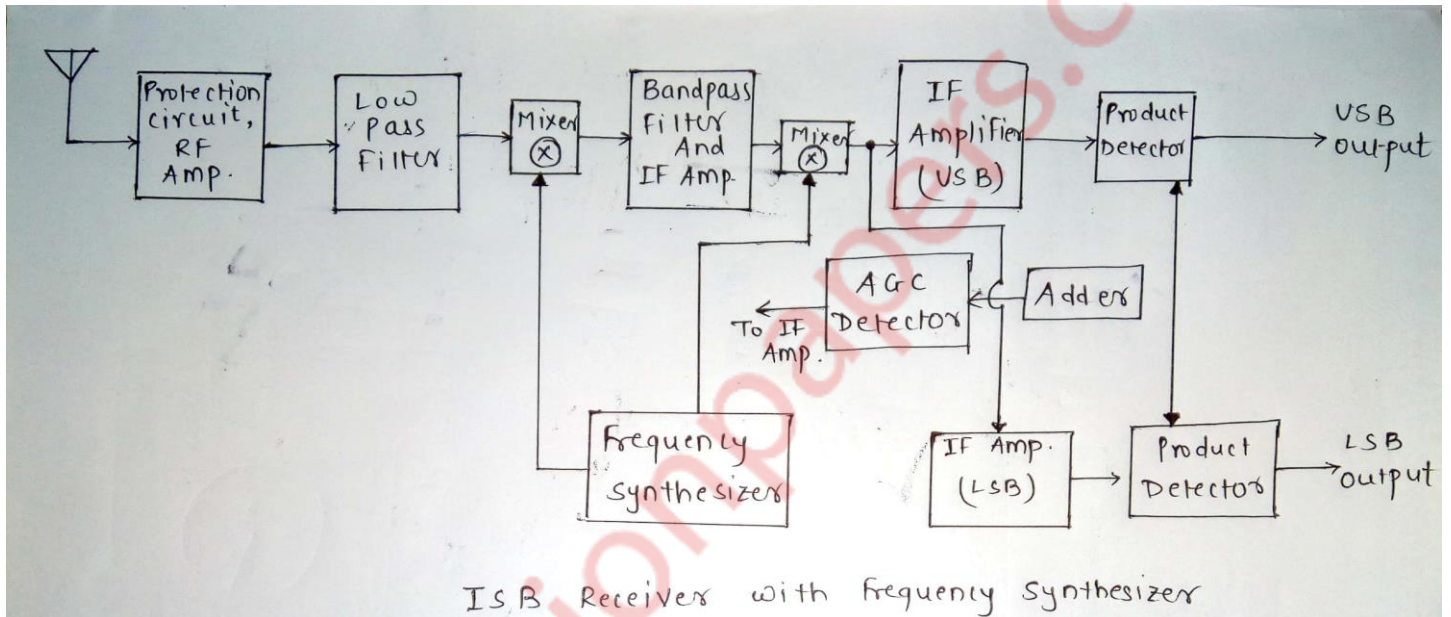

b) Compare Amplitude ,Frequency and phase modulation.**[10M]****Ans :**

No.	Amplitude Modulation	Frequency Modulation	Phase Modulation
1.	Amplitude of carrier wave varies as per amplitude of modulating signal.	Frequency of carrier wave varies as per voltage of modulating signal.	Phase of carrier wave varies as per voltage of modulating signal.
2.	Frequency of carrier wave is kept constant.	Amplitude of carrier wave is kept constant.	Amplitude of carrier wave is kept constant.
3.	Requires more bandwidth.	Theoretically, it needs infinite bandwidth.	Bandwidth requirement depends upon modulating signal frequency.
4.	$BW = 2fm$ Bandwidth is independent of modulating index m .	Bandwidth of FM remains almost constant	In PM , $BW \propto fm$
5.	AM types includes DSB-FC,SSB,VSB,etc	Digital FM types includes FSK,GFSK,offset FSK.	Digital PM types includes BPSK,QPSK,QAM.
6.	AM transmitter can transmit upto long distance	FM transmitter can transmit upto short distance	Long distance communication possible.
7.	Range 535 – 1705 Khz upto 1200 bps.	Range 88 – 108MHz upto 1200 – 2400 bps	ASK + PSK = QAM
8.	Impacted with environmental noise.	It does not degrade linearly with distance and it is impacted with physical barrier.	While phase changes frequency changes and impacts according to frequencies.
9.	Applications : AM radio broadcasting	Applications : FM broadcasting , TV,radio	Applications : Optical Fibre
10.	Superhetrodyne , Tuned radio frequency receivers are used in receiving AM signal.	Receiver – GNU FM receiver	Receiver – Phase lock loop system

Q.6 Write short note on (any four).

[20M]

a) Aliasing error and aperture effect

Ans : i) Aliasing effect take place when sampling frequency is less than Nyquist rate under such condition, the spectrum of the sampled signal overlaps with itself.

ii) Hence higher frequency components are called aliasing effect.

iii) The aliased signal will appear at a predictable frequency in the Fourier spectrum. For example, given a sampling frequency of 200Hz (Nyquist frequency = 100Hz), a digitized 101Hz signal will appear at 99Hz, while a 200Hz signal will appear at 0Hz or DC. A 201Hz signal will look like a 1Hz signal, and so on.

iv) In flat top sampling, due to the lengthening of the sample, amplitude distortion as well as a delay of $T/2$ was introduced. This distortion is referred to as Aperture effect.

v) Aperture effect can be corrected by connecting an equalizer in cascade with the low pass reconstruction filter.

vi) This equalizer has the effect of decreasing the in-band loss of reconstruction filter as the frequency increases in such a manner as to compensate for the aperture effect.

b) Applications of Pulse Communication

Ans : i) Pulse amplitude modulation is used in Ethernet communication.

ii) Pulse amplitude modulation is used in many micro-controllers for generating the control signals.

iii) Pulse amplitude modulation is used in Photo-biology.

iv) PAM is used as an electronic driver for LED lighting.

v) The PCM is used in the satellite transmission system.

vi) It is used in space communication.

vii) It is used in telephony.

viii) The compact disc (CD) is a recent application of PCM.

ix) PWM is used in telecommunication systems.

x) PWM can be used to control the amount of power delivered to a load without incurring the losses. So, this can be used in power delivering systems. Audio effects and amplifications purposes also used. PWM signals are used to control the speed of the robot by controlling the motors. PWM is also used in robotics.

c) VSB transmission with its applications

Ans :

- i) Vestigial sideband (VSB) is a type of amplitude modulation (AM) technique (sometimes called VSB-AM) that encodes data by varying the amplitude of a single carrier frequency .
- ii) Portions of one of the redundant sidebands are removed to form a vestigial sideband signal - so-called because a vestige of the sideband remains.
- iii) In AM, the carrier itself does not fluctuate in amplitude. Instead, the modulating data appears in the form of signal components at frequencies slightly higher and lower than that of the carrier.
- iv) These components are called sidebands . The lower sideband (LSB) appears at frequencies below the carrier frequency; the upper sideband (USB) appears at frequencies above the carrier frequency.
- v) The actual information is transmitted in the sidebands, rather than the carrier; both sidebands carry the same information.
- vi) Because LSB and USB are essentially mirror images of each other, one can be discarded or used for a second channel or for diagnostic purposes.
- vii) VSB transmission is similar to single-sideband (SSB) transmission, in which one of the sidebands is completely removed. In VSB transmission, however, the second sideband is not completely removed, but is filtered to remove all but the desired range of frequencies.

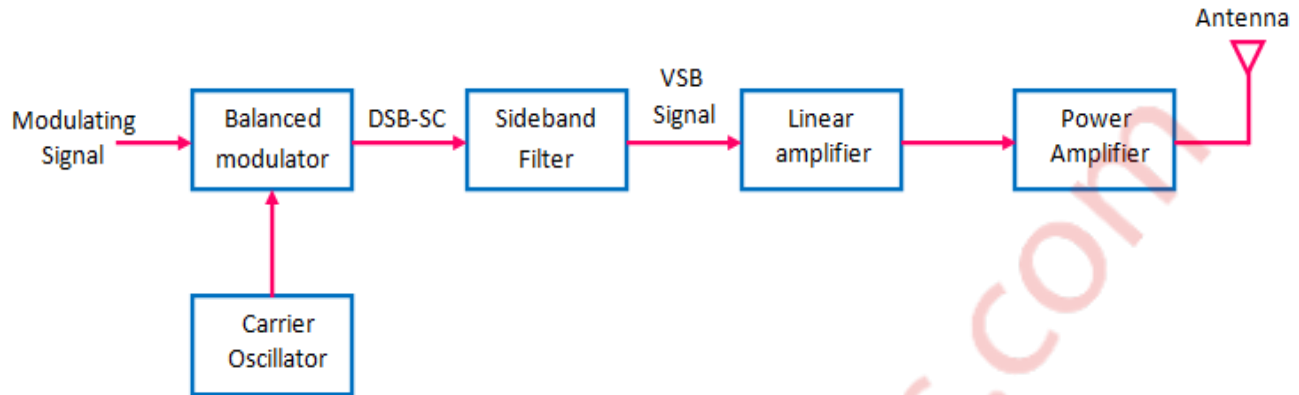

viii) Advantages :-

- Highly efficient.
- Reduction in bandwidth.
- Filter design is easy as high accuracy is not needed.
- The transmission of low frequency components is possible, without difficulty.
- Possesses good phase characteristics.

ix) Disadvantages

- Bandwidth when compared to SSB is greater.
- Demodulation is complex.

d) Time Division Multiplexing (TDM)

Ans : i) Signal multiplexing is a process in which multiple signals can be transmitted over the same communication medium simultaneously.

ii) If the analog signals are multiplexed, then it is called as analog multiplexing. Similarly, if the digital signals are multiplexed, then it is called as digital multiplexing.

iii) Time division multiplexing (FDM) is a technique of multiplexing, where the users are allowed the total available bandwidth on time sharing basis. Here the time domain is divided into several recurrent slots of fixed length, and each signal is allotted a time slot.

iv) TDM is digital multiplexing technique. In TDM, the channel/link is not divided on the basis of frequency but on the basis of time.

v) Total time available in the channel is divided between several users.

vi) Each user is allotted a particular a time interval called time slot or time slice during which the data is transmitted by that user.

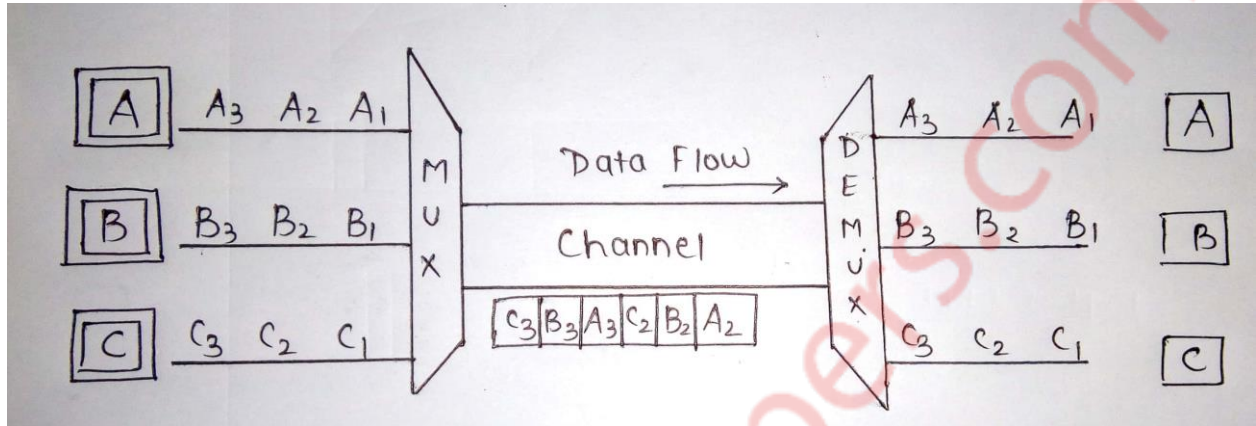

vii) Thus each sending device takes control of entire bandwidth of the channel for fixed amount of time.

viii) In TDM the data rate capacity of the transmission medium should be greater than the data rate required by sending or receiving devices.

ix) Thus each signal will be transmitted for a very short time. One cycle or frame is said to be complete when all the signals are transmitted once on the transmission channel.

x) The TDM system can be used to multiplex analog or digital signals, however it is more suitable for the digital signal multiplexing. The TDM signal in the form of frames is transmitted on the common communication medium.

Advantages of TDM :

1. Full available channel bandwidth can be utilized for each channel.
2. Intermodulation distortion is absent.
3. TDM circuitry is not very complex.
4. The problem of crosstalk is not severe.

Disadvantages of TDM :

1. Synchronization is essential for proper operation.
2. Due to slow narrowband fading, all the TDM channels may get wiped out.

e) Low level and high level modulation.

Ans :

A. HIGH LEVEL MODULATION:

1. Power level: modulation takes place at high modulation level.
2. Types of amplifier: highly efficient class c amplifiers are used.
3. Efficiency: very high.
4. Devices used: vacuum tubes or transistor for medium power applications.
5. Design of AF power amplifier: complex due to very high power involved.
6. Applications: high power broadcast transmitters.

B. LOW LEVEL MODULATION:

1. Power level: modulation takes place at low power level.
2. Types of amplifier: linear amplifiers are used after modulation
3. Efficiency: lower than high level modulators.
4. Devices used: transistors, JFET, OP-AMPS.
5. Design of AF amplifier: easy as it is to be done at low power.
6. Applications: sometimes used in tv transmitters(IF modulation).