

Duration -3 hours

Marks -80

N.B.

- (1) Question No.1 is compulsory and Answer 3 Questions out of remaining 5 Questions.
- (2) Assume suitable data wherever necessary
- (3) Figurers to the right indicate full marks.

- Q.1 a) Give reasons for **any five** of the following statements. 15
- i) Grain direction of the strip is a consideration in locating the blank when bending operation is required.
 - ii) Guide bushes and pillars are always hardened
 - iii) Segmental die construction is preferred over solid one piece construction.
 - iv) Compound dies are used for close tolerance work parts.
 - v) Ejectors is essential for U bending die.
 - vi) Dowels are located diagonally across each other and as a part as possible.
 - vii) Pilots are always hardened.
- b) Explain construction and working of inverted blanking die. 05
- Q.2 a) Part shown in figure is to be produced on progressive die.
- i) Draw an economical strip layout. Consider sheet size 300x 1200mm. 06
 - ii) Calculate tonnage required for the layout. 04
 - iii) Draw the following views of progressive die. 10
- Plan view of bottom assembly and sectional front elevation.

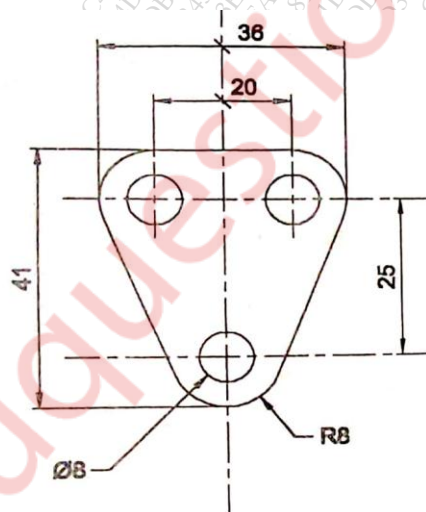

MATERIAL : BRASS SHEET
THICKNESS : 1.6 MM
ALL DIMENSIONS ARE IN MM
ULTIMATE SHEAR STRENGTH : 40 Kg/MM²
SHEET SIZE: 300MM X 1200MM

- Q.3 A) 0.8 mm thick circular cup as shown in figure no. 2 is manufactured by using deep drawing operation. Determine following. 20
- i) Blank size
 - ii) Percentage reduction
 - iii) Number of draws
 - iv) Radius on punches and dies
 - v) Die clearance, punch diameter and die opening size at each draw

- vi) Drawing force and blank holding force
(Yield strength of material : 350 N/mm²)

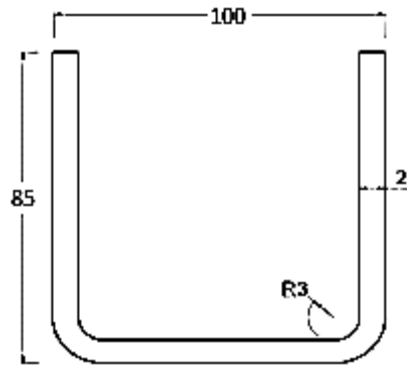

Fig No.2
Deep Drawn Component
(All Dimensions are in mm)

- Q.4 A) A press is designed to offer 90 ton of force at 20° crank angle with a stroke of 15cm. Stroke is variable from 1cm to 15cm. Calculate tonnage available when ram is 3cm above its BDC. Take stroke length equal to 10cm. **06**
- B) Explain various methods of reducing maximum cutting force requirement in a cutting operation. **07**
A 5 mm thick M. S. plate is cut on a shearing machine and length of cut is 550 mm. The shear strength of material is 500N/ sq. mm. find the cutting force requirement with the cutting blade inclined at 2degrees, if the percent penetration is 40%.
- C) Explain with the help of neat sketch working of Combination Die. **06**
- Q.5 A) Differentiate between the following (Any two) :- **10**
I) Coining and embossing
II) Shaving and trimming
III) Hydraulic press and mechanical press
- B) A press has minimum DLH of 400 mm and adjustment of ram is 60 mm. Stroke can be varied from 120 mm to 10 mm. If the bolster plate provided has thickness of 70 mm, determine minimum and maximum shut for a die. **05**
- C) What is direct pilot? What are advantages of direct pilot? Why should indirect pilot be spring loaded when used on material over 1.6mm thick? **05**
- Q.6 Write short note on the following. **20**
a) Methods of reducing spring back in bending.
b) Explain methods of Feeding stock in press.
c) Write safety precautions taken in the press shop.
d) Compound Die