

Duration: 3 hours

Total Marks : 80

Note :

- Question No.1 is compulsory.
- Solve ANY THREE questions from the remaining five questions.
- Figure to the right indicates full marks.
- Assume suitable data wherever required, but justify the same.
- Take $g = 9.81 \text{ m/s}^2$.

Q.1 Solve ANY FOUR questions from the following. (Each question carries 5 marks). 20

- a) Determine the tension in cord AB and BC for the equilibrium of the 30 kg block as shown in the figure.

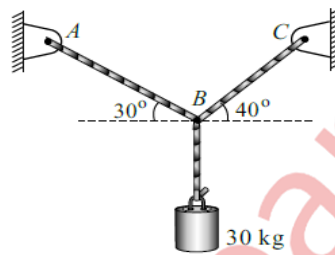

- b) Define the Instantaneous Centre of Rotation and write the properties of Instantaneous Centre of Rotation.
- c) Acceleration of a particle moving along a straight line is represented by the relation $a = t^3 - 2t^2 + 7$. At $t = 1$ second, velocity of the particle is 3.58 m/s and displacement is 9.39 m. Determine the velocity and displacement at $t = 2$ seconds.
- d) Define laws of friction.
- e) Determine the centroid of the shaded area.

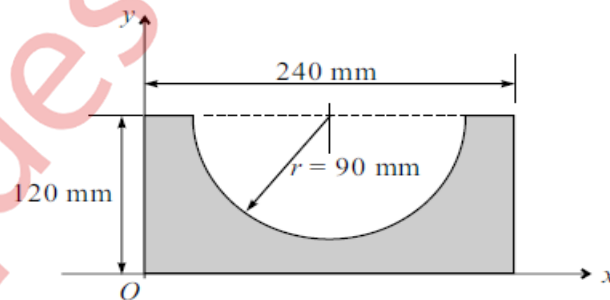

Q.2 a) Two identical cylinders of weight 200 N and diameter 100 mm are placed as shown in figure. Determine the support reactions at A, B and C. 8

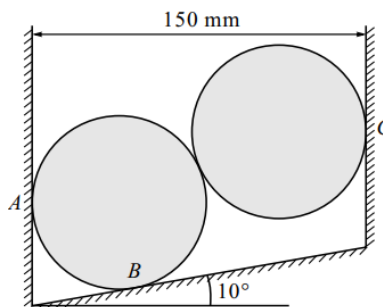

- b) Calculate the resultant of the given force system and locate it with respect to the point of action of 200 N force. 6

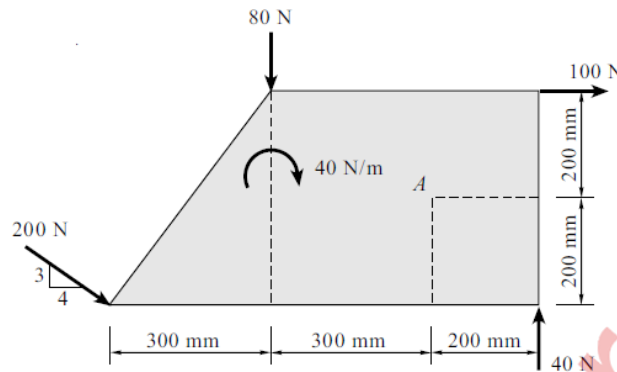

- c) Determine the “x” and “y” coordinates of the Centroid for the shaded area shown. 6

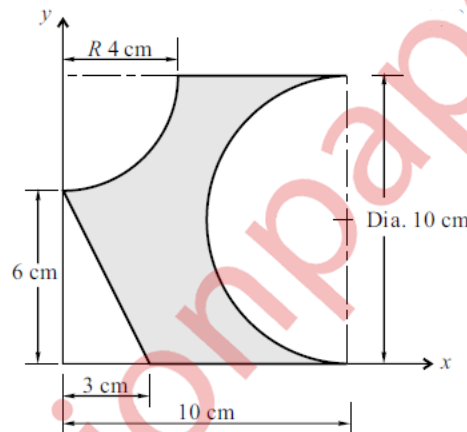

- Q.3 a) A ball is thrown with a speed of 12 m/s at an angle of 60° with a building strikes the ground 11.3 m horizontally from the foot of the building. Determine the height of the building. 8

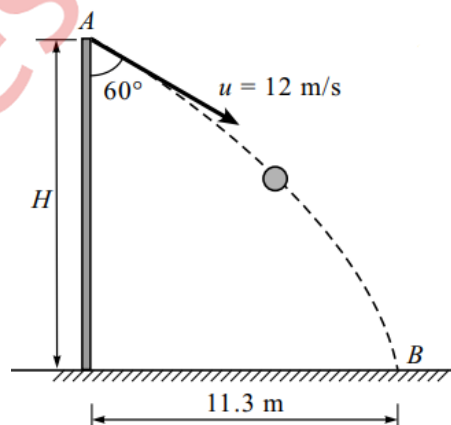

- b) A block of 1000 N is placed on an inclined surface. Determine the force required to prevent the sliding of the block down the plane if the coefficient of friction between the block and surface is 0.15. 6

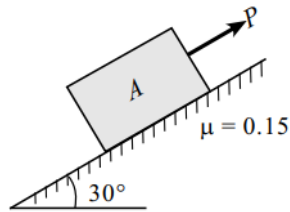

- c) A particle follows the path $y = 0.4x^2$ with a constant speed of 200 m/s at a rate of 0.8 m/s^2 . Determine the acceleration of the particle. 6

- Q4** a) A 20 N block is released from rest. It slides down a rough incline having coefficient of friction 0.2 and compresses the spring having modulus 1000 N/m. Determine the maximum compression of the spring and the distance moved by block when the energy is released by the spring. 8

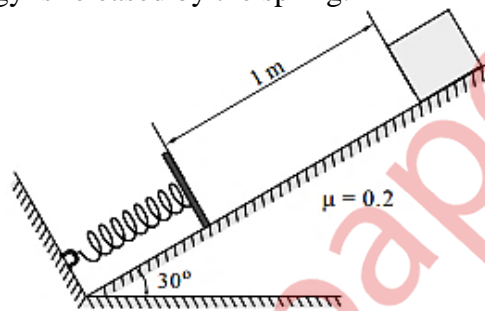

- b) At the instant shown, locate the ICR and determine the angular velocity of rod BC and the velocity of the piston C. (Take $AB=10.3 \text{ m}$, $BC=0.8 \text{ m}$) 6

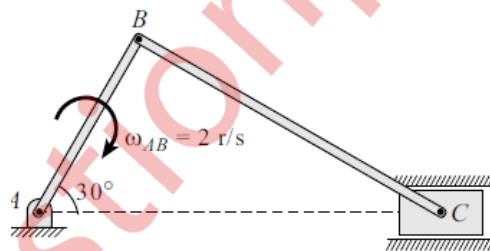

- c) A ball is thrown vertically down on a smooth horizontal floor with a velocity of 10 m/s from which it bounces to a height of 3 m. If the coefficient of restitution is 0.7. Find the maximum height it can reach after hitting the ground. 6

- Q5.** a) The a-t curve is shown for a particle moving in a straight line. Draw the v-t and s-t diagram for 0-10 sec, if the particle has started from rest from the origin. 8

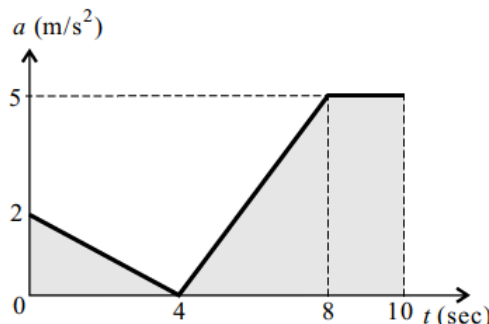

- b) For the system shown in figure, determine the acceleration and velocity of block A after it has moved 2.7 m when pulled by 90 N. 6

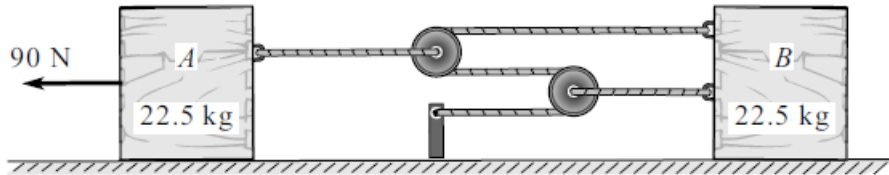

- c) A force $F = 3i - 4j + 12k$ N acts at a point "A (1,-2,3) m. Calculate (i) Moment of the force about the origin. (ii) Moment of the force about a point B(2,1,2). 6

- Q6 a) A beam is loaded and supported as shown in figure. Find the support reactions at support B and Force P if the reaction at support A is zero. 8

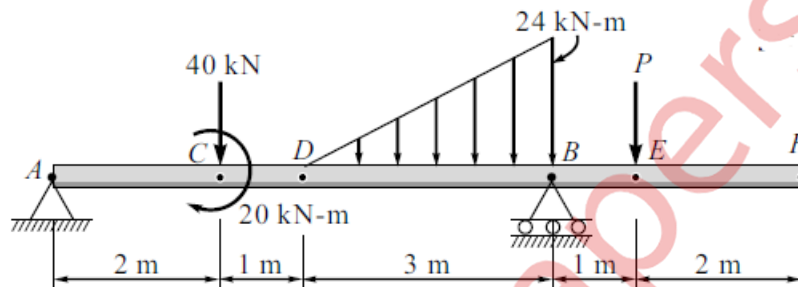

- b) Block A weighs 40 kN and the block B weighs 60 kN. The coefficient of friction between A and B is 0.3 and between B and the floor is 0.25. Determine the value of "P" for holding the system in equilibrium. 6

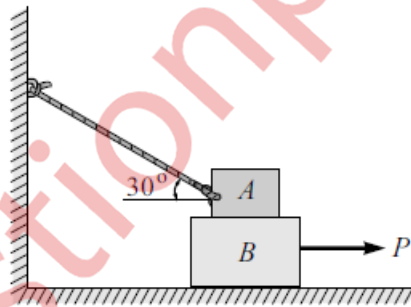

- c) Determine the resultant of the system of parallel forces and the position on X-Z plane. 6

