

(3 Hours)

[Total Marks: 80]

- N.B.: (1) Question No. 1 is **Compulsory**.
 (2) Attempt any **three** questions out of the remaining **five**.
 (3) Each question carries 20 marks and sub-question carry equal marks.
 (4) Assume suitable data if required.

1. Attempt any Four (20)

- (a) Explain parts of DC machines and their function. Diagrams are not expected (5)
- (b) If a voltage of $v=200\sin(314t - 20^\circ)$ V is being applied to an impedance. A current of $5\angle 30^\circ$ A flows through the circuit. Find resistance, reactance and pf of the circuit. (5)
- (c) A three phase star connected load has a pf 0.8 lag. Two wattmeters are connected to measure power input. Total power in the circuit is 10KW. Find readings of each wattmeter. (5)
- (d) A voltage of 200V is being applied to an impedance containing resistance of 20 ohm in series with capacitive reactance of 10 ohm. Find admittance of the circuit and hence calculate current using admittance. (5)
- (e) Find the current in inductor for the circuit shown. (5)

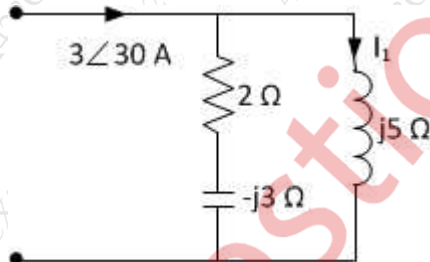

2. (a) Prove that two wattmeter method can measure power in three phase circuit. (10)

- (b) A balanced 3 phase load connected in delta, draws a power of 10kW at 440V at a power factor of 0.6 load, find the values of circuit elements and the reactive volt amperes. (10)

3. (a) Find current in 10Ω by mesh analysis. (10)

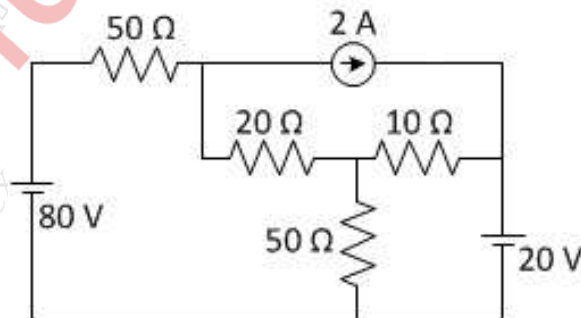

(10)

- (b) Find current through 1 ohm by Thevenin's theorem.

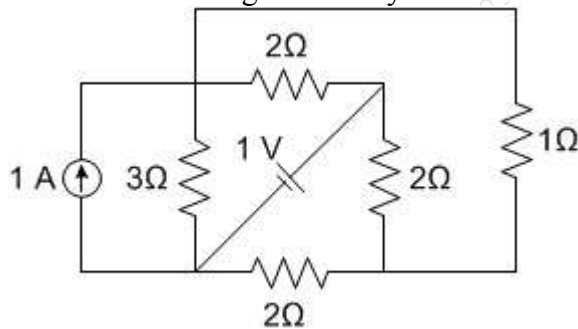

4. (a) An ac circuit consists of pure resistance and an inductive coil connected in series. The power dissipated in the resistance and the coil are 1000W and 200W respectively. The voltage drop across the resistance and coil are 200V and 300V respectively. Calculate the following. (10)
 (i) Value of resistance (ii) current through coil (iii) resistance of coil (iv) impedance of coil (v) total impedance of circuit
 (b) Derive an expression for emf induced in DC machine. (5)
 (c) Explain working of single stack variable reluctance stepper motor. (5)
- 5 (a) Four impedances are connected in series. Voltage drops across three of them are $v_1=282.84\sin(800t-25)V$, $v_2=\cos(800t-2\pi/3)V$, $v_3= -70.71\sin(800t+\pi/6)V$. If the voltage applied across the circuit is $v_r=500\sin(800t+40)V$, find voltage across 4th impedance. (10)
 (b) Find the resistance across x and y. (10)

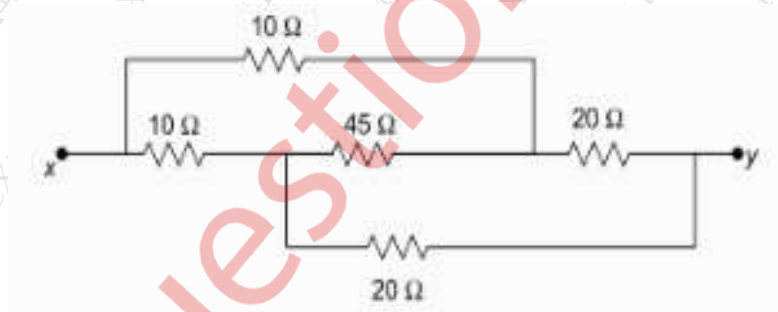

6. (a) Prove the relation between phase voltage and line voltage in a three-phase star connected system with neat phasor diagrams (10)
 (b) An alternating current of frequency 50Hz has a maximum value of 12A. (10)
 Find the following: (i) Angular frequency in radians/sec;(ii) Equation of instantaneous value of current;(iii) Value of current after 5msec; (iv) RMS value of current and (v) Time taken to reach 9.6A for the first time