

Time: 3 Hours

Max. Marks: 80

N. B. (1) Question No.1 is compulsory.**(2) Attempt any 3 questions from remaining five questions.****(3) Assume suitable data if necessary and mention the same clearly.****(4) Take $g = 9.81 \text{ m/s}^2$, unless otherwise specified.****Q1. Solve any Four-**

- a) Replace the given force system in two parallel components at B & D. (05)

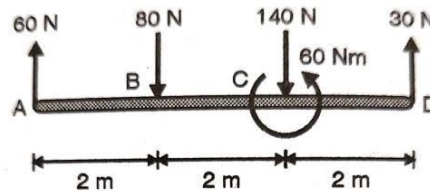

- b) The 30 kg collar may slide on frictionless vertical rod and is connected to a 34 kg counterweight. Find the value of h for which the system is in equilibrium. (05)

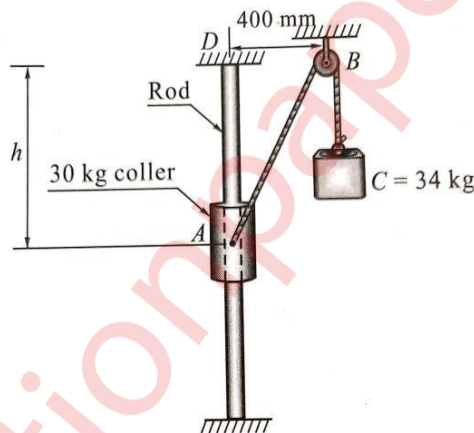

- c) A block rests on a rough inclined plane making an angle of 30° with the horizontal. The coefficient of static friction between the block and the plane is 0.8. If the frictional force on the block is 10 N, Find the mass of the block (in kg). (05)
- d) A force acts at the origin in the direction defined by the angles $\theta_y = 65^\circ$ & $\theta_z = 40^\circ$. Knowing that the x-component of the force is 750 N. Determine (i) the other components. (ii) Magnitude of the force & (iii) the value of θ_x . (05)
- e) Explain the following with example- (05)
- General Plane motion.
 - Instantaneous centre of rotation.
- f) If $x = 1 - t$ and $y = t^2$ where x and y are in meters and t is in second, determine the acceleration of the particle at $t = 3$ sec. (05)

- Q 2 Two spheres A and B of weight 1000 N and 750 N respectively are kept as shown in figure. Determine the reactions at all contact points 1,2, 3 and 4. Radius of A is 400 mm and radius of B is 300 mm (07)

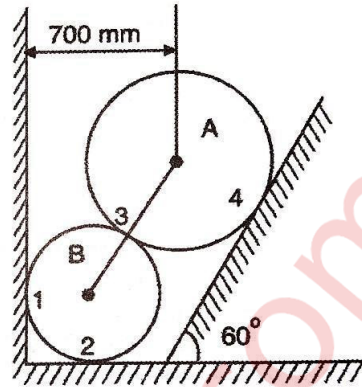

- B) Find the centroid of the shaded areas shown in the fig. (07)

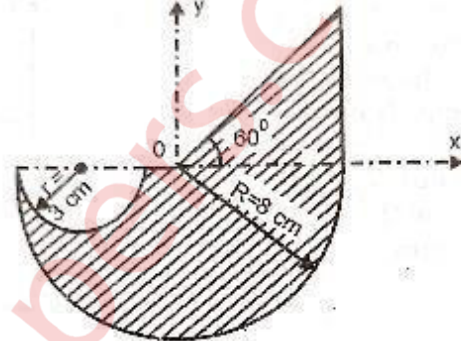

- C) A particle starts from rest from origin and its acceleration is given by

$$a = \frac{k}{(x+4)^2}$$

Knowing that $v = 4 \text{ m/s}$ when $x = 8 \text{ m}$. Find value of k , Also calculate the velocity when displacement is 10 m. (06)

- Q 3 Find the support reactions of beam loaded as shown in fig. (07)

A)

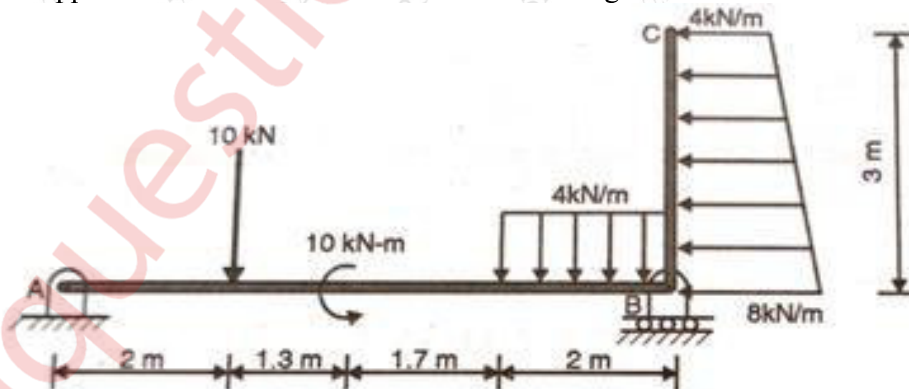

- B) A uniform ladder rests with one end against a smooth vertical wall and other end on the ground, whose coefficient of friction is 0.5. If the inclination of ladder to the ground is 50° , find the position of a man (whose weight is same as ladder) from the bottom of the ladder when the ladder is at the verge of slipping. The length of ladder is 8 m. (07)

- C) A particle moves in x-y plane with acceleration components $a_x = -3\text{m/s}^2$ and $a_y = -16\text{m/s}^2$. If its initial velocity is $V_0 = 50\text{ m/s}$ directed at 35° to the x-axis, compute the radius of curvature of the path at $t = 2\text{ sec}$. Also calculate the velocity at $t = 5\text{ Sec}$. (06)

- Q 4. A dam is subjected to three forces, 50 kN on the upstream face AB, 30 kN force on the downstream inclined face and its own weight of 120 kN as shown in figure. Determine the single force and locate its point of intersection with the base AD assuming all the forces to lie in a single plane. (07)

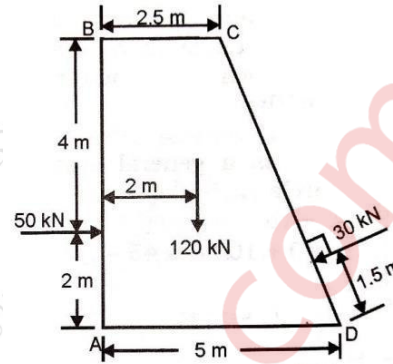

- B) A boy throws a ball so that it may clear a wall 3.6 m high. The boy is at a distance of 4.8 m from the wall. The ball was found to hit the ground at a distance of 3.6 m on the other side of the wall, Find the least velocity with which the ball can be thrown, and the corresponding angle of projection. (07)

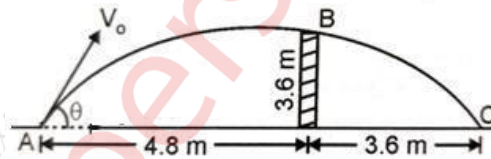

- C) For the mechanism shown in figure, the angular velocity of bar AB is 3 rad/s clockwise. Using instantaneous center of rotation, calculate the angular velocity of bar BC and the velocity of slider C for this position (06)

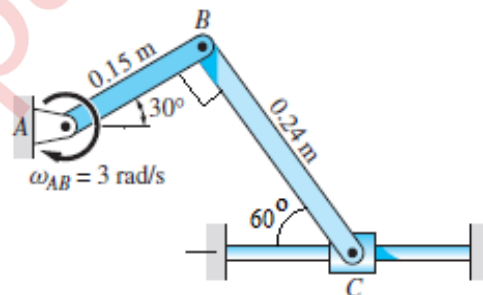

- Q 5. A tower is held in position by three cables. A) Determine position (x, y) for the cable DA so that the resultant force exerted is directed from D to O. (10)

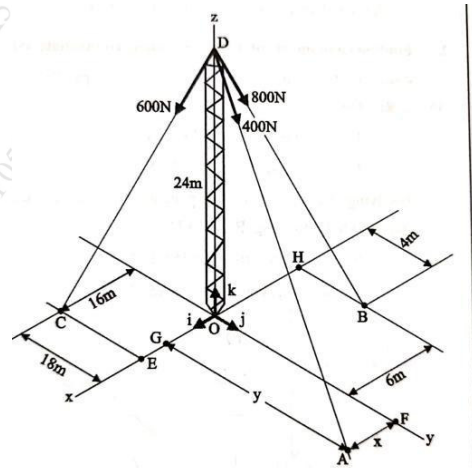

- B) Fig shows a-t curve for a particle moving along x axis what is speed & distance covered by the particle after 50 sec? Find also the maximum speed & the time at which the speed is attain by the particle, also plot v-t & x-t curve. (10)

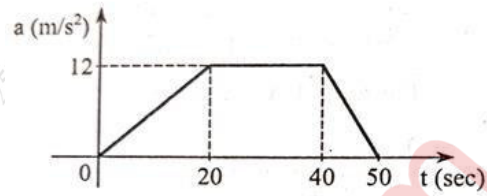

- Q 6. A block of weight 800 N is acted upon by a horizontal force P as shown in figure, if $\mu_s = 0.35$ & $\mu_k = 0.25$, determine the value of P for impending motion up the plane. (05)

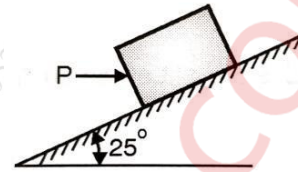

- B) A wheel of radius 0.75 m rolls without slipping on a horizontal surface. Determine the velocities of point P and Q shown in figure, when the velocity of centre of the wheel is 10 m/s towards right. (05)

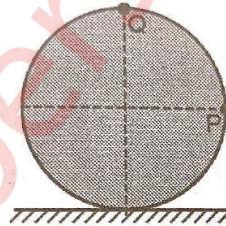

- C) A wheel of weight $W = 1000$ N rest on a smooth incline plane. It is kept from rolling down the plane by a string AC. Find the tension in the string and reaction at the point of contact D. (05)

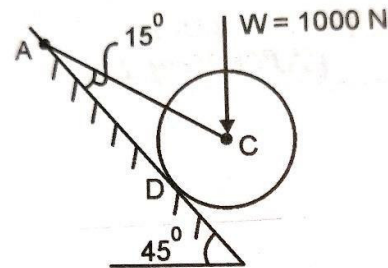

- D) A train starting from rest accelerates uniformly for 3 minutes, runs at constant speed for next 5 minutes and then come to rest in next 2 min. If it covers a total distance of 9 km, draw V- t diagram and find the acceleration and retardation in m/s^2 [05]
