

Duration: 2 hours

Marks: 60

- Note:** 1) Question No. 1 is **Compulsory**.
 2) Attempt any **THREE** questions out of the remaining FIVE.
 3) All questions carry equal marks.
 4) Figures to the right indicate full marks.

- | Q1) | Answer the following (Any five) | Marks |
|--------|---|-------|
| a) | Find the complexity of given recurrence relation using Master Method
$T(n) = 8T(n/2) + n^2$ | 03 |
| b) | Write an algorithm for Binary Search | 03 |
| c) | Explain the general method of the Greedy Approach. | 03 |
| d) | Explain the Principle of Optimality as applied to Dynamic Programming. | 03 |
| e) | Differentiate between Backtracking and Branch & Bound techniques. | 03 |
| f) | Explain the Naive String-Matching Algorithm. | 03 |
| Q2) a) | Sort the following numbers using the Selection Sort, and show the array after each pass:
28, 17, 20, 75, 13, 15 | 05 |
| b) | Write an algorithm for Merge Sort. Derive its time complexity.
Sort the following elements using Merge Sort
32, 55, 17, 48, 64, 26 | 10 |
| Q3) a) | Explain Big Theta (Θ) notation with a suitable example. | 05 |
| b) | What is Minimum Cost Spanning Tree? Write Kruskal's algorithm and state its time complexity.
Find Minimum Cost Spanning Tree for following graph using Kruskal's Algorithm | 10 |

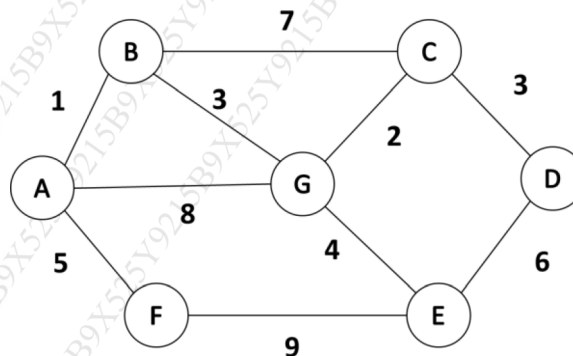

- Q4) a)** Consider a Knapsack with capacity $W = 16$. There are six items with following weights and profits. **05**
 $(P_1, P_2, P_3, P_4, P_5, P_6) = (10, 5, 15, 7, 6, 18)$
 $(W_1, W_2, W_3, W_4, W_5, W_6) = (2, 3, 5, 7, 1, 4)$
 Find the maximum profit using Fractional Knapsack algorithm
- b)** Write an algorithm to find Longest Common Subsequences between two given strings. Derive its time complexity. **10**
 Find the LCS between following strings
 $X = AVANTIKA$
 $Y = KARNAVATI$

- Q5) a)** What is Multistage Graph? Explain Forward Approach method to find optimal path in Multistage Graph. **05**
- b)** What is the N-Queen Problem? Design a backtracking algorithm to solve it. Provide step-by-step working of it using suitable example. **10**

- Q6) a)** Find the All-Pair Source Shortest path for all the vertices using Floyd-Warshall Algorithm **05**

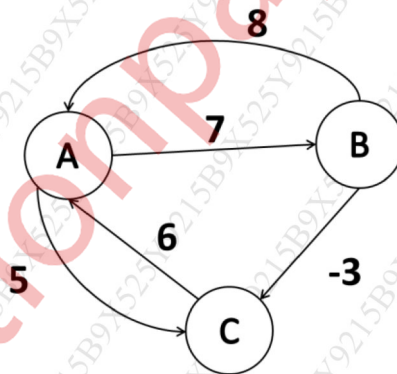

- b)** Explain Graph Coloring method with suitable example **05**
- c)** Write Rabin Karp String Matching Algorithm. State its time complexity. **05**