

Duration: 3 Hours

Total Marks: 80

- N.B. :** 1) Question Number 1 is compulsory
2) Solve any three questions from the remaining questions
3) Make suitable assumptions if needed
4) Assume appropriate data whenever required. State all assumptions clearly.

Q.1

Solve any four of the following questions.

- a. What is a tautology? Check whether the following logical expression is tautology? 5
$$[(p \rightarrow r) \wedge (\sim q \rightarrow p) \wedge \sim r] \rightarrow q$$

b. State the Pigeonhole principle and show that if any five numbers from 1 to 8 are chosen, then two of them will add to 9. 5
c. Convert the following into CNF form. 5
$$(A \rightarrow B) \rightarrow ((B \rightarrow C) \rightarrow (A \rightarrow C))$$

d. Given $S = \{1, 2, \dots, 10\}$ and a relation R on S , where $R = \{(x, y) \mid x + y = 10\}$. Is it reflexive, symmetric, transitive, antisymmetric? 5
e. Define the following terms 5
1. Planer graph 2. Cut Vertex 3.Chain 4. Monoid 5.Group

Q.2

- a. Let $A = \{p, q, r, s\}$ and let $R = \{(p, p), (p, q), (p, r), (q, p), (q, q), (r, p), (q, r), (r, q), (r, r), (s, s)\}$. Show that R is an equivalence relation. Determine the equivalence classes and find the rank of R . 8
b. Show that $A = \{0, 3, 6, 9, 12\}$ is a ring w.r.t. the operation of addition & multiplication modulo 15. 8
c. Explain two different types of Quantifiers with example? 4
Represent the following sentences using First Order logic
i) Some students took GenAI.
ii) Every student who takes GenAI passes it.

Q.3

- a. What is an Abelian Group? Let $G = \{1, 2, 3, 4, 5, 6, 7\}$ 8
i) Prepare the composition table w.r.t the operation of multiplication modulo 8.
ii) Check whether it is an Abelian group? Justify your answer.
b. Define minimum hamming distance. Find the code words generated by the parity check matrix H given below. 8

$$H = \begin{pmatrix} 1 & 0 & 1 \\ 0 & 1 & 1 \\ 1 & 1 & 0 \\ 1 & 0 & 0 \\ 0 & 1 & 0 \\ 0 & 0 & 1 \end{pmatrix}$$

c

4

Determine whether the following graph is Eulerian or Hamiltonian or both. Justify your answer.

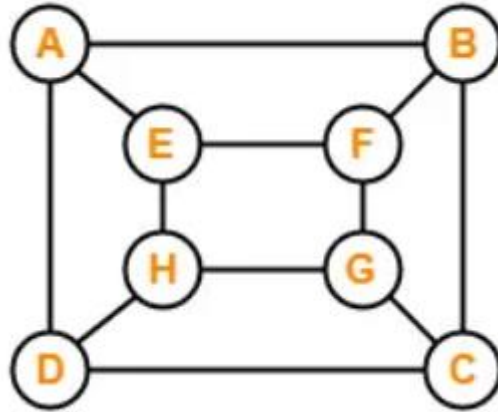

Q.4 a

Define function. What are three different types of functions.. Consider the function f and g from $N \times N$ to N given by $f(x,y) = 2x+y$ and $g(x,y) = xy$, identify its type.

8

b

Let $A = \{a,b,c,d,e\}$ and let R be a relation on A .

8

Let $R = \{(a,a), (a,c), (b,b), (c,d), (c,e), (d,a), (e,b), (e,e)\}$

Compute transitive closure using Warshall's algorithm

c

Prove using Mathematical Induction that sum of cubes of three consecutive integers is divisible by 9.

4

Q.5 a

Let $X = \{1,2,3,4,6,24,36,72\}$ and $R = \{(x,y) \in R \mid x \text{ divides } y\}$

8

i) Write the pairs in a relation set R .

ii) Construct Hasse diagram.

iii) Mention Chains and Anti Chains from above set.

iv) Is it a lattice?

b

Find the number of integers between 1 to 500 that are not divisible by 5,6, or 8?

8

c

Check whether the following graphs are Isomorphic or not? Justify

4

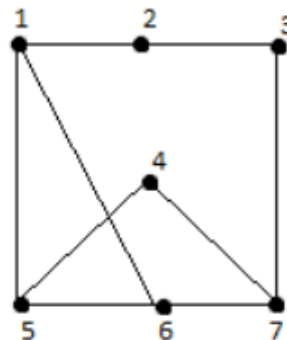
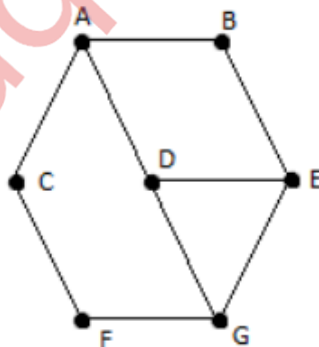

- Q.6.**
- a** Draw the Hasse Diagram of D_{72} **8**
 - i) Find the complement of each element
 - ii) Check whether it is a Distributive Lattice
 - b** Let $f(x) = x + 3$, $g(x) = x - 3$ and $h(x) = 3x$ for $x \in \mathbb{R}$, where \mathbb{R} is the set of real numbers. **8**
 - Find i) $g \circ h$ ii) $f \circ g$ i) $g \circ h \circ f$ ii) $f \circ h \circ g$
 - c** Find the generating functions for the following sequences: **4**
 - a. 0, 0, 0, 1, 2, 3, 4, 5, 6, 7,
 - b. 6, -6, 6, -6, 6, -6,
-