

Time: 3 Hours

Max Marks: 80

- N.B. 1) Question No.1 is compulsory
 2) Solve any three questions from the remaining questions.
 3) Assume suitable data if necessary.

1 Solve any four

- (a) For an NMOS device operating in saturation, plot W/L versus $V_{GS} - V_{TH}$ if
 a. I_D is constant 5
 b. g_m is constant
 (b) Find the drain current of M_4 if all transistors are in saturation 5

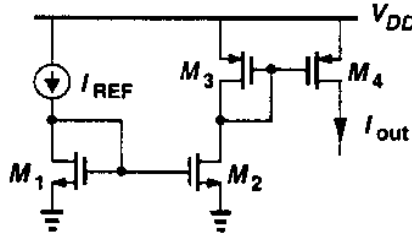

- (c) Compare full custom and semi-custom design in terms of its trade-offs and applications 5
 (d) Explain Non-ideal effects in PLL. 5
 (e) Compare various op amp topologies 5

- 2 (a) Compare common source amplifier with following loads 10
 a) NMOS diode connected load
 b) PMOS diode connected load
 c) Current source load
 d) Triode load

(b) 10

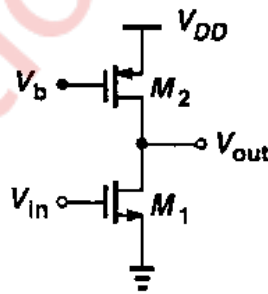

- a. Redraw the above circuit using thermal noise current source
 b. Write the expression for total output thermal noise voltage
 c. Write the expression for output thermal noise voltage referred to the gate of M_1
 d. Why should g_{m1} be maximized and g_{m2} be minimized in the above circuit.

3

Design two stage operational amplifiers that meet the following specifications

20

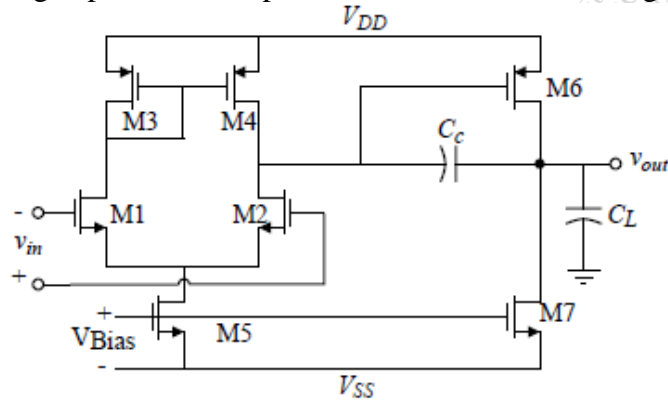

- $A_v > 3000V/V$ $V_{DD} = 2.5V$ $V_{SS} = -2.5V$
 Gain Bandwidth = 5MHz, Slew Rate $> 10V/\mu s$, 60° phase margin,
 $0.5V < V_{out} \text{ range} < 2V$,
 $ICMR = -1.25V \text{ to } 2V$,
 $P_{diss} \leq 2 \text{ mW}$, $C_L = 10pF$
 Use $K_N' = 100\mu A/V^2$, $K_P' = 20\mu A/V^2$, $V_{TN} = |V_{TP}| = 0.5V$, $\lambda_N = 0.06V^{-1}$,
 $\lambda_P = 0.08V^{-1}$, $C_{OX} = 2.47fF/\mu m^2$.
 Verify that the designed circuit meets required voltage gain and power dissipation specifications

4

- (a) Analyze following circuit to get voltage gain equation if M_2 is twice wide as that of M_1 and $V_{in1} = V_{in2}$ 20

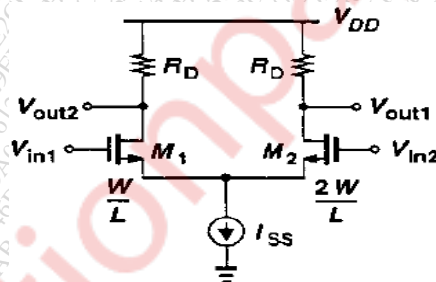

- (b) Derive the expression Voltage gain A_v and Output impedance R_o for Source follower circuit 10

5

- (a) Derive equation of differential gain, common mode gain and CMRR of a differential amplifier circuit. 10
 (b) Explain the switched capacitor amplifiers in detail with appropriate diagrams 10

6

- Write short notes on (any four)
- (a) Charge pump PLL 5
 - (b) Stability and frequency compensation of two stage Opamp 5
 - (c) Band Gap references 5
 - (d) Performance parameter of VCO 5
 - (e) AMS Design flow 5
