

Max. Marks: 80

Time: 3 Hours

Q.5D & Q.6 A are same, solve both Q.

1. Figures to the right indicate full marks.
2. Attempt any four questions including Question No.1 is compulsory.
3. Illustrate answers with sketches if required.
4. Assume any suitable data wherever necessary.



- Q.No.1. The component shown in the figure no.1 is to be sand cast. Material of the component is steel. Assuming suitable data answer the following: 20
- a). Select parting line.
  - b). Design and sketch the required pattern and core boxes.
  - c). Design the gating system.
  - d). Calculate the required size of riser using Caines's method.
  - e). Sketch the views of mold showing gating system and riser.

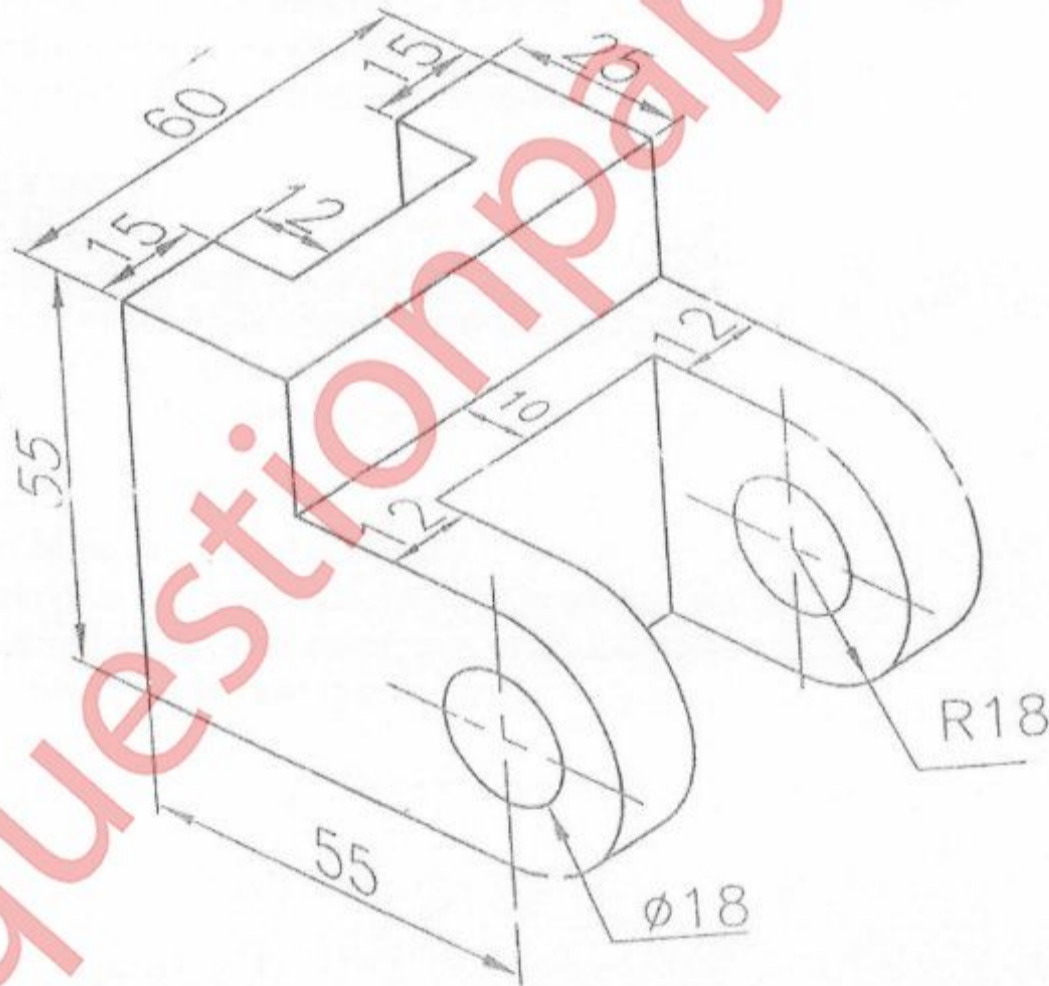

(All dimensions are in mm)

Figure 1

P.T.O.



- Q.No.2. Answer the following: 20
- Difference between Induction furnace and Electric arc furnace.
  - Explain working principle of single stroke air operated hammer.
  - Risers are placed on the top of thicker portion of the mold.
  - Explain working principle of core extrusion machine.
  - Discuss about Reho-casting process.
- Q.No.3. Give reasons for the following: 20
- Tapered sprues are used in sand mold casting process.
  - Coal dust is not used as an additive in steel sand mould casting.
  - Forgings are inherently stronger than casting.
  - Runner extension is provided in sand mold gating system.
  - Internal taper allowance provided on pattern is more than external taper allowance.
  - Flow-offs are used in pressure die casting process.
  - All corners are rounded off on the patterns
  - Pattern is larger than the casting.
- Q.No. 4. Answer the following.
- Explain Thixo casting process. 05
  - Discuss working principle of belt drop hammer. 05
  - How parting line is selected in forging dies? 05
  - What is necessary condition for biting in rolling process? 05
- Q.No. 5. Write a note on: 20
- Pattern allowance.
  - Universal rolling mill.
  - Production of seamless tubes by extrusion process.
  - Defects in forged components
  - High frequency induction furnace.
- Q.No. 6. Answer the following
- Explain defects in forged products. 05
  - How seamless tubes are manufactured in rolling process? 05
  - Define stress, strain, true stress, true strain and permeability. 05
  - Explain Shell mould casting process. 05

\*\*\*\*\*