

T.E - VI / Design of Press Tool / PROD  
& Metal Joining

26.11.15



(03 Hours)

QP Code : **6302**

[ Total Marks : 80 ]

- N.B:**
- (1) Question No. 1 is compulsory
  - (2) Attempt **any three** questions out of the remaining five questions.
  - (3) **Assume suitable data** wherever necessary.
  - (4) Figures to the right indicate full marks.

- Q.1 (a) For the component shown in Fig. 1 which is manufactured in progressive die,
- (i) Calculate economic strip layout considering size 400 mm x 1200 mm x 2 mm thick. Stock material is mild steel with 400 N/mm<sup>2</sup> shear strength. 4
  - (ii) Calculate cutting load and recommend suitable press. 4
  - (iii) Draw Sectional Front View and Top View of die showing BOM. 8

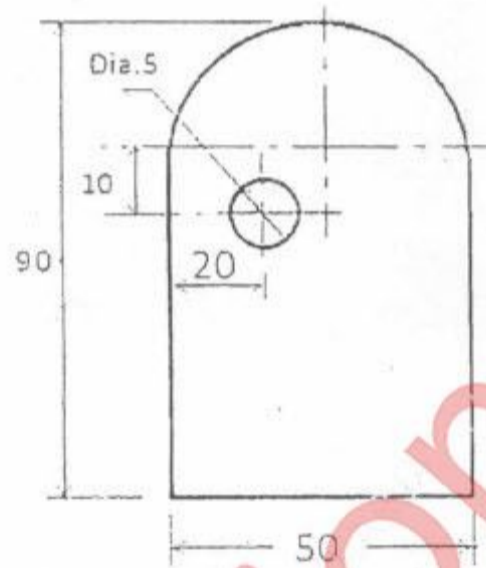

Figure 1

Note :  
All Dimensions are in 'mm'  
NOT TO SCALE

- (b) Compare TIG welding with Seam welding 4
- Q.2
- (a) Explain GMAW (MIG) welding with its advantages and limitations 6
  - (b) With the help of neat sketch, explain the terminology of press tool elements. 8
  - (c) Explain the defects in deep drawing operation. Give its remedies. 6
- Q.3
- (a) Give the design steps of Drawing dies and comment on Inter-stage annealing for multiple drawing operations. 8
  - (b) Define Welding. Classify different welding processes. 6
  - (c) Compare forming operations and cutting operations in press working 6

[Turn Over

**MD-Con.8405-15.**

- Q.4 (a) Explain the terminology of bending operation with neat labelled diagram  
What is V-Bending and Edge Bending operation? 8
- (b) Define Bending Allowance and spring-back in bending.  
Discuss methods of reducing springback. 6
- (c) Write short notes on: Materials for Press Working components and hardness. 6
- Q.5 **Differentiate the following ( any 4 )** 20
- (a) Piercing and Blanking operation.
- (b) Pressure Welding and Non-Pressure Welding
- (c) SAW welding and SMAW welding
- (d) Drawing force and Blank holding Force in Drawing operation
- (e) Blanking and Fine Blanking
- (f) OBI press and Press Brake
- Q.6 **Write Short Notes of the following (any 4)** 20
- (a) Types of Welded Joints and applications
- (b) Methods of reducing forces in press working
- (c) Shut Height of Press and die
- (d) Types of shearing dies and die-sets
- (e) Feeding mechanism of blank / stock in presses
- (f) Fixed Stripper and movable Stripper plate.
-