

PROP/CBAS/IV/TOM 10112116

Theory of Machines/01/12/16 QP CODE : 559500

(3 Hours)



Total Marks:80

NB: 1) Question No.1 is compulsory

2) Attempt any four questions out of remaining six

3) Assume suitable data wherever required

4) Figures to right indicate full marks

1 Attempt any four

20

- What is meant by inversion of a mechanism and explain any one inversion of four bar mechanism.
- Define Coriolis acceleration component and derive its expression.
- Explain Davis steering mechanism.
- What is meant by gyroscopic couple? Derive a relation for its magnitude
- In what way a mechanism differ from a machine? What is the significance of degrees of freedom of a kinematic chain when it functions as a mechanism? Give examples.

2 a) Prove that the whirling speed for a rotating shaft is the same as the frequency of natural transverse vibration. 04

- b) The mechanism of a warping machine, as shown in Fig. has the dimensions as follows: 16
 $O_1A = 100$ mm; $AC = 700$ mm ; $BC = 200$ mm ; $BD = 150$ mm ; $O_2D = 200$ mm ; $O_2E = 400$ mm ; $O_3C = 200$ mm. The crank O_1A rotates at a uniform speed of 100 rad/s. For the given configuration, determine: 1. linear velocity of the point E on the bell crank lever, 2. acceleration of the points E and B, and 3. angular acceleration of the bell crank lever

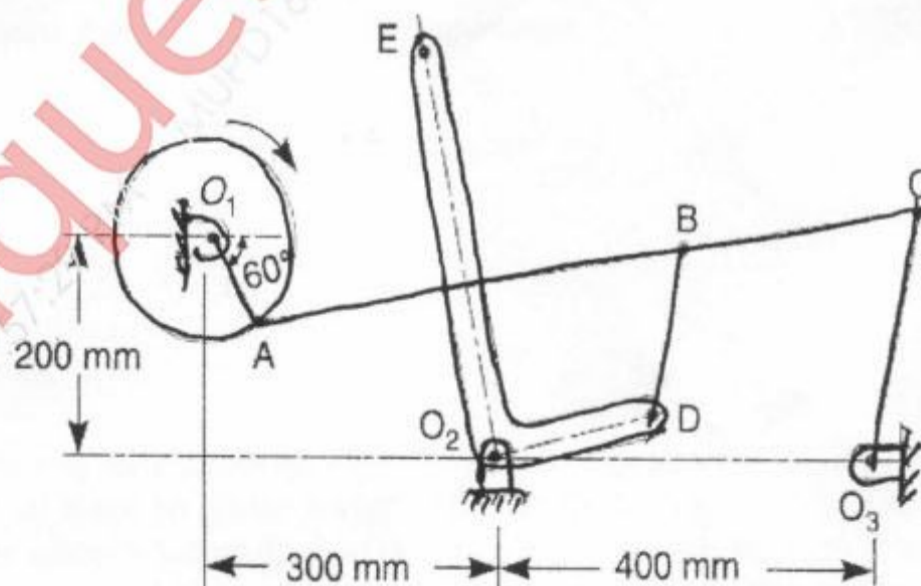

[TURN OVER

- 3 a) In a band and block brake, the band is lined with 14 blocks, each of which subtends an angle of 20° at the drum center. One end of the band is attached to the fulcrum of the brake lever and the other to a pin 150 mm from the fulcrum. Find the force required at the end of the lever 1 meter long from the fulcrum to give a torque of 4 kN-m. The diameter of the brake drum is 1 meter and the coefficient of friction between the blocks and the drum is 0.25. 10
- b) A dry single plate clutch is to be designed for an automotive vehicle whose engine is rated to give 100 kW at 2400 rpm. and maximum torque 500 N-m. The outer radius of friction plate is 25% more than the inner radius. The intensity of pressure between the plates is not to exceed 0.07 N/mm^2 . The coefficient of friction may be assumed equal to 0.3. The helical springs required by this clutch to provide axial force necessary to engage the clutch are eight. If each spring has stiffness equal to 40 N/mm , determine the initial compression in the springs and dimensions of the friction plate 10
- 4 a) A shaft carries four masses A, B, C and D of magnitude 200 kg, 300 kg, 400 kg and 200 kg respectively and revolving at radii 80 mm, 70 mm, 60 mm and 80 mm in planes measured from A at 300 mm, 400 mm and 700 mm. The angles between the cranks measured anticlockwise are A to B 45° , B to C 70° and C to D 120° . The balancing masses are to be placed in planes X and Y. The distance between the planes A and X is 100 mm, between X and Y is 400 mm and between Y and D is 200 mm. If the balancing masses revolve at a radius of 100 mm, find their magnitudes and angular positions. 10
- b) An epicyclic train of gears is arranged as shown in Fig. How many revolutions does the arm, to which the pinions B and C are attached, make: 10
 1. When A makes one revolution clockwise and D makes half a revolution anticlockwise, and
 2. When A makes one revolution clockwise and D is stationary? The number of teeth on the gears A and D are 40 and 90 respectively.

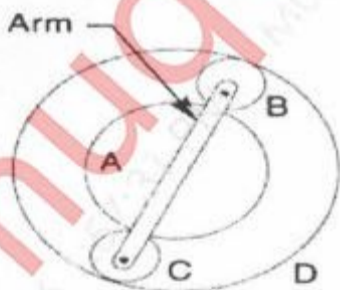

- 5 a) The following data relate to a pair of 20° involute gears in mesh: Module = 6 mm, Number of teeth on pinion = 17, Number of teeth on gear = 49; Addenda on pinion and gear wheel = 1 module. Find: 1. The number of pairs of teeth in contact is 2. The angle turned through by the pinion and the gear wheel when one pair of teeth is in contact, and 3. The ratio of sliding to rolling motion when the tip of a tooth on the 12

larger wheel (i) is just making contact, (ii) is just leaving contact with its mating tooth, and (iii) is at the pitch point.

- b) Derive the following expressions, for an uncoupled two cylinder locomotive engine : 08
(a) Swaying couple and (b) Hammer blow.
- 6 a) Construct the profile of a cam to suit the following specifications : 15
Cam shaft diameter = 40 mm ; Least radius of cam = 25 mm ; Diameter of roller = 25 mm ; Angle of lift = 120° ; Angle of fall = 150° ; Lift of the follower = 40 mm ; Number of pauses are two of equal interval between motions. During the lift, the motion is S.H.M. During the fall the motion is uniform acceleration and deceleration. The speed of the cam shaft is uniform. The line of stroke of the follower is off-set 12.5 mm from the center of the cam.
- b) A cantilever shaft 50 mm diameter and 300 mm long has a disc of mass 100 kg at its free end. The Young's modulus for the shaft material is 200 GN/m². Determine the frequency of longitudinal vibrations of the shaft. 05