

FLUID MECHANICS
(CBCGS DEC 2018)

Q1] a) An ornament weighing 36 gm in air weighs only 34 gm in water. [5]
Assuming that same copper is mixed with gold to prepare the ornament. Find the amount of copper in it. Specific gravity of gold is 19.3 and that of copper is 8.9.

Solution:-

Given,

Mass of ornament in air, $m_{\text{air}} = 36 \text{ gm}$

Mass of ornament in water, $m_{\text{water}} = 34 \text{ gm}$

Specific gravity of gold, $S_g = 19.3$

Specific gravity of copper, $S_c = 8.9$

Let;

V_c be the volume of copper and

V_g be the volume of gold

$\rho_g = 19.3 \times 1000 = 19300 \text{ kg/m}^3$

$\rho_c = 8.9 \times 1000 = 8900 \text{ kg/m}^3$

Now, $m_g + m_c = 36 \times 10^{-3}$...(i)

Loss of weight = weight of water displaced

$$= 36 \times 10^{-3} \times g - 34 \times 10^{-3} \times g$$

$$= 2 \times 10^{-3} \times g$$

$\therefore (V_g + V_c) \times \rho_w \times g = 2 \times 10^{-3} \times g$

$$\left(\frac{m_g}{19300} + \frac{m_c}{8900} \right) \times 1000 \times g = 2 \times 10^{-3} \times g$$

$$\frac{m_g}{19.3} + \frac{m_c}{8.9} = 2 \times 10^{-3} \quad \text{...(ii)}$$

Solving (i) & (ii),

$$m_g = 0.033775 \text{ kg} = 33.775 \text{ gm}$$

$$m_c = 2.225 \times 10^{-3} \text{ kg} = 2.225 \text{ gm}$$

Q1] b) Water is flowing from a hose attached to water main at 400 kPa [5] (gauge). A child places a thumb to cover most of the hose outlet, causing a thin jet of high speed water to emerge. If the hose is held vertical upward, what is maximum height that jet could achieve. Assume flow is steady, incompressible and laminar.

Solution:-

Assume the hose covered by the thumb of the child as a nozzle.

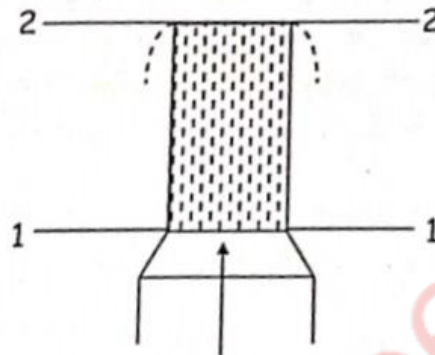

Let the hose outlet be at section 1 – 1 & maximum height of jet be at section 2 – 2.

Applying Bernoulli's theorem at 1-1 & 2-2;

$$\frac{P_1}{\rho g} + \frac{V_1^2}{2g} + Z_1 = \frac{P_2}{\rho g} + \frac{V_2^2}{2g} + Z_2$$

400 x 10³ Pa gauge pressure is acting at inlet of pipe, i.e. head available at inlet

$$= \frac{400 \times 10^3}{1000 \times 9.81} = 40.775 \text{ m}$$

$$\therefore 40.775 + 0 = 0 + 0 + Z_2$$

$$\boxed{Z_2 = 40.775 \text{ m}}$$

[Note $\frac{P_2}{\rho g} = P_{\text{atm}} = 0$ \therefore Head at 1-1 is in gauge pressure

And, velocity at maximum point will be zero.]

Q1] c) A ball falling in a lake of depth 200 m creates a decrease 0.1% in [5] its volume at the bottom. The bulk modulus of material of ball is.

Solution:-

Given, $h = 200 \text{ m}$; $dv = 0.1\%V$

$$K = \frac{dP}{\frac{dv}{V}}$$

Now, change is pressure

$$dp = \rho \cdot g \cdot h$$

$$= 1000 \times 9.81 \times 200$$

$$dp = 1.962 \times 10^6 \text{ N/m}^2$$

∴ Bulk modulus of material,

$$K = \frac{1.962 \times 10^6}{\frac{0.1 \times V}{100 \times V}}$$

$$K = 1.962 \times 10^9 \text{ N/m}^2$$

$$K = 1.962 \text{ GPa}$$

Q1]d) Explain for the boundary layer flow, whether the curve representing δ (boundary layer thickness) as a function of X over a flat plate is a stream line of flow or not.

Solution:-

A stream line may be defined as an imaginary line within the flow so that tangent at any point on it indicates the velocity at that point. Also, a stream line cannot intersect itself, nor two stream lines can cross.

Now, the curve representing δ (boundary layer thickness) as a function of X over a flat plate gives same characteristics as that of streamline.

Therefore, it is a stream line of flow.

Q1]e) Distinguish with the help of neat sketches between a [5] hydrodynamically rough surface and hydrodynamically smooth surface.

Solution:-

Hydrodynamically smooth and rough boundaries

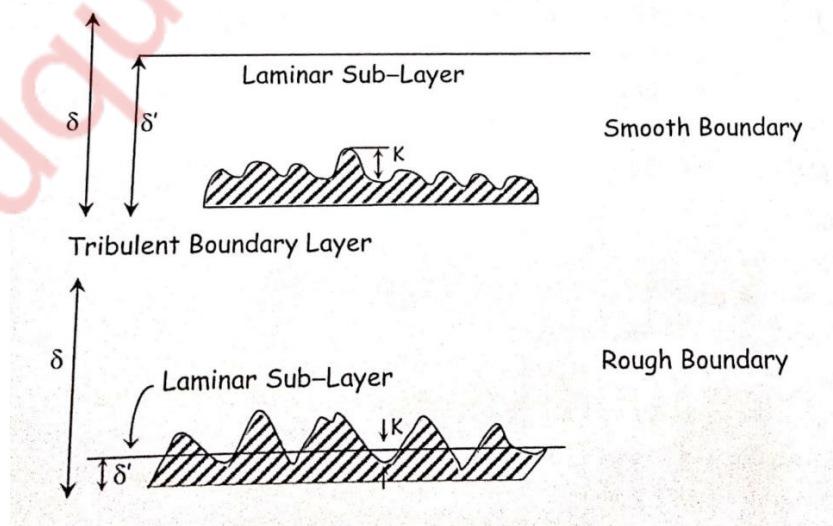

If K is the average height of the irregularities of the surface of a boundary; then the boundary is said to be rough if value of K is high and smooth if K is low. When the average height k of the irregularities is much less than the thickness of laminar sub-layer δ' , the eddies cannot reach the surface projections so the boundary acts as a smooth boundary. As the Reynolds number increases, δ' decreases and laminar sub-layer is destroyed completely. Eddies comes in contact with surface irregularities. This type of boundary is known as rough boundary.

For smooth boundary, $K/\delta' < 0.25$

For rough boundary, $K/\delta' > 6.0$

Q2] a) For the laminar boundary layer on a flat plate is

[12]

$$f(\eta) = \frac{3\eta}{2} - \frac{\eta^3}{2} \text{ where } \eta = \frac{y}{\delta} \text{ and } f(\eta) = \frac{u}{U}$$

Determine:

a) Boundary Layer Thickness

b) Local coefficient of drag

c) Check whether the flow is attached or not.

Solution:-

$$\frac{u}{U} = \frac{3}{2} \left(\frac{y}{\delta} \right) - \frac{1}{2} \left(\frac{y}{\delta} \right)^3$$

Boundary Layer thickness, δ :

$$\frac{\tau_0}{\rho U^2} = \frac{d}{dx} \left[\int_0^\delta \frac{u}{U} \left(1 - \frac{u}{U} \right) \cdot dy \right]$$

$$\frac{\tau_0}{\rho U^2} = \frac{d}{dx} \left[\int_0^\delta \left[\frac{3}{2} \left(\frac{y}{\delta} \right) - \frac{1}{2} \left(\frac{y}{\delta} \right)^3 \right] \left\{ 1 - \left[\frac{3}{2} \left(\frac{y}{\delta} \right) - \frac{1}{2} \left(\frac{y}{\delta} \right)^3 \right] \right\} \cdot dy \right]$$

$$= \frac{d}{dx} \left(\frac{39}{280} \delta \right)$$

$$\frac{\tau_0}{\rho U^2} = \frac{39}{280} \cdot \frac{d\delta}{dx}$$

$$\tau_0 = \frac{39}{280} \cdot \rho U^2 \cdot \frac{d\delta}{dx}$$

...(i)

Also, $\tau_0 = \mu \left(\frac{du}{dy} \right)_{y=0}$

$$u = U \left[\frac{3}{2} \left(\frac{y}{\delta} \right) - \frac{1}{2} \left(\frac{y}{\delta} \right)^3 \right]$$

$$\frac{du}{dy} = U \left[\frac{3}{2\delta} - \frac{3y^2}{2\delta^3} \right]$$

$$\left(\frac{du}{dy}\right)_{y=0} = \frac{3U}{2\delta}$$

$$\therefore \tau_0 = \frac{3\mu U}{2\delta}$$

...(ii)

Equating (i) & (ii)

$$\frac{39}{280} \cdot \rho U^2 \cdot \frac{d\delta}{dx} = \frac{3\mu U}{2\delta}$$

$$\delta \cdot d\delta = \frac{3}{2} \mu U \times \frac{dx}{\rho U^2} \times \frac{280}{39}$$

$$\delta \cdot d\delta = \frac{420}{39} \frac{\mu}{\rho U} dx$$

Integrating both sides, we get

$$\frac{\delta^2}{2} = \frac{420}{39} \frac{\mu}{\rho U} X$$

$$\delta = \sqrt{\frac{420 \times 2}{39} \frac{\mu X}{\rho U} \times \frac{X}{X}}$$

$$\delta = \frac{4.64x}{\sqrt{Re_n}}$$

Local co-efficient of drag, C_D^* : Now,

$$\tau_0 = \frac{3\mu U}{2\delta} \quad \& \quad \delta = \frac{4.64x}{\sqrt{Re_n}}$$

$$\tau_0 = \frac{3\mu U}{2x \frac{4.64x}{\sqrt{Re_n}}} = 0.323 \frac{\mu U}{x} \sqrt{Re_n}$$

$$\text{Also, } \tau_0 = C_D^* \cdot \frac{\rho U^2}{2}$$

$$0.323 \frac{\mu U}{x} \sqrt{Re_n} = C_D^* \cdot \frac{\rho U^2}{2}$$

$$C_D^* = 0.646 \cdot \frac{\mu U}{x} \times \sqrt{\frac{\rho U x}{\mu}} \times \frac{1}{\rho U^2}$$

$$C_D^* = \frac{0.646}{\sqrt{Re_x}}$$

Check whether flow is attached. Now,

$$\left(\frac{du}{dy}\right)_{y=0} = \frac{3U}{2\delta} > 0$$

\therefore Flow is attached i.e. flow will not separate.

Q.2] b) Air at an absolute pressure 60.0 kPa and 27°C enters a passage at [08] 486 m/s. The cross-sectional area at the entrance is 0.02 m². At section 2, further downstream, the pressure is 78.8 kPa (abs). Assuming isentropic flow, calculate the Mach number at section 2. Also Identify the type of nozzle.

Solution:-

Given, Gas – Air

Section 1 : $P_1 = 60 \text{ kPa}$, $T_1 = 27^\circ\text{C} = 300\text{K}$

$v_1 = 486 \text{ m/s}$, $A_1 = 0.02 \text{ m}^2$

Section 2 : $P_2 = 78.8 \text{ kPa}$.

For adiabatic / isentropic flow,

$$\left(\frac{\gamma}{\gamma - 1} \right) \frac{P_1}{\rho} \left\{ 1 - \left(\frac{P_2}{P_1} \right)^{\frac{\gamma - 1}{\gamma}} \right\} = \frac{V_2^2 - V_1^2}{2}$$

Now,

$$\frac{P_1}{\rho_1} = R \cdot T_1 = 287 \times 300 = 86100$$

$$\frac{P_2}{P_1} = \frac{78.8}{60} = 1.313, \quad V_1 = 486 \text{ m/s}$$

Also,
$$\frac{T_2}{T_1} = \left(\frac{P_2}{P_1} \right)^{\frac{\gamma - 1}{\gamma}}$$

$$\frac{T_2}{300} = \left(\frac{78.8}{60} \right)^{\frac{1.4 - 1}{1.4}}$$

$$T_2 = 324.3 \text{ K}$$

Now,
$$C_2 = \sqrt{\gamma \cdot R \cdot T_2}$$

$$= \sqrt{1.4 \times 287 \times 324.3}$$

$$C_2 = 360.976 \text{ m/s}$$

$$\therefore M_2 = \frac{V_2}{C_2} = \frac{432.93}{360.976}$$

$$M_2 = 1.2$$

For supersonic flow,

$$V_2 < V_1 \text{ \& } P_2 > P_1$$

\therefore It is a convergent diffuser.

Q.3] a) Use the appropriate form of Navier-Stokes equation to derive an [10] equation of velocity profile in couetter flow. State assumptions made at each stage. Plot the dimensionless velocity profile for different value of $\frac{dp}{dx}$.

Solution:-

Couetter flow :

Let us consider laminar flow between two parallel flat plates located at a distance 'b' apart such that the lower plate is at rest and the upper plate moves uniformly with a constant velocity U as shown in figure below. A small rectangular element of fluid of length dx, thickness dy & unit width is considered as a free body.

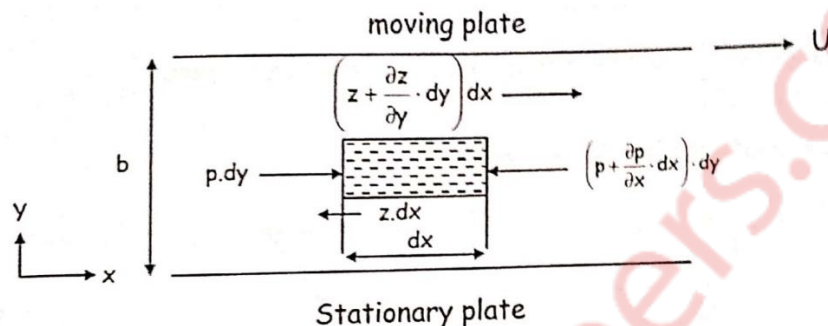

The forces acting on the fluid element are :

- (i) The pressure force, $p \cdot dy \times 1$
- (ii) The pressure force, $\left(p + \left(\frac{\partial p}{\partial x}\right) dx\right) dy \times 1$
- (iii) The shear force, $\tau \cdot dx \times 1$
- (iv) The shear force $\left(z + \left(\frac{\partial z}{\partial y}\right) dy\right) dx$

For steady and uniform flow, there is no acceleration and hence the resultant force in the direction of the flow is zero.

$$\therefore p \cdot dy - \left(p + \left(\frac{\partial p}{\partial x}\right) dx\right) dy - \tau \cdot dx + \left(z + \left(\frac{\partial z}{\partial y}\right) dy\right) dx = 0$$

$$\therefore -\left(\frac{\partial p}{\partial x}\right) dx \cdot dy + \left(\frac{\partial z}{\partial y}\right) dy \cdot dx = 0 \quad \therefore \frac{\partial p}{\partial x} = \frac{\partial z}{\partial y}$$

Thus, the pressure gradient in the direction of flow is equal to shear gradient across the flow.

According to Newton's law of viscosity,

$$\tau = \mu \frac{du}{dy}$$

$$\therefore \frac{\partial p}{\partial x} = \mu \frac{\partial^2 u}{\partial y^2}$$

Integrating above equation w.r.t.y,

$$u = \frac{1}{2\mu} \left(\frac{\partial p}{\partial x}\right) y^2 + C_1 \cdot y + C_2$$

Now at $y = 0$, $u = 0$ & at $y = b$, $u = U$

$$\therefore C_2 = 0 \quad \text{and} \quad C_1 = \frac{U}{b} - \frac{1}{2\mu} \left(\frac{\partial p}{\partial x}\right) \cdot b$$

∴ The velocity distribution for generalized couetter flow becomes,

$$u = \frac{U}{b} \cdot y - \frac{1}{2\mu} \left(\frac{\partial p}{\partial x} \right) (by - y^2)$$

Now, $\left(\frac{\partial p}{\partial x} \right)$ can be either positive, negative or zero.

Velocity profile for values of $\left(\frac{\partial p}{\partial x} \right)$

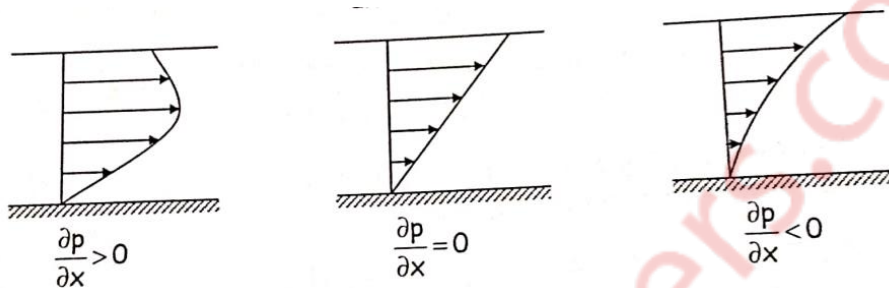

Q.3] b) In a parallel two dimensional flow in the positive x-direction the [10] velocity varies linearly from zero at $y = 0$ to 32 m/s at $y = 1$ m in perpendicular direction. Determine the expression for stream function (ψ) and plot streamline at interval $d\psi = 3 \text{ m}^2/\text{s}$. Is the flow is irrotational. Consider unit width of flow.

Solution:-

Given

$$u(y = 0\text{m}) = 0 \text{ m/s}$$

$$u(y = 1\text{m}) = 32 \text{ m/s}$$

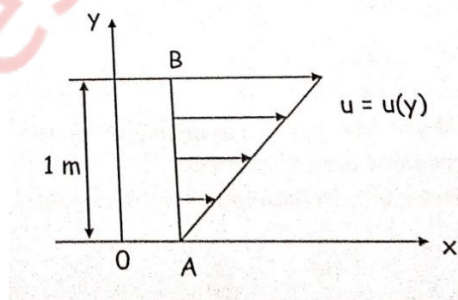

$$u = \frac{\partial \psi}{\partial y}, \quad v = - \frac{\partial \psi}{\partial x}$$

$$\text{Now, } u = u(y) = \left[\frac{32-0}{1-0} \right] \cdot y = 32y$$

$$\therefore u = 32y \text{ \& } v = 0$$

Now, $u = \frac{\partial \psi}{\partial y} = 32y$

Integrating w.r.t.y,

$$\psi = 32 \cdot \frac{y^2}{2} + \text{constant}$$

$$\therefore \psi = 16y^2 + \text{constant}$$

Stream lines – sketch

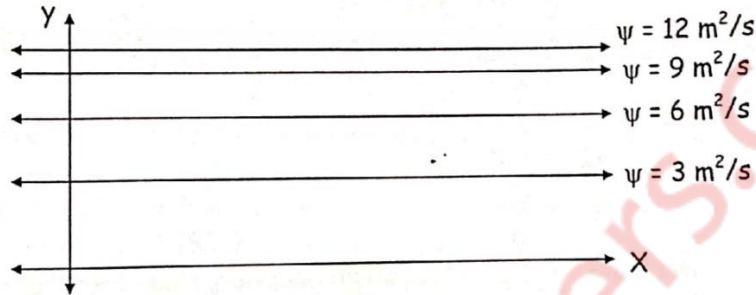

Now,

$$\frac{\partial \phi}{\partial x} = 0 \quad \& \quad \frac{\partial^2 \psi}{\partial x^2} = 0$$

$$\frac{\partial \psi}{\partial y} = 32y \quad \& \quad \frac{\partial^2 \psi}{\partial y^2} = 32$$

$$\therefore \frac{\partial^2 \psi}{\partial x^2} + \frac{\partial^2 \psi}{\partial y^2} = 0 + 32 = 32 \neq 0$$

\therefore The flow is not irrotational i.e. the flow is rotational.

Q.4] a) A pipe 0.6 m in diameter takes off water from the reservoir 150m [12] high above the datum. The pipe is 5000 m long and is laid completely at the datum level. For the last 1200 m, water is drawn by service pipe at uniform rate of 0.1 m³/sec per 300 m. Find the head lost in the last 1200 m length of pipe. Take friction factor as 0.04 and velocity is zero at dead end.

Solution:-

Given: $d = 0.6$ m, $H = 150$ m, $L = 5000$ m

For the last 1200 m which is to be analysed :

$L = 1200$ m

$Q = 0.1$ m³/s per 300 m

$F = 0.04$ (Friction Factor)

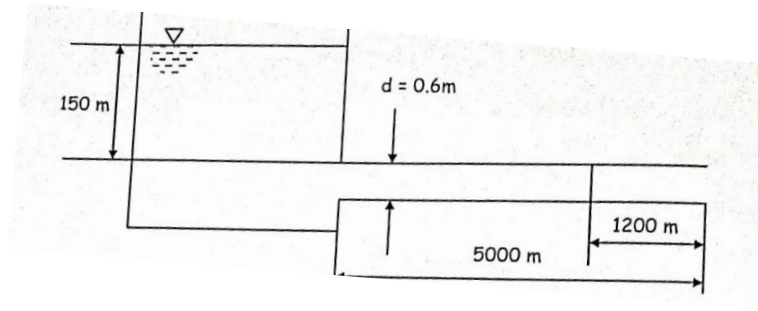

In the last 1200 m,
 $Q = 0.1 \text{ m}^3/\text{s}$ per 300 m

For 1200 m,
 $Q = 0.1 \times \frac{1200}{300} = 0.4 \text{ m}^3/\text{s}$

Also, $A = \frac{\pi}{4} \times d^2 = \frac{\pi}{4} \times (0.6)^2 = 0.2827 \text{ m}^2$

Now,

$$Q = A.V$$

$$V = \frac{Q}{A} = \frac{0.4}{0.2827} = 1.415 \text{ m/s}$$

According to Darcy- Weisbach equation, Head lost due to friction is given by,

$$h_f = \frac{4fLV^2}{2gd} = \frac{fLV^2}{2gd} = \frac{0.04 \times 1200 \times (1.415)^2}{2 \times 9.81 \times 0.6} = 8.164 \text{ m}$$

\therefore The head lost in the last 1200 m length of pipe is 8.164 m.

Q.4] b) Derive the expression for linear with angular deformation and pure rotation phenomenon in fluid flow [08]

Solution:-

Translation is linear displacement from location, say, (x_0, y_0, z_0) to (x_1, y_1, z_1) . If there are no velocity gradients at all in a flow, then a fluid element in motion will simply translate from one location to another. If there are no velocity gradients at all, then there are no accompanying stresses in the flow field. The fluid element in such a case will retain its shape. In Rotation, the orientation of the element as shown in the figure, where the sides of the element are parallel to the coordinate axes. Again there is no distortion of the element in which planes of the element that were originally perpendicular are no longer perpendicular. Volumetric deformation involves a change in shape without a

change in the orientation of the element and here, planes of the element that were originally perpendicular remain perpendicular.

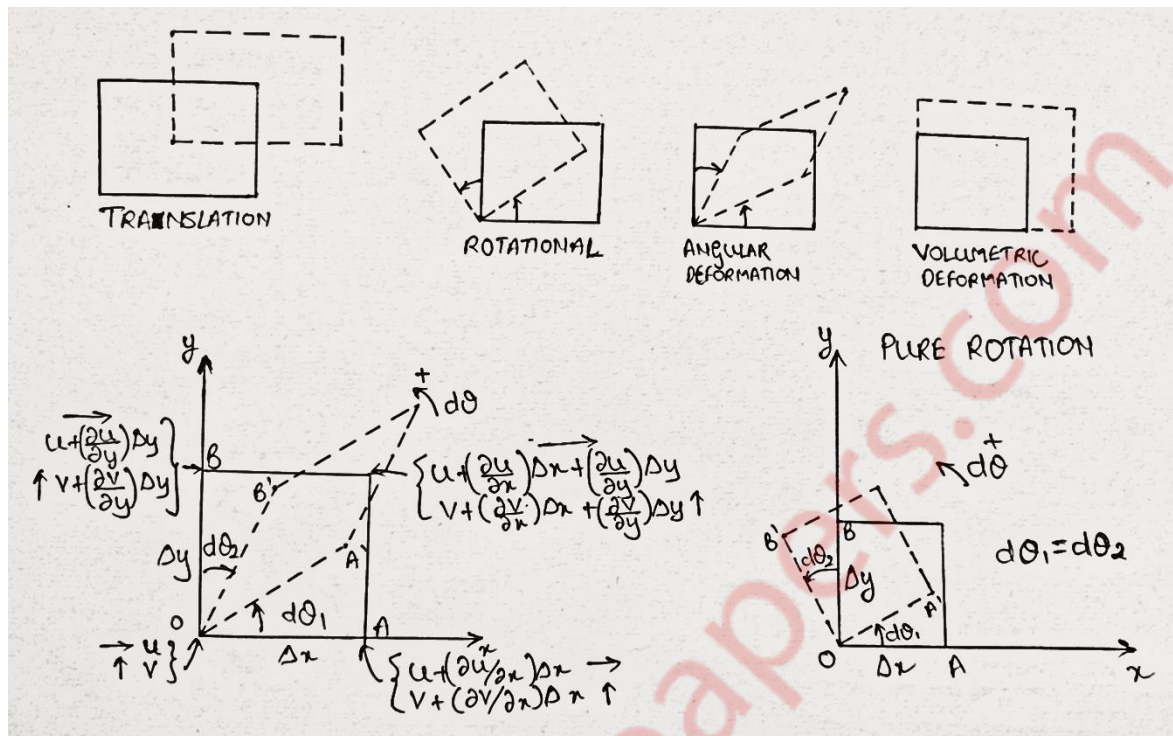

We now have to quantify these phenomena in terms of measurable flow quantities such as velocity. Eventually relate the effects of these phenomena to applied forces which cause the motion. Otherwise we cannot analytically study the flow. Translation of a fluid element is easy to understand and note. The others are not straight forward.

Rotation, Angular deformation

A fluid element may undergo rotation due the angular momentum in the flow field. For a solid body, we measure rotation by noting the angular displacement of a line on the plane of rotation from a reference. However, a fluid element is deformable and therefore to measure rotation, we choose to consider the average rotation of two lines of the element that were mutually perpendicular at the beginning of the flow. Figures (a) and (b) shows a plane fluid element of sides Δx and Δy that lies on the $x - y$ plane. Consider Figure (a). The axis of rotation is the $z -$ axis and OA and OB are the two initially perpendicular lines on the fluid element. The velocity components at O are u and v . These are increased at A and B to quantities expressible through Taylor's series and as indicated in the figure. The OA and OB shall move on to the positions OA' and OB' owing to the net velocity differences at A and B over the components at O . These constitute the angular deformation of the fluid element. Over a time dt the displacement are

$$AA' = \left(\frac{\partial v}{\partial x} \Delta x\right)dt, \quad BB' = \left(\frac{\partial u}{\partial y} \Delta y\right)dt$$

The corresponding angles of deformation per unit time are obtained by dividing the respective arm lengths. Therefore,

$$\begin{aligned} d\dot{\theta}_1 &= \lim_{dt \rightarrow 0} \frac{d\theta_1}{dt} = \lim_{dt \rightarrow 0} \frac{AA'/\Delta x}{dt} = \lim_{dt \rightarrow 0} \frac{\left(\frac{\partial v}{\partial x} \Delta x\right)dt}{\Delta x dt} \\ &= \frac{\partial v}{\partial x} \text{ (anti-clockwise)} \end{aligned}$$

Similarly,

$$d\dot{\theta}_2 = \frac{\partial u}{\partial y} \text{ (clockwise)}$$

We now adopt a convention. Anticlockwise rotation is positive. The average angular velocity of the fluid element about the z-axis in Figure (a) is

$$w_z = \frac{1}{2} (d\dot{\theta}_1 + d\dot{\theta}_2) = \frac{1}{2} \left(\frac{\partial v}{\partial x} - \frac{\partial u}{\partial y} \right)$$

For a three dimensional element, the rotations about the x and y axis are similarly obtained as, and we list the three as:

$$w_z = \frac{1}{2} \left(\frac{\partial v}{\partial x} - \frac{\partial u}{\partial y} \right), \quad w_x = \frac{1}{2} \left(\frac{\partial w}{\partial y} - \frac{\partial v}{\partial z} \right), \quad w_y = \frac{1}{2} \left(\frac{\partial u}{\partial z} - \frac{\partial w}{\partial x} \right)$$

and $w = w_x i + w_y j + w_z k$

In pure rotation, the fluid element, as shown in Figure (b), will rotate about the z axis as an undeformed element such that $d\dot{\theta}_1 = d\dot{\theta}_2$ (Forced vertex).

But for pure rotation, $d\dot{\theta}_2 = -\frac{\partial u}{\partial y}$ and it is anticlockwise. Therefore, for pure

rotation, $\frac{\partial v}{\partial x} = -\frac{\partial u}{\partial y}$ and $w_z = \frac{\partial v}{\partial x} = -\frac{\partial u}{\partial y}$. Next, let us look at general angular

deformation. We see from the figure (a), that, in addition to the rotation associated with derivatives $\frac{\partial u}{\partial y}$ and $\frac{\partial v}{\partial x}$, these derivatives may also cause the

element to undergo an angular deformation and hence a change in shape. The change in the right angle formed by the lines OA and OB due to such angular deformation, $(d\dot{\theta}_1 - d\dot{\theta}_2)$, is called the shearing strain in the x-y plane $\dot{\gamma}_{xy}$.

The rate of angular deformation is the rate of decrease the angle between lines OA and OB. $(d\dot{\theta}_1 - d\dot{\theta}_2)$ is called the rate of shearing strain or the rate of regular deformation $\dot{\gamma}_{xy}$. Thus

$$\dot{\gamma}_{xy} = \left(\frac{\partial v}{\partial x} + \frac{\partial u}{\partial y} \right) = \epsilon_{xy} = \epsilon_{yx}$$

Where the ϵ notation has been included since many people use that instead of $\dot{\gamma}$ to denote rate of shearing strain. Similarly,

$$\dot{\gamma}_{yz} = \left(\frac{\partial w}{\partial y} + \frac{\partial v}{\partial z} \right) = \epsilon_{yz} = \epsilon_{zy}$$

$$\dot{\gamma}_{zx} = \left(\frac{\partial u}{\partial z} + \frac{\partial w}{\partial x} \right) = \epsilon_{zx} = \epsilon_{xz}$$

We see that angular deformations are associated with shear strain rates. We would expect the shear strain rates to arise as a result of shear stresses. Clearly, the rate of shearing strain is seen to be zero for pure rotation (for example, solid body rotation).

Q.5] Using Reynold's Transport Theorem derive the mass flow rate equation and momentum equation to solve the following [06]

Water at a pressure of 72 kN/m² flows through a horizontal pipe of diameter 360 mm at the rate of 300 lps. The direction of water is changed through 120° by a vertical bend whose exit diameter is 240 mm. The volume of the bend is 0.14 m³. The exit of the bend is 2.4 m above the inlet. Find the magnitude and direction of the resultant force on the bend due to water. Neglect friction and minor losses. [14]

Solution:

Mass flow rate equation (continuity equation):

According to Reynold's Transport Theorem,

$$\frac{dB_{\text{sys}}}{dt} = \frac{d}{dt} \int_{C.V.} \rho b \, dv + \int_{C.S.} \rho b (\bar{V} \cdot \hat{n}) \, dA$$

Replacing 'B' by mass 'm' and 'b' by 1,

$$\frac{dm_{\text{sys}}}{dt} = \frac{d}{dt} \int_{C.V.} \rho \, dv + \int_{C.S.} \rho (\bar{V} \cdot \hat{n}) \, dA$$

Now, $\frac{dm_{\text{sys}}}{dt} = 0$

$$\therefore 0 = \frac{d}{dt} \int_{C.V.} \rho \, dv + \int_{C.S.} \rho (\bar{V} \cdot \hat{n}) \, dA$$

For steady flow,

$$\sum_{\text{out}} m = \sum_{\text{in}} m$$

$$\rho_1 A_1 V_1 = \rho_2 A_2 V_2$$

For incompressible fluid, $\rho = \text{constant}$

$$\therefore A_1 V_1 = A_2 V_2$$

Momentum equation:

According to Reynold's Transport Theorem,

$$\sum F = \frac{d}{dt} \int_{C.V.} \rho \bar{V} \, dv + \int_{C.S.} \rho \bar{V} (\bar{V} \cdot \hat{n}) \, dA$$

For steady, one-dimensional flow,

$$\sum F = \sum_{\text{out}} m - \sum_{\text{in}} m$$

$$\sum F = m(V_2 - V_1)$$

Given, $P_1 = 72 \text{ kN/m}^2$ $d_1 = 360 \text{ mm} = 0.36 \text{ m}$

$Q = 300 \text{ lps} = 0.3 \text{ m}^3/\text{s}$ $d_2 = 240 \text{ mm} = 0.24 \text{ m}$

Volume of bend = 0.14 m^3

$z_2 - z_1 = 2.4$

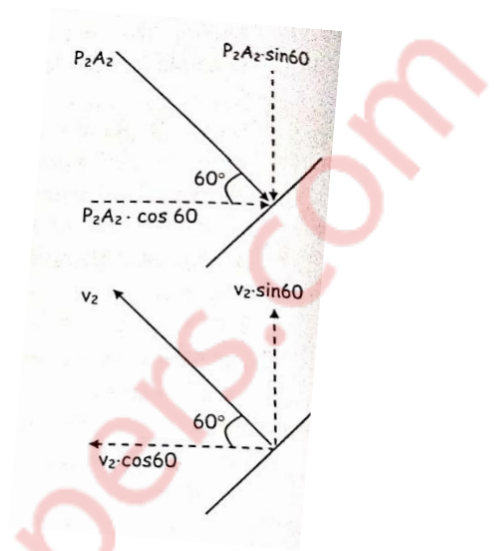
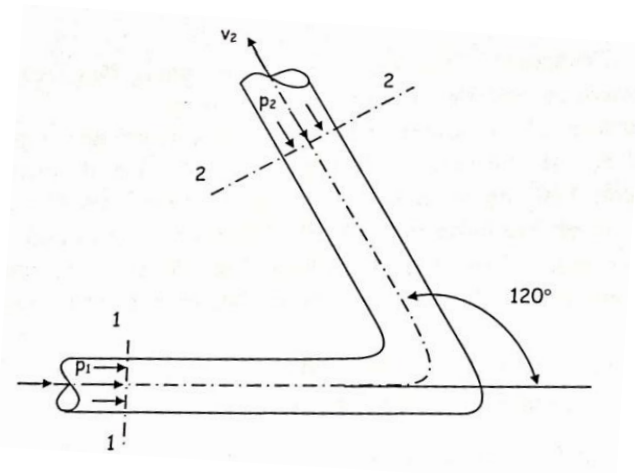

$$A_1 = \frac{\pi}{4} d_1^2 = \frac{\pi}{4} \times (0.36)^2 = 0.1018 \text{ m}^2$$

$$A_2 = \frac{\pi}{4} d_2^2 = \frac{\pi}{4} \times (0.24)^2 = 0.04524 \text{ m}^2$$

$$V_1 = Q/A_1 = 0.3/0.1018$$

$$V_1 = 2.95 \text{ m/s}$$

$$V_2 = Q/A_2 = 0.3/0.04524$$

$$V_2 = 6.63 \text{ m/s}$$

Applying Bernoulli's equation to section 1 – 1 & 2 – 2, we get

$$\frac{P_1}{\rho g} + \frac{V_1^2}{2g} + z_1 = \frac{P_2}{\rho g} + \frac{V_2^2}{2g} + z_2$$

$$\frac{72 \times 10^3}{1000 \times 9.81} + \frac{(2.95)^2}{2 \times 9.81} = \frac{P_2}{1000 \times 9.81} + \frac{(6.63)^2}{2 \times 9.81} + 2.4$$

$$P_2 = 30.83 \times 10^3 \text{ N/m}^2$$

Force along X – axis,

$$f_x = \rho Q[V_1 - (-V_2 \cos 60)] + P_1 A_1 + P_2 A_2 \cos 60$$

$$= 1000 \times 0.3 \times [2.95 + 6.63 \cdot \cos 60] + 72 \times 10^3 \times 0.1018$$

$$+ 30.83 \times 10^3 \times 0.04524 \times \cos 60$$

$$f_x = 9.91 \times 10^3 \text{ N} = 9.91 \text{ kN} (\rightarrow)$$

Force along Y-axis,

$$f_y = \rho Q[0 - V_2 \cdot \sin 60] - P_2 A_2 \cdot \sin 60 - \text{weight of water in bend}$$

$$\text{weight of water in bend} = \rho \cdot g \times \text{volume of bend}$$

$$= 1000 \times 9.81 \times 0.14$$

$$= 1373.4 \text{ N}$$

$$f_y = 1000 \times 0.3 [-6.63 \cdot \sin 60] - 30.83 \times 10^3 \times 0.04524 \times \sin 60 - 1373.4$$

$$f_y = -4.304 \times 10^3 \text{ N} = -4.304 \text{ kN}$$

$$= 4.304 \text{ kN } (\downarrow)$$

Magnitude of resultant force acting on the bend,

$$f_R = \sqrt{F_x^2 + F_y^2} = \sqrt{(9.91)^2 + (4.304)^2}$$

$$= 10.804 \text{ kN}$$

Direction of resultant force with X – axis,

$$\tan \theta = \frac{f_y}{f_x} = \frac{4.304}{9.91}$$

$$\therefore \theta = 23.47^\circ$$

Q.6] Write short note for the following

Q.6] (a) Write short note for Moody's diagram

Solution

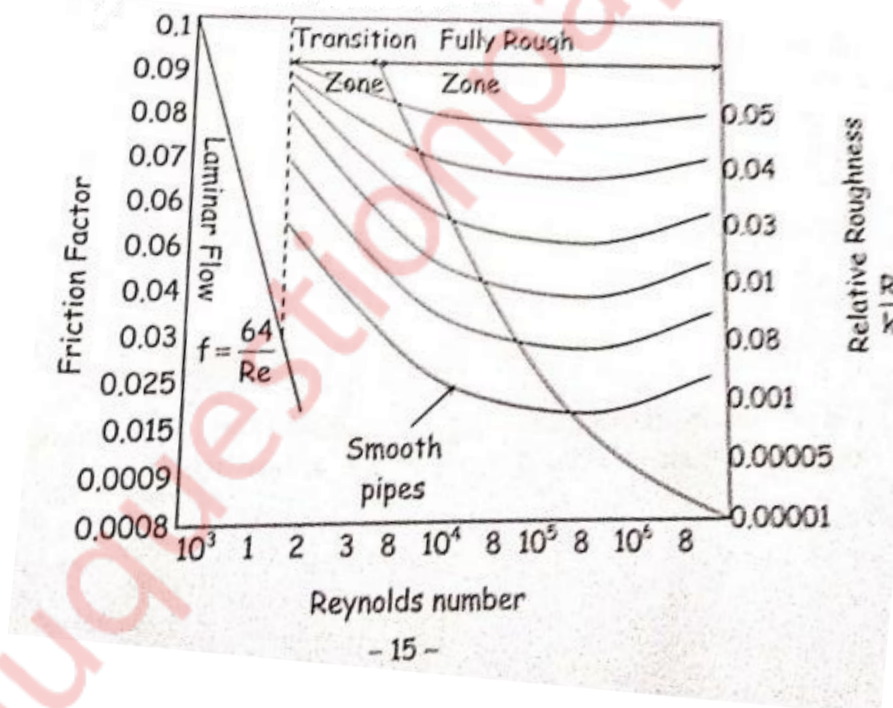

L.F. Moody's diagram is a graph plotted to find Darcy – Weisbach friction factor for a commercial pipe. The diagram plotted is the form of frictional factor versus Reynold's number Re and curves for various values of relative roughness (R/K).

Moody has plotted curve for equation,

$$\frac{1}{\sqrt{f}} = 2 \log_{10} \left(\frac{R}{K} \right) = 1.74 - 2 \log_{10} \left(1 + 18.7 \frac{R/K}{Re \sqrt{f}} \right)$$

Which helps to determine friction factor 'f' from the curve if the numerical values of R/K & Re of flow is known.

The value of equivalent sand grain roughness[k] depends on condition of material. As the pipe becomes older, the roughness increases due to corrosion.

Q.6] (b) Write short note for Induced drag on aerofoil

[05]

Solution:

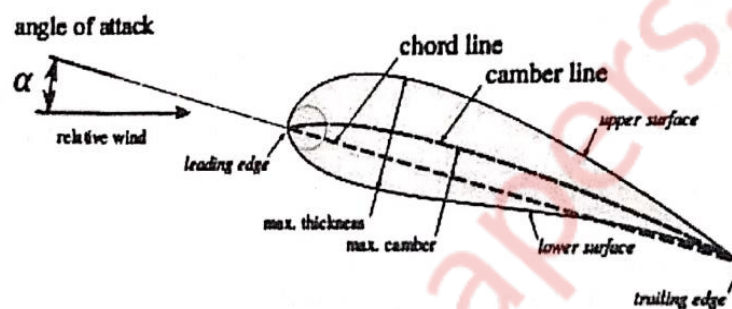

In aerodynamics, induced drag is an aerodynamic force that occurs whenever a moving object redirects the airflow coming at it. This drag force occurs in airplanes due to wings or a lifting body redirecting air to cause lift and also in cars with aerofoil wings that redirect air to cause a down force.

For an aerofoil, co-efficient of lift depends upon, the angle of attack (α).

$$C_L = 2\pi \cdot \sin\alpha$$

As we go on increasing α , co-efficient of lift also goes on increasing. The angle of attack corresponding to maximum C_L is called stalling angle.

Experimentally, it was found that if the angle of attack is increased beyond the stalling angle, it will result in decrease in coefficient of lift

**Q.6] (c) Write short note for Stream function and velocity potential [05]
function and their importance in ideal fluid flow theory.**

Solution:

Velocity potential function (ϕ) :

It is defined as scalar function of space and time such that its negative derivative with respect to any direction gives the fluid velocity in that direction.

$$u = -\frac{\partial\phi}{\partial x}, \quad v = -\frac{\partial\phi}{\partial y}, \quad w = -\frac{\partial\phi}{\partial z}$$

Importance of ϕ :

- i. If velocity potential (ϕ) exists, the flow should be irrotational.
- ii. If velocity potential (ϕ) satisfies the Laplace equation, it represents the possible steady incompressible irrotational flow.

Stream function (ψ) :

It is defined as the scalar function of space & line, such that its partial derivative with respect to any direction gives velocity component at right angles to that direction.

$$\frac{d\psi}{dx} = v, \quad \frac{d\psi}{dy} = -u$$

Importance of ψ :

- i. If stream function exists, it is a possible case of fluid flow which may be rotational or irrotational.
- ii. If stream function (ψ) satisfies Laplace equation, it is an irrotational flow.

**Q.6] (d) Write short note for Conditions of equilibrium for floating and [05]
submerged bodies.**

Solution:

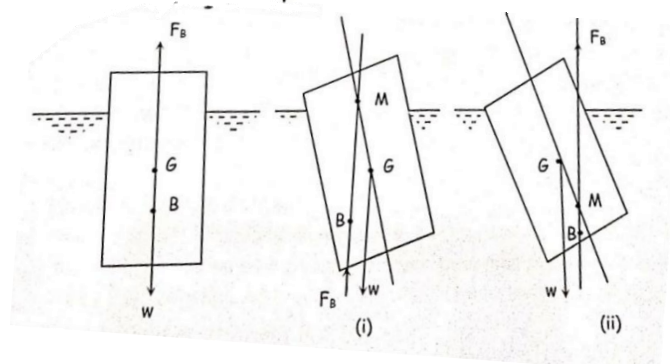

The stability of a floating body is determined from the position of Meta-Centre (M). In case of floating body, the weight of the body is equal to the weight of liquid displaced.

- Stable equilibrium : If the point M is above G, the floating body will be in stable equilibrium as shown in fig.(i)
- Unstable equilibrium : If the point M is below G, the floating body will be in unstable equilibrium as shown in fig.(ii)
- Neutral equilibrium : If the point M is at the centre of gravity (G) of the body, the floating body will be in neutral equilibrium.

Condition of equilibrium or submerged

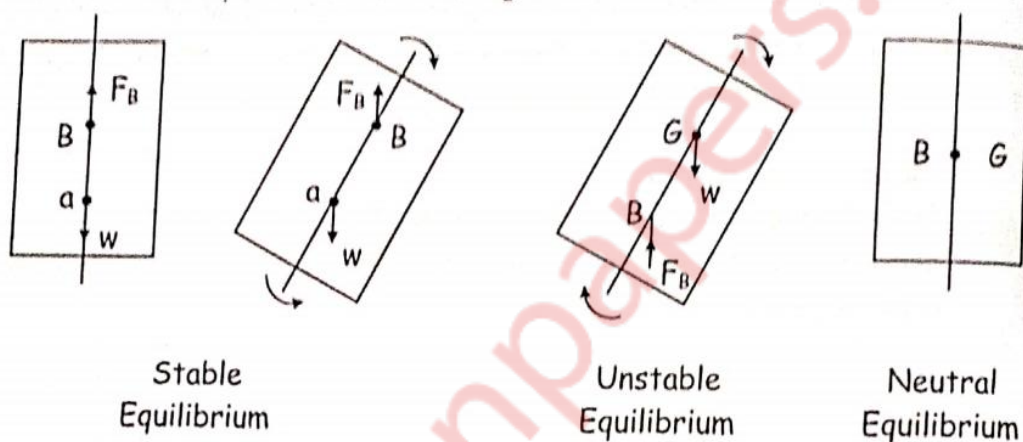

- Stable equilibrium : If $F_B = W$ and point B is above G, the body is said to be in stable equilibrium.
- Unstable equilibrium : If $F_B = W$, but the centre of buoyancy (B) is below centre of gravity (G), the body is in unstable equilibrium.
- Neutral Equilibrium : if $F_B = W$ and B and G are at same point, the body is in neutral equilibrium.