

PRODUCTION PROCESS I

(MAY 2019)

Q1. Attempt the following two questions:

(a) Classify production process in details.

(10)

SOLUTION:

There are 4 different types of productions which are most commonly used. Which type of production should be used by the company depends on the type of product being manufactured, the demand of the product as well as the supply of raw materials. Taking these factors into consideration, below are the 4 types of Production.

1) Unit or Job type of production

This type of production is most commonly observed when you produce one single unit of a product. A typical example of the same will be tailored outfits which are made just for you or a cake which is made just like you want it.

Example of Unit type of production

It is one of the most common types of products used because it is generally used by small businesses like restaurants, individual products providers or individual services providers.

2) Batch type of Production

It is one of the types of production most commonly used in consumer durables, FMCG or other such industries where there are large varieties of products with variable demands. Batch production takes place in batches. The manufacturer already knows the number of units he needs to a manufacturer and they are manufactured in one batch.

So, if a manufacturer has the shortage of Product X and 100 units of this product are consumed in one month, then the manufacturer can give orders for batch production of 100 units of Product X.

3) Mass Production or Flow production

One of the best examples of mass production is the manufacturing process adopted by Ford. Mass production is also known as flow production or assembly line production. It is one of the most common types of products used in the automobile industry and is also used in industries where continuous production is required.

Assembly line or mass production plants typically focus on specialization. There are multiple workstations installed and the assembly line goes through all the workstations turn by turn. The work

is done in a specialized manner and each workstation is responsible for one single type of work. As a result, these workstations are very efficient and production due to which the whole assembly line becomes productive and efficient.

4) Continuous production or Process production

There is a lot of confusion between mass production and continuous production. It can be differentiated by a single element. The amount of mechanical work involved. In Mass production, both machines and humans work in tandem. However, in continuous production, most of the work is done by machines rather than humans. In continuous production, the production is continuous, 24x7 hours, all days in a year.

(b) Compare wood and metal as pattern materials. (10)

SOLUTION:

Sr. no.	wood	Metal
1	These are used where the no. of casting to be produced is small and pattern size is large.	These are employed where large no of casting have to be produced for same patterns.
2	The material used for casting is wood.	The material used is metals.
3	Inexpensive	Very expensive
4	Easily available in large quantities	Available in small quantities.
5	Easy to fabricate	Very hard to fabricate
6	Light in weight	Heavy due to weight of metals.
7	They can be repaired easily	They require high skilled laborers to repair and are difficult.
8	Easy to obtain good surface finish	Accurate and smooth surface finish.
9	Poor wear and tear resistance.	Do not warp, retain their shape
10	Life is very short	Possess much longer life
11	Common used wood for patterns are: Teak, pine, mahogany, deodar etc.	Common used metal for patterns are: Cast iron, aluminum and its alloys, steels, white metal, brass etc.

Q2. Attempt the following two questions:

(a) Describe the CO₂ shell moulding process. (10)

SOLUTION:

Co₂ Casting is a kind of sand casting process. In this process the sand molding mixture is hardened by blowing gas over over the mold. This process is favoured by hobby metal casters because a lot of cost cutting can be done. In addition, one can be sure of getting dimensionally

accurate castings with fine surface finish. But, this process is not economical than green sand casting process.

Process:

The principal of working of the CO₂ process is based on the fact that if CO₂ gas is passed through a sand mixture containing sodium silicate, the sand immediately becomes extremely strongly bonded as the sodium silicate becomes a stiff gel. This gel is responsible for giving the necessary strength to the mould. The chemical reaction can be represented as:

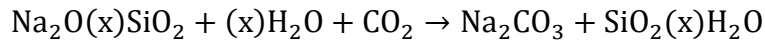

Where x is 3, 4 or 5.

The sand used for this process must be dry with a maximum moisture content of 0.25% and free of clay. This sand is mixed thoroughly with 3 to 5 % sodium silicate liquid base binder in a Muller for about 4 to 5 minutes. Suitable additives such as coal powder, wood flour, sea coal, and dextrin may be added to improve properties like collapsibility. The suitable sand mixture can then be packed around the pattern in the flask or in the core box by standard machines, core blowers, or by hands.

When the packing is complete, CO₂ is forced into the mould or core at a pressure of about 142kN/m². For predetermined length of time. The reaction proceeds rapidly in the early stage of gasification and the compressive strength of the sand mixture reaches the maximum value when a certain critical amount of gas is passed. The time to harden a small or medium sized body of sand will range from 15 to 20 minutes.

The hardness of mould is further increased by exposing them to free atmosphere for a short while after gassing.

Patterns used in this process may be metals or plastic.

Applications: Co₂ casting process is ideal where speed and flexibility is the prime requirement. Molds and cores of a varied sizes and shapes can be molded by this process.

Advantages: This process has many advantages in comparison to other forms of castings some of them are as follows:

- Compared to other casting methods cores and molds are strong
 - Reduces fuel cost since gas is used instead of to other costly heating generating elements
 - Reduces large requirement for number of mold boxes and core dryers
 - Provides great dimensional tolerance and accuracy in production
 - Moisture is completely eliminated from the molding sand
 - This process can be fully automated.
-

(b) Differentiate between MIG welding and TIG welding.

(10)

SOLUTION:

Sr. No.	TIG	MIG
1	No consumable electrodes are used.	Consumable electrodes are used.
2	Electrodes are used of tungsten or tungsten alloys.	Bare welding wire is made of desired composition.
3	Electrode only generates an arc and does not melt.	Electrode generates an arc and melts also.
4	Easier for thin plates and small parts.	Widely used for thick plates (above 4mm).
5	Welding torch is water cooled.	Welding torch is air or water cooled.
6	Used for joining dissimilar metals.	Used for joining similar metals.
7	It is a slow process.	It is a faster process.
8	During the process, separate filler material is used.	In this process, metal electrode will act as a filler material.
9	Cost of equipment is lower than MIG.	Cost of equipment is high.

Q3. Attempt the following two questions:

(a) Describe rolling process in general with a neat labeled sketch. (10)

SOLUTION:

The process of shaping metals into semi-finished or finished forms by passing between rollers is called rolling. Rolling is the most widely used metal forming process. It is employed to convert metal ingots to simple stock members like blooms, billets, slabs, sheets, plates, strips etc.

In rolling, the metal is plastically deformed by passing it between rollers rotating in opposite direction. The main objective of rolling is to decrease the thickness of the metal. Ordinarily, there is negligible increase in width, so that the decrease in thickness results in an increase in length.

Rolling is done both hot and cold. It is accomplished in rolling mills. A rolling mill is a complex machine having two or more working rollers, supporting rollers, roll stands, drive motor, reducing gear, flywheel, coupling gear etc.

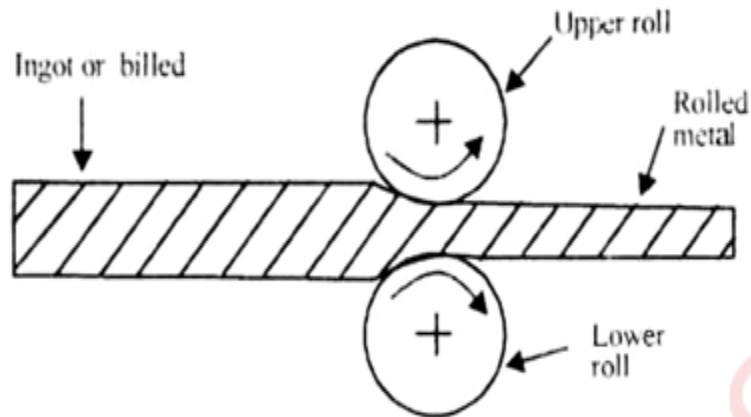

Rollers may be plain or grooved depends upon the shape of rolled product. The metal changes its shape gradually during the period in which it is in contact with the two rollers. The range of products that can be produced by rolling is very large. Rolling is a more economical method of deformation than forging when metal is required in long lengths of uniform cross-section. It is one of the most widely used among all the metal working processes, because of its higher productivity and lower cost. The materials commonly rolled are steel, copper, magnesium, aluminum and their alloys.

Principles of Rolling:

The rolling is a process which consists of passing the metal through a gap between rollers rotating in opposite direction. This gap is smaller than the thickness of the part being worked.

Therefore, the rollers compress the metal while simultaneously shifting it forward because of the friction at the roller-metal interfaces. When the work piece completely passes through the gap between the rollers, it is considered fully worked.

As a result, the thickness of the work is decreases while its length and width increases. However, the increase in width is insignificant and is usually neglected.

The Figure shows the simple rolling operation of a plate. The decrease in thickness is called draft, whereas the increase in length is termed as absolute elongation. The increase in width is known as absolute spread.

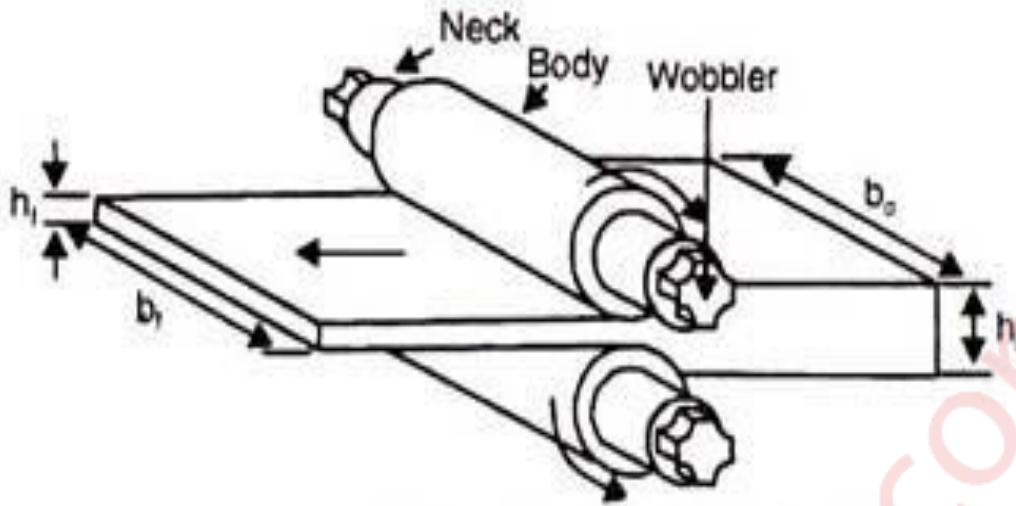

(b) Compare drop forging with hammer forging process.

(10)

SOLUTION:

Sr. no.	Press forging	Drop forging
1	Press forging is a method of forging that involves the slow and continuous pressure on the work piece.	A metal forming process that, a billet is inserted into a die and then hammered until it has assumed the shape of the die
2	Press forging has maximum peak force between 30 to 100 ms.	Drop hammers reach peak loads in 2-5 ms
3	Automation is possible in case of press forging	drop hammers employ operators and are not automatized
4	Press forging employ operators and are not automatized	Drop forging are less safe compared
5	Less prone to problems from operators and variability in the product	more prone to problems from operators and variabilities in the product
6	Press forging is less effective in breaking large internal inclusions	drop forging is very effective in breaking large internal inclusions
7	Initial cost is higher	Initial cost is lower
8	Process is faster and has higher production rate	Process is relatively slow and has moderate production rate.
9	High skilled labour required for performing operations.	Semi skilled or unskilled labour can do the task.
10	Process can be dangerous if procedure is not followed	Process is harmless.

Q4. Attempt the following two questions:

(a) Describe the blow moulding process for plastics.

(10)

SOLUTION:

Blow molding is the process of forming a molten tube (referred to as the parison or preform) of thermoplastic material (polymer or resin) and placing the parison or preform within a mold cavity and inflating the tube with compressed air, to take the shape of the cavity and cool the part before removing from the mold.

Any hollow thermoplastic part can be blow molded.

Parts are not just limited to bottles, where there is one opening and it is usually smaller in diameter or size than the overall body dimensions. These are some of the most common shapes used in consumer packaging, however there are other typical types of blow molded parts, including, but not limited to:

- Industrial bulk containers
- Lawn, garden and household items
- Medical supplies and parts, toys
- Building industry products
- Automotive-under the hood parts
- Appliance components

There are three types of blow moulding process:

(A) extrusion blow moulding

(B) Spin trimming

(C) Injection blow moulding

Extrusion blow moulding

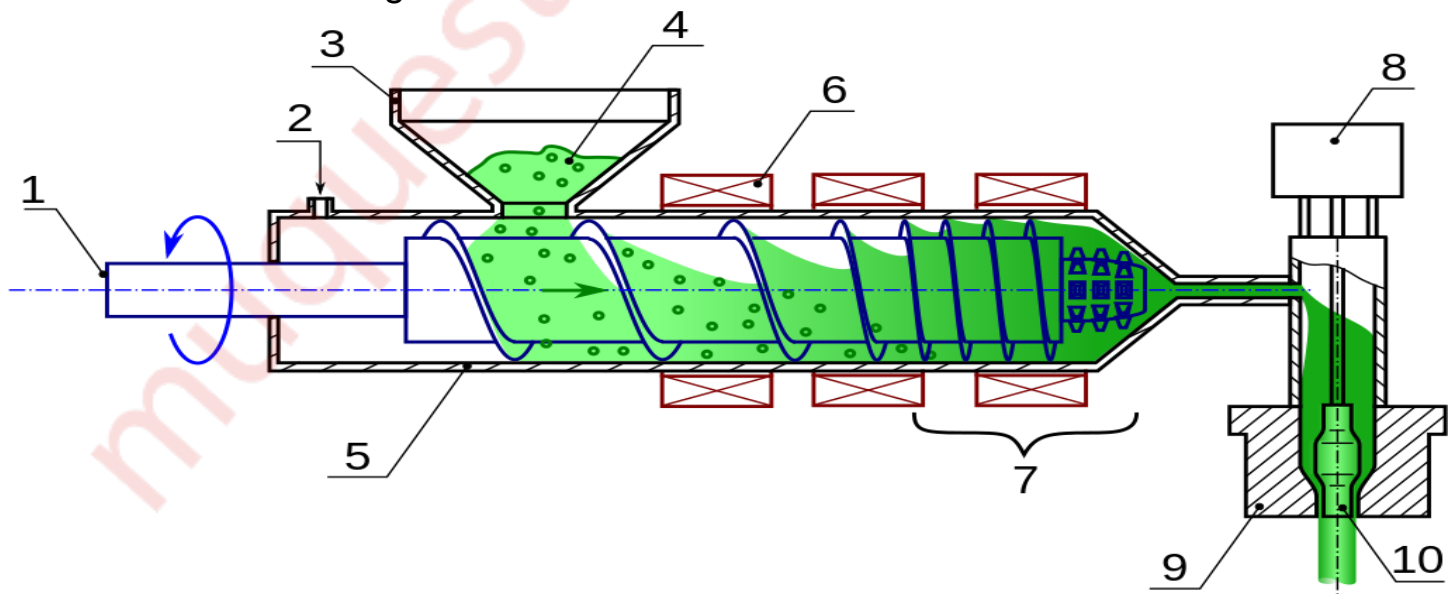

In extrusion blow molding (EBM), plastic is melted and extruded into a hollow tube (a parison). This parison is then captured by closing it into a cooled metal mold. Air is then blown into the parison, inflating it into the shape of the hollow bottle, container, or part. After the plastic has cooled sufficiently, the mold is opened and the part is ejected. Continuous and Intermittent are two variations of Extrusion Blow Molding. In continuous extrusion blow molding the parison is extruded continuously and the individual parts are cut off by a suitable knife. In Intermittent blow molding there are two processes: straight intermittent is similar to injection molding whereby the screw turns, then stops and pushes the melt out. With the accumulator method, an accumulator gathers melted plastic and when the previous mold has cooled and enough plastic has accumulated, a rod pushes the melted plastic and forms the parison. In this case the screw may turn continuously or intermittently. With continuous extrusion the weight of the parison drags the parison and makes calibrating the wall thickness difficult. The accumulator head or reciprocating screw methods use hydraulic systems to push the parison out quickly reducing the effect of the weight and allowing precise control over the wall thickness by adjusting the die gap with a parison programming device.

Spin trimming

Containers such as jars often have an excess of material due to the molding process. This is trimmed off by spinning a knife around the container which cuts the material away. This excess plastic is then recycled to create new moldings. Spin Trimmers are used on a number of materials, such as PVC, HDPE and PE+LDPE. Different types of the materials have their own physical characteristics affecting trimming.

Injection blow molding

The process of injection blow molding (IBM) is used for the production of hollow glass and plastic objects in large quantities. In the IBM process, the polymer is injection molded onto a core pin; then the core pin is rotated to a blow molding station to be inflated and cooled. This is the least-used of the three blow molding processes, and is typically used to make small medical and single serve bottles. The process is divided into three steps: injection, blowing and ejection.

(b) Describe reaction moulding of polymers with a neat labeled sketch. (10)

SOLUTION:

Reaction injection molding (RIM) is similar to injection molding except thermosetting polymers are used, which requires a curing reaction to occur within the mold.

Common items made via RIM include automotive bumpers, air spoilers, and fenders.

Process:

The process begins with two liquids: isocyanate and polyol (for polyurethanes), which are stored in large tanks. High-pressure pumps circulate the liquids between the tanks and a multi-stream mix-head in a speedy, continuous loop. A piston then retracts inside the mix-head, breaking the loop and allowing the two liquids to combine.

The liquids are mixed at high velocity (1200 psi) using an impinging mixer before being transferred into the mold for the curing process. As liquid polymers require less pressure and lower temperatures to complete the part than traditional ingredients such as metals, RIM provides a further money-saving benefit via the use of lightweight machined aluminum molds.

The mixed polymer cures inside the mold using a combination of low pressure (approximately 100 psi) and heating of the mold to around 180 degrees Fahrenheit (82 degrees Celsius). Cure times within the mold vary from one to several minutes depending on the size, complexity and thickness of the part.

Reaction injection molding can produce strong, flexible, lightweight parts which can easily be painted. It also has the advantage of quick cycle times compared to typical vacuum cast materials. The bi-component mixture injected into the mold has a much lower viscosity than molten thermoplastic polymers, therefore large, light-weight, and thin-walled items can be successfully RIM processed. This thinner mixture also requires less clamping forces, which leads to smaller equipment and ultimately lower capital expenditures. Another advantage of RIM processed foam is that a high-density skin is formed with a low-density core.

The disadvantages are slow cycle times, compared to injection molding, and expensive raw materials.

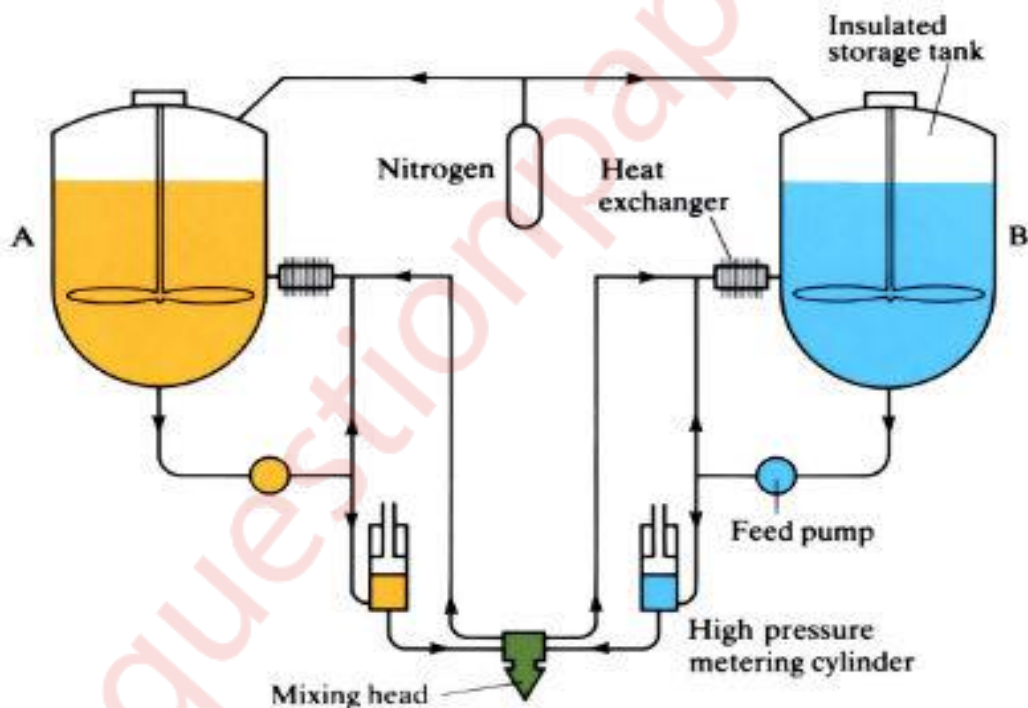

Q5. Attempt the following two questions:

(a) How does a gear cutting process differ from a Gear generating process? (10)

SOLUTION:

Gear cutting is any machining process for creating a gear. The most common gear-cutting processes include hobbing, broaching, milling, and grinding. Such cutting operations may occur either after or instead of forming processes such as forging, extruding, investment casting, or sand casting.

Gears are commonly made from metal, plastic, and wood. Although gear cutting is a substantial industry, many metal and plastic gears are made without cutting, by processes such as die casting or injection molding. Some metal gears made with metallurgy require subsequent machining, whereas others are complete after sintering. Likewise, metal or plastic gears made with additive manufacturing may or may not require finishing by cutting, depending on application.

Gear forming

In gear form cutting, the cutting edge of the cutting tool has a shape identical with the shape of the space between the gear teeth. Two machining operations, milling and broaching can be employed to form cut gear teeth.

Form milling

In form milling, the cutter called a form cutter travels axially along the length of the gear tooth at the appropriate depth to produce the gear tooth. After each tooth is cut, the cutter is withdrawn, the gear blank is rotated, and the cutter proceeds to cut another tooth. The process continues until all teeth are cut

Broaching

Broaching can also be used to produce gear teeth and is particularly applicable to internal teeth. The process is rapid and produces fine surface finish with high dimensional accuracy. However, because broaches are expensive and a separate broach is required for each size of gear, this method is suitable mainly for high-quality production.

Gear generation

In gear generating, the tooth flanks are obtained as an outline of the subsequent positions of the cutter, which resembles in shape the mating gear in the gear pair. There are two machining processes employed shaping and milling. There are several modifications of these processes for different cutting tool used.

Gear hobbing

Gear hobbing is a machining process in which gear teeth are progressively generated by a series of cuts with a helical cutting tool. All motions in hobbing are rotary, and the hob and gear blank rotate continuously as in two gears meshing until all teeth are cut.

(b) How can a lathe machine be specified for the purpose of purchase?

(10)

SOLUTION:

Recorded history shows that the lathe is an ancient tool, perhaps first appearing 3,300 years ago in ancient Egypt as a manual, two-person operation. During the Industrial Revolution, mechanized power allowed for faster and easier work. In the later 19th and early 20th centuries, electricity made the machines even more powerful, and the advent of servomotors in the 1950s added the element of control.

One of the key characteristics of a lathe, unlike a vertical or horizontal milling machine, is that the work piece turns, as opposed to the tool. Thus, lathe work is often called turning. Turning, then, is a machining process used to make round, cylindrical parts. Lathes are commonly used to reduce the diameter of a work piece to a specific dimension, producing a smooth surface finish. Basically, the cutting tool approaches the rotating work piece until it begins peeling away the surface as it moves linearly across the side (if the part is a shaft) or across the face (if the part is drum-shaped).

Very few lathes today are not controlled by a CNC, although you can still buy a manually controlled lathe. When equipped with means for changing tools out automatically, such as with a tool turret, the CNC lathe is more properly called a turning center. CNC turning centers are available in a wide range of sizes and capabilities, from simple two-axis lathes, which move in only X and Y, to more sophisticated, multi-axis turning centers capable of handling complex four-axis turning operations, milling, drilling, tapping and deep-hole boring—all in one operation.

Basic Lathe Configuration

The basic two-axis lathe consists of a headstock with spindle, chuck for holding the part, lathe bed, carriage and cross-slide, tool turret and tailstock. While most lathes have a moveable tailstock to support the work piece at the end, away from the chuck, not all machines come with this feature as a standard. A tailstock is particularly useful, however, when the work piece is relatively long and slender. Failing to use a tailstock in this case can cause “chatter,” which leaves telltale marks on the surface of the part. Unsupported, the part itself can become tapered, because it may bend excessively from tool pressure while being cut.

When considering adding a tailstock as an option to a lathe, pay attention not only to the current job being run, but also the size of future work. When in doubt, include the tailstock with the initial machine purchase. This recommendation will likely save the headache and expense of installing one later.

Machine Specifications

Regardless of how many axes of motion are required, in evaluating the purchase of any lathe, a shop must first consider the size, weight, geometric complexity, required accuracy and material of the parts being machined. The expected number of parts in each batch also should be taken into account.

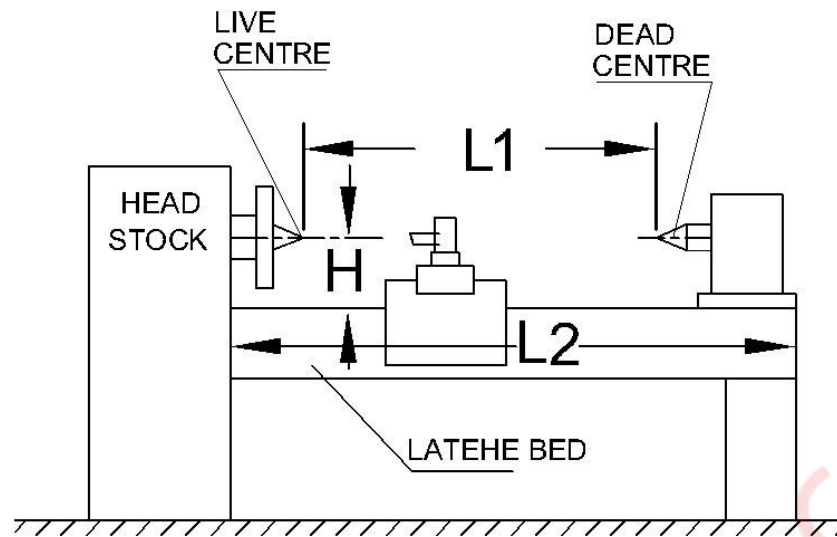

SPECIFICATION OF LATHE MACHINE

Common to all lathe purchases is the question of the size of chuck to hold the intended parts. For turning centers, chucks generally range in capacity from 5 to 66 inches in diameter, or even larger. When parts or barstock must extend through the back of the chuck, maximum spindle through-hole or barstock capacity is important. Machines designed with “big-bore” options are available if the standard through-hole size is not large enough.

The next critical spec is the swing diameter, or maximum turning diameter. This figure indicates the largest-diameter part that could fit in the chuck and still swing over the bed without hitting. Equally important is the maximum turning length required. This work piece dimension determines the necessary bed length of the machine. Note that maximum turning length is not the same as bed length. For example, if the part being machined is 40 inches long, the machine bed will need to be much longer to effectively turn the full length of that part.

Finally, the number of parts to be machined and the required accuracy are prime factors for specifying the capability and the quality of the machine. Machines for high production call for high-speed X and Y axes, with rapid-travel rates to match. Machines for close-tolerance work are designed to control thermal drift in ballscrews and key components. The machine structure may also be designed to minimize thermal growth.

Q6. Attempt the following two questions:

(a) What is meant by a 'Closed loop control system' and an 'open loop control system'?
(10)

SOLUTION:

Control systems are used to arrange and manage components in a way that the required condition or output is obtained.

There are two attributes of control system:

1. Stability
2. Desired output

A control system can be functioned electrically, mechanically, pressure by fluid (gas or liquid), or it can be combination of these ways.

Open loop control system:

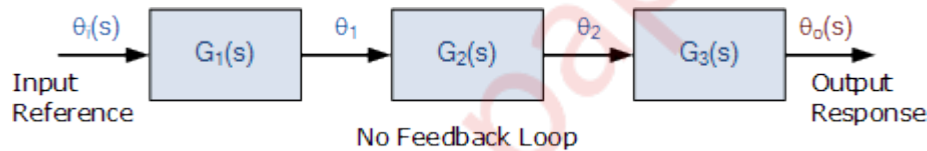

An open-loop control system takes input under the consideration and doesn't react on the feedback to obtain the output. This is why it is also called a non-feedback control system.

Then we can define the main characteristics of an "Open-loop system" as being:

- There is no comparison between actual and desired values.
- An open-loop system has no self-regulation or control action over the output value.
- Each input setting determines a fixed operating position for the controller.
- Changes or disturbances in external conditions do not result in a direct output change (unless the controller setting is altered manually).

E.g.:

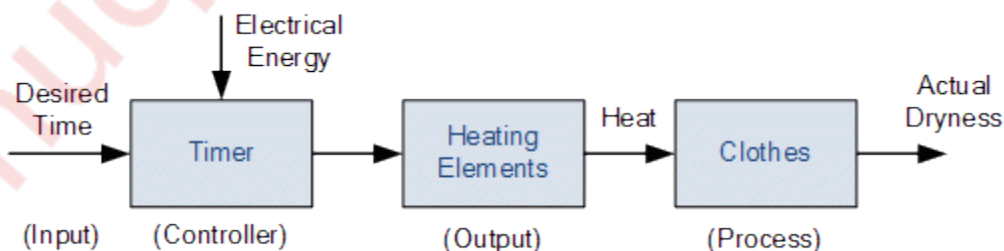

Closed loop control system:

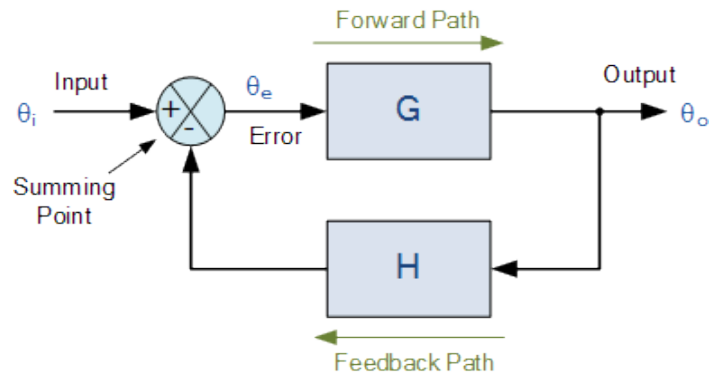

A closed loop system is also referred as a feedback control system. These systems record the output instead of input and modify it according to the need. It generates preferred condition of the output as compared to the original one. It doesn't encounter any external or internal disturbances.

Then we can define the main characteristics of Closed-loop Control as being:

- To reduce errors by automatically adjusting the systems input.
- To improve stability of an unstable system.
- To increase or reduce the systems sensitivity.
- To enhance robustness against external disturbances to the process.
- To produce a reliable and repeatable performance.

E.g.:

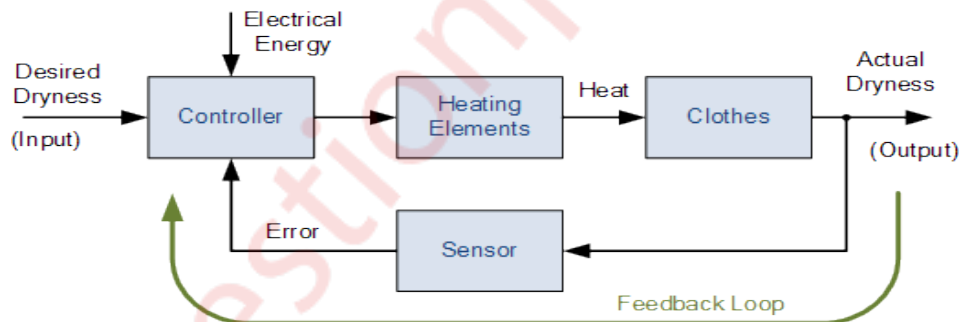

(b) What is transfer line machine? Draw a neat labeled sketch.

(10)

SOLUTION:

The term transfer indicates the transfer of work piece from one station to another station during the manufacturing process. The unmachined work pieces are loaded at one end and the machined work piece leave the transfer line at the other end. The transfer machine or transfer line consists of several machining heads, or units fastened together by conveying units. Transfer machines permit the maximum number of operations to be performed on work pieces at a maximum production rate.

Transfer units are commonly used in automobile industry, air-craft industry, etc.

Operations done on transfer machine:

All types of machining operations such as drilling, boring, reaming, tapping and milling are economically combined on transfer machines. Lathe type operations such as turning and facing are performed by rotating the work pieces on selected work station.

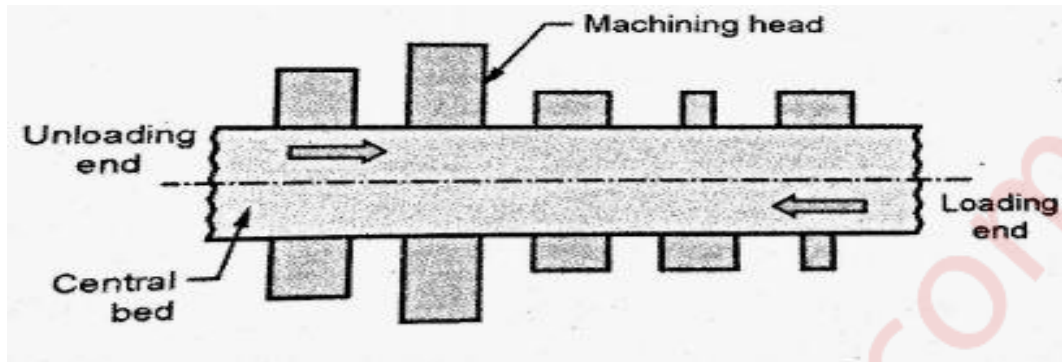

Transfer machines can be of the following types:

- In-line transfer machine.

It consists of a central bed and the machining heads are arranged on sides at a convenient pitch. The components are transferred along guide rails on the central bed. Central blocks, gear box casting and axle box castings are transfer machined by this method.

- Rotary Indexing table transfer machine.

A rotary indexing table is used for transferring components from fixed stations of machining heads, which are spaced at equal intervals around the periphery of the table. These machines are small in size. It saves floor space and presents more compact arrangement. It can also be installed for complete automatic assembly of a product.

- Drum Type transfer machine.

Like rotary table type, this machine also transfers the components in a circular path to workstations positioned around at equal distances. This machine instead of having a table has got a drum which rotates about a horizontal axis. The work fixtures are fixed around the periphery of the drum.