

Q.P.CODE:16287

**ENGINEERING**

**DRAWING**

**DEC 22**

MUQuestionPapers.com



Sol:

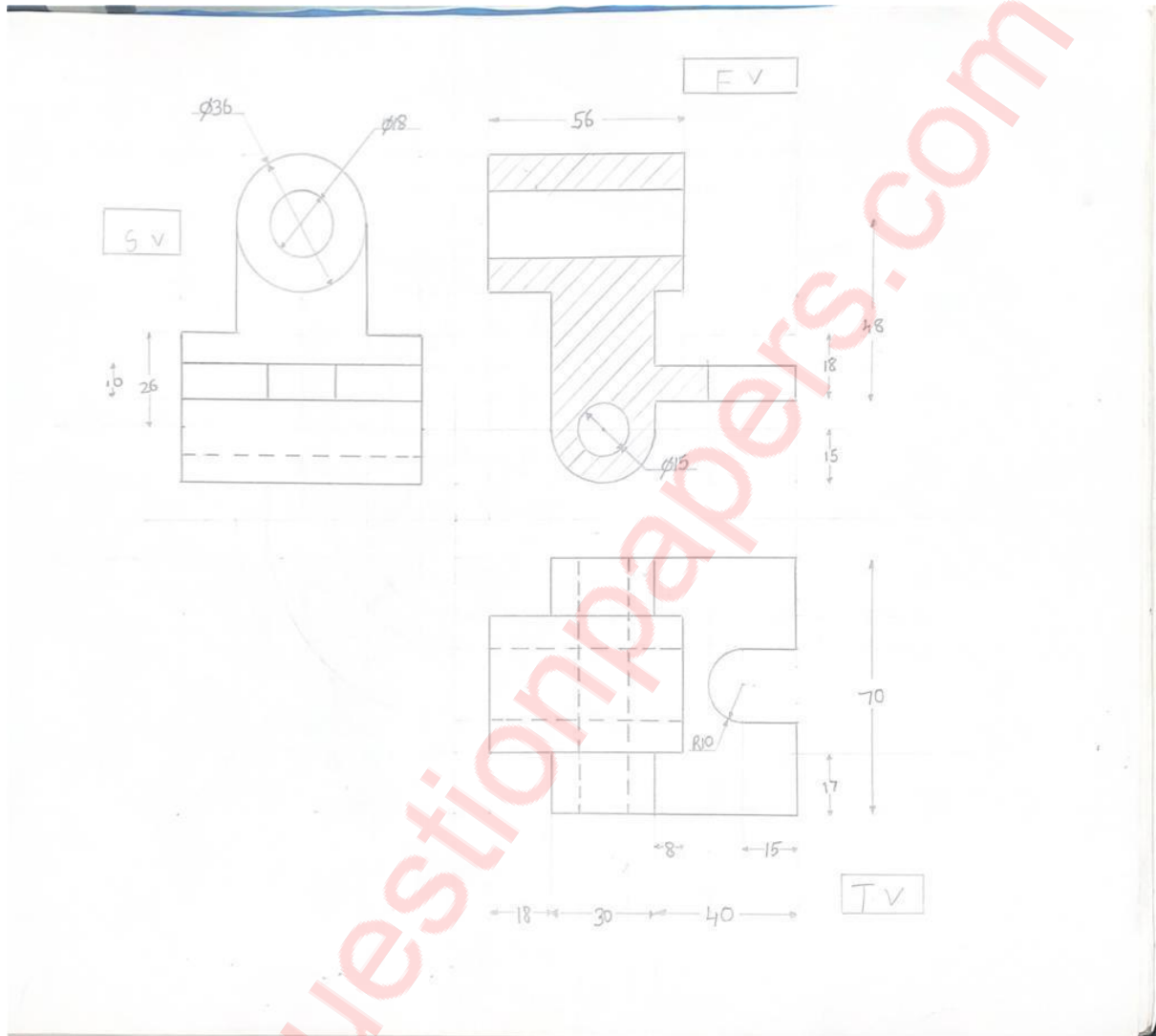

Q.2 [a] A cylinder of diameter 50 and axis 65 mm long is lying on H.P on its curved surface with axis inclined a 45 degree to V.P and parallel to H.P. Draw the projections of cylinder. [6]

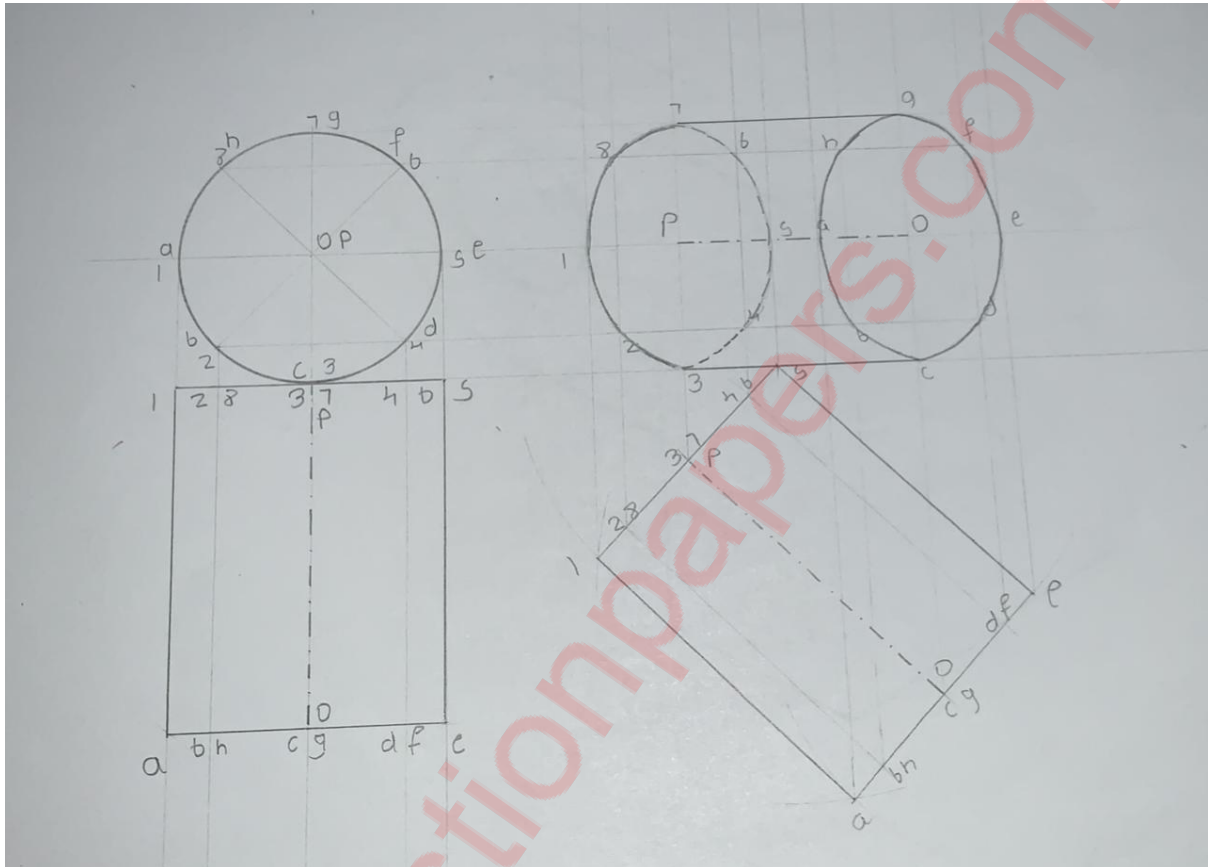

[b] Draw the isometric view of the object whose FV and TV are as given below.

[9]

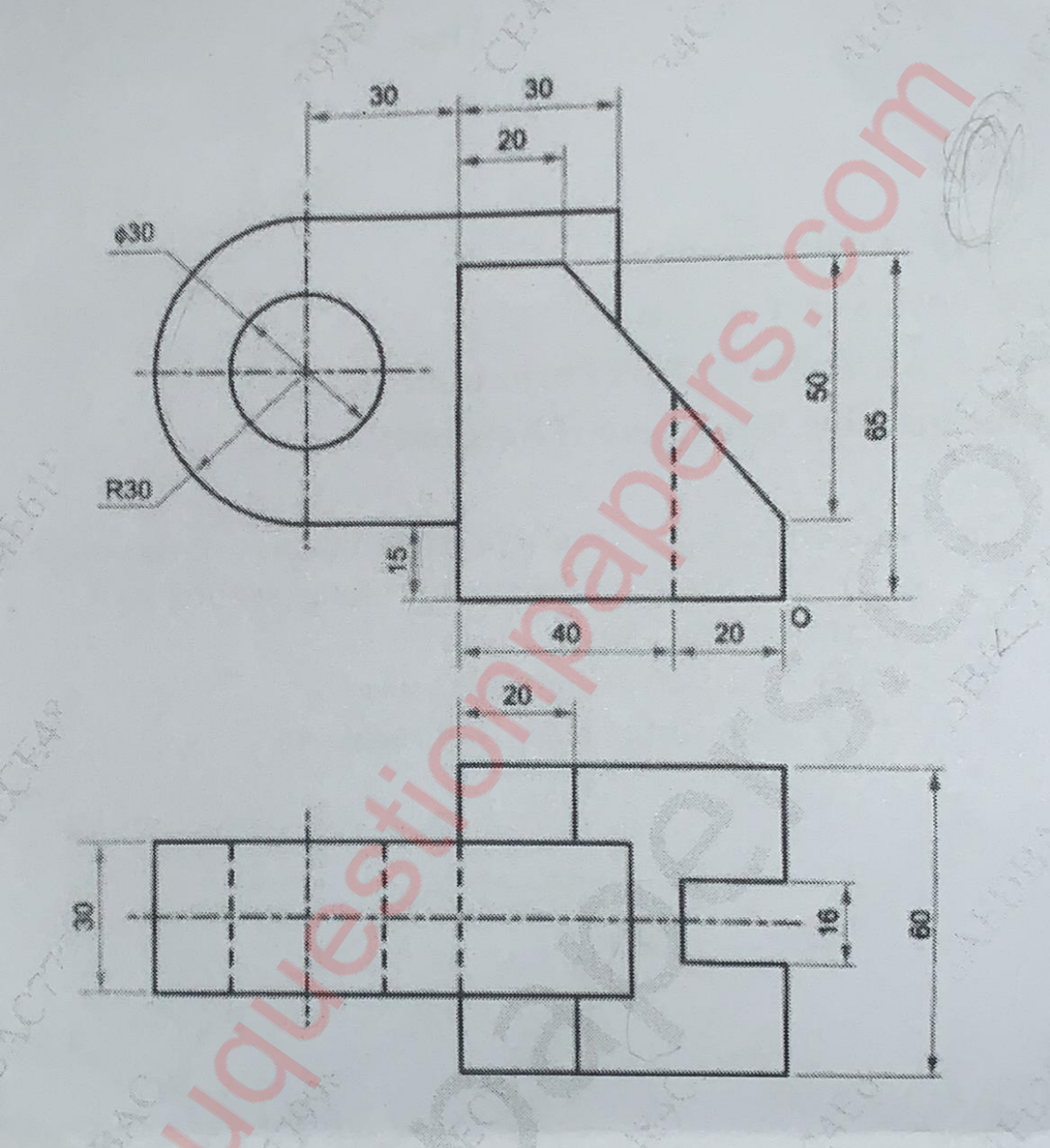

Sol:

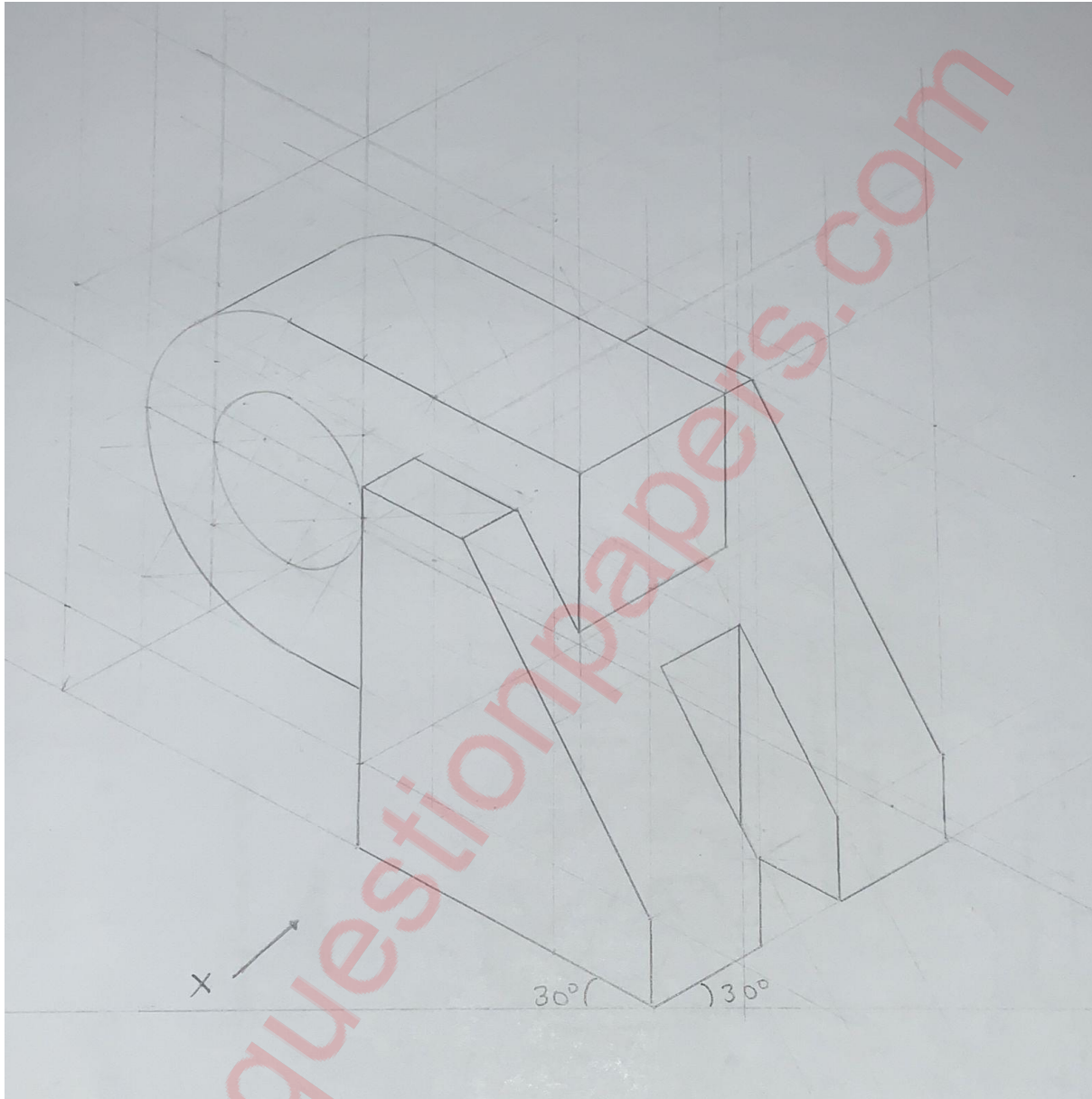

Q.3 [A] The pictorial view of a machine part is shown in following figure

Draw

1. Front view from the direction "X". [4]
2. Top view [4]
3. Insert at least 6 Dimensions. [1]

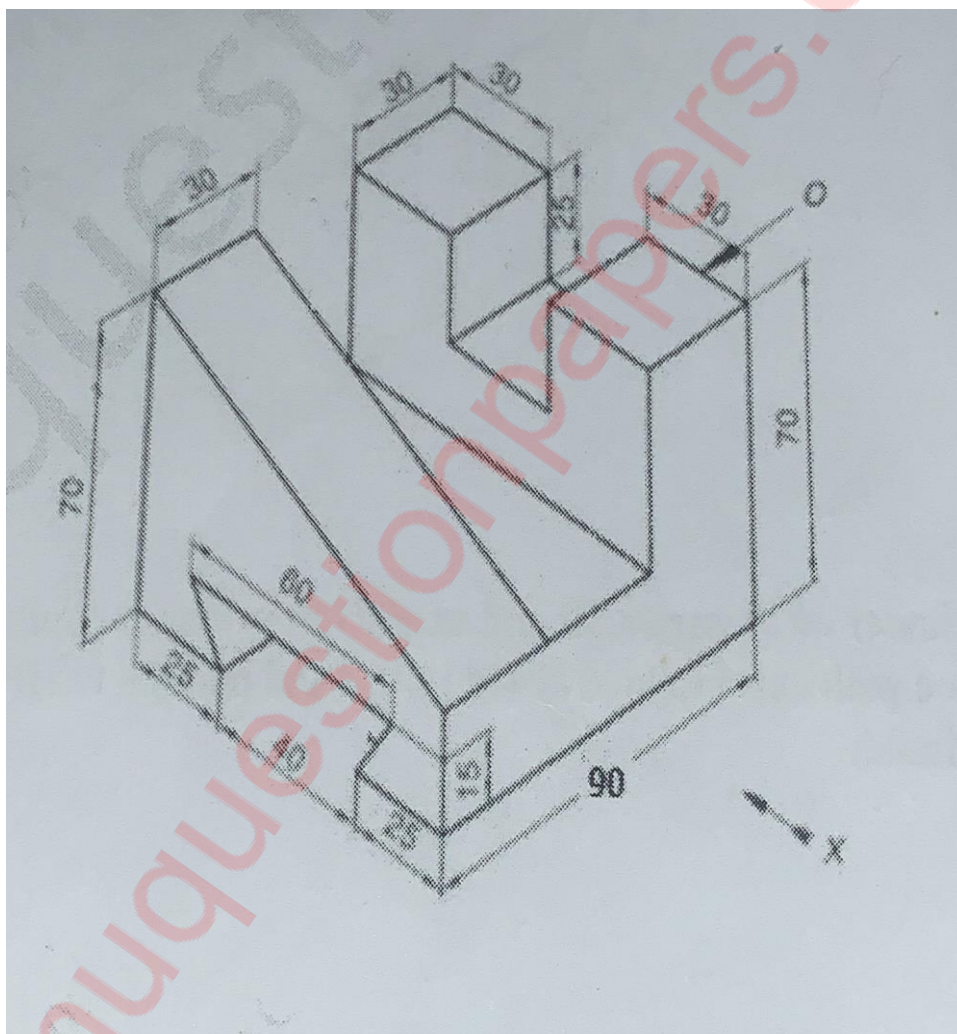

Sol:

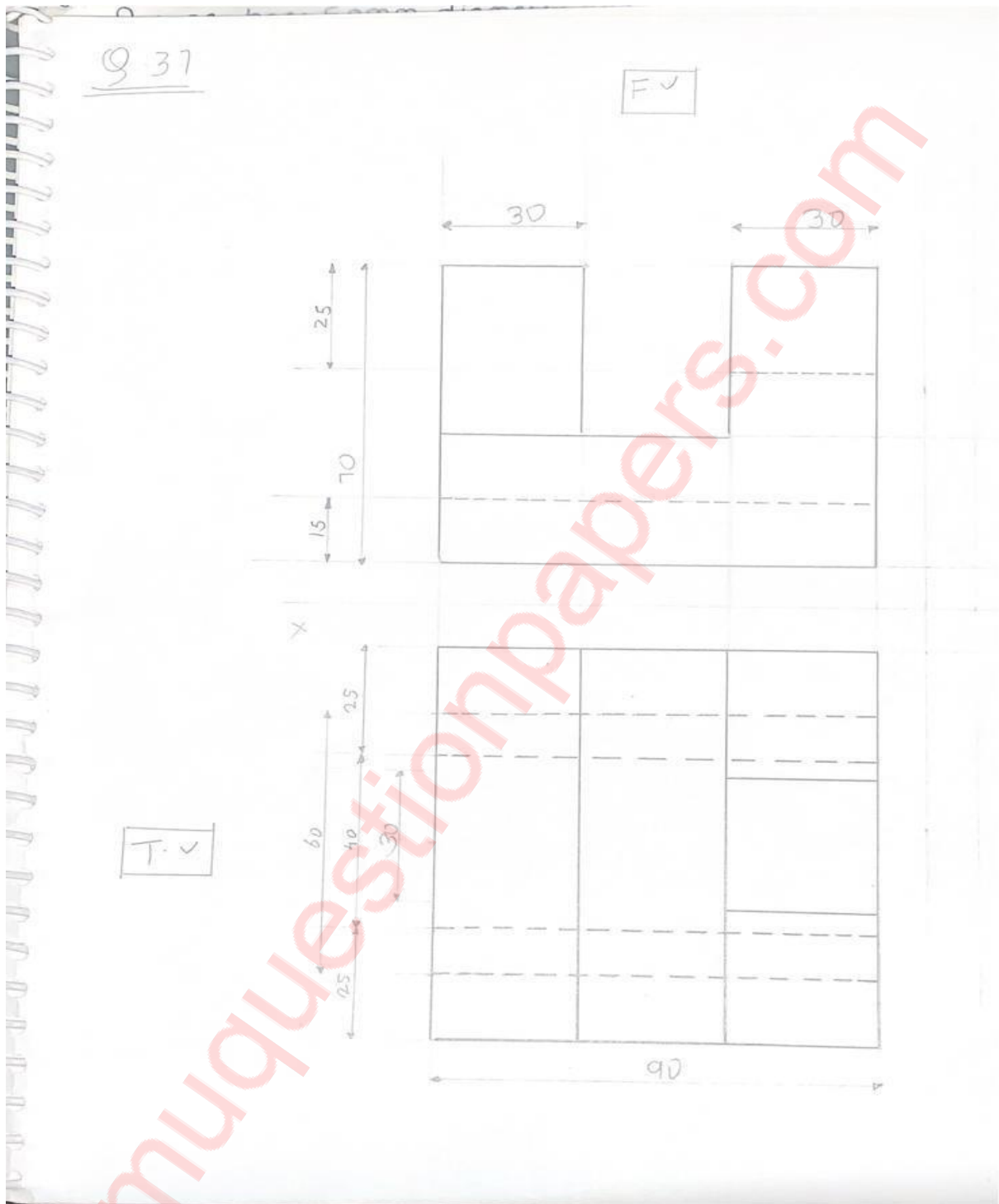



[b] One end of a string, AB, of length 140mm is wound round a disc of diameter 50mm by keeping one end, A, fixed on the disc and keeping the string always tight. Draw the locus traced by the other end of the string B. Name the curve.

[6]

Sol:

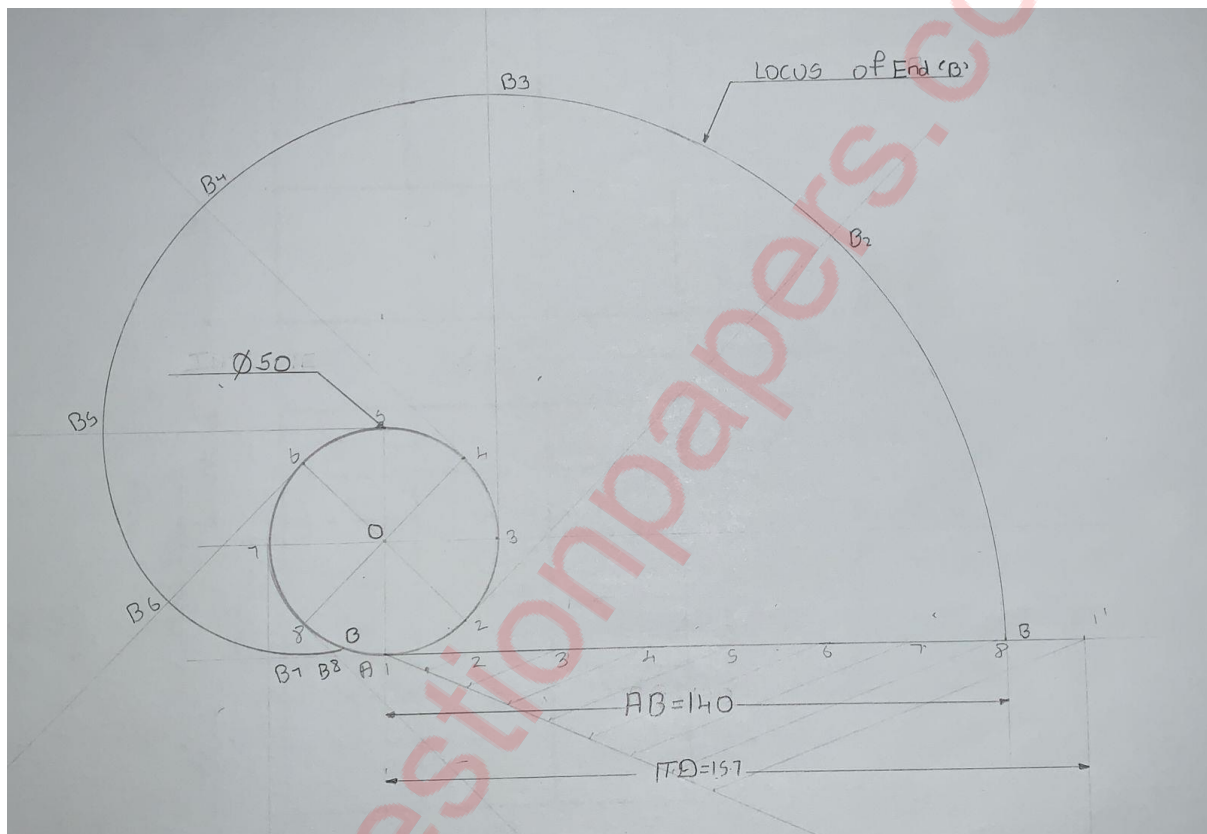

Q.4 A pentagonal pyramid, side of base 35 mm and axis 65mm long is resting on one of its corners on HP such that one of the triangular surfaces is parallel to HP and perpendicular to VP. Draw the projections of solid when the base edge containing that triangular surface is parallel to both HP and VP. The apex of the pyramid is being nearer to observer.

[15]

Sol:

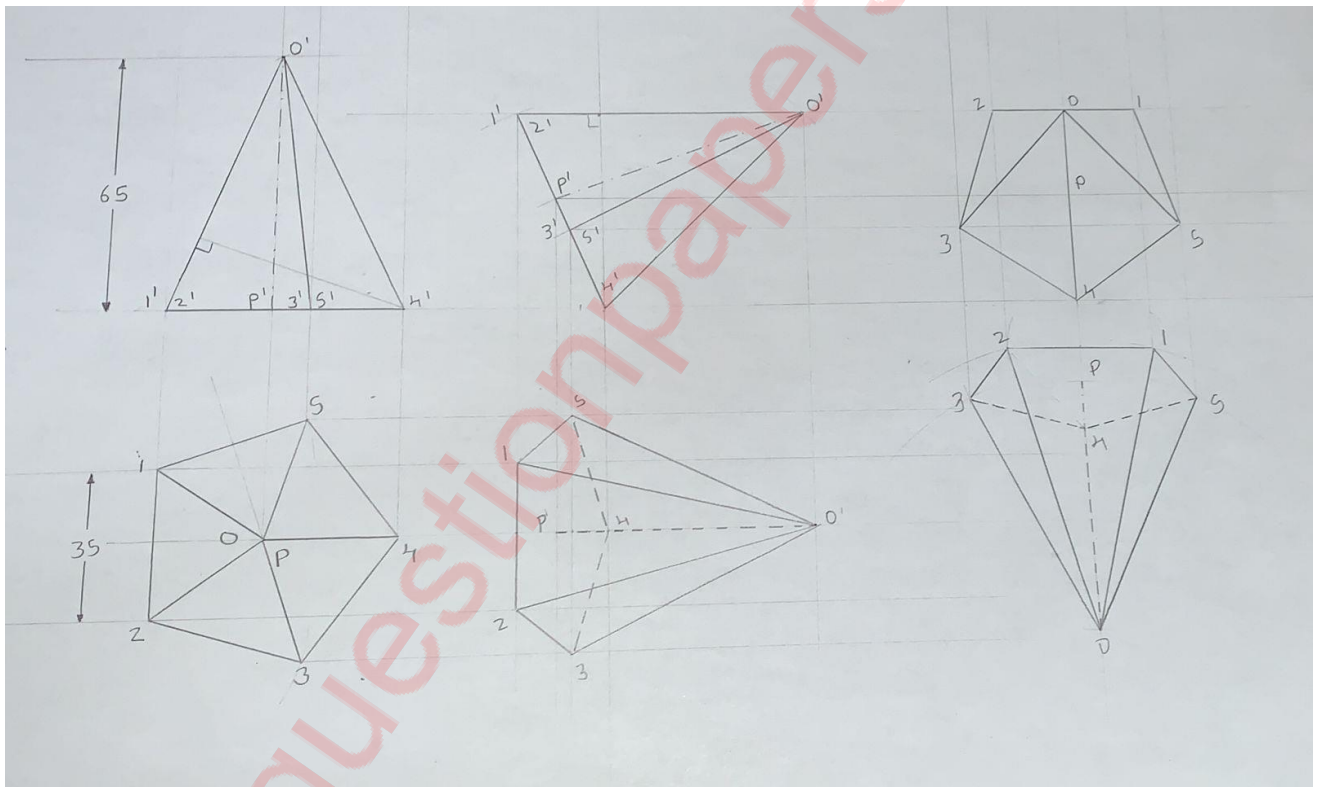

Q.5 One end P of a line PQ is in the HP and 25 mm in front of VP while other end Q is on VP and 50 mm below HP. Draw projections of line PQ and find its inclinations with HP and VP if the true length of PQ is 70mm.

[15]

Sol:

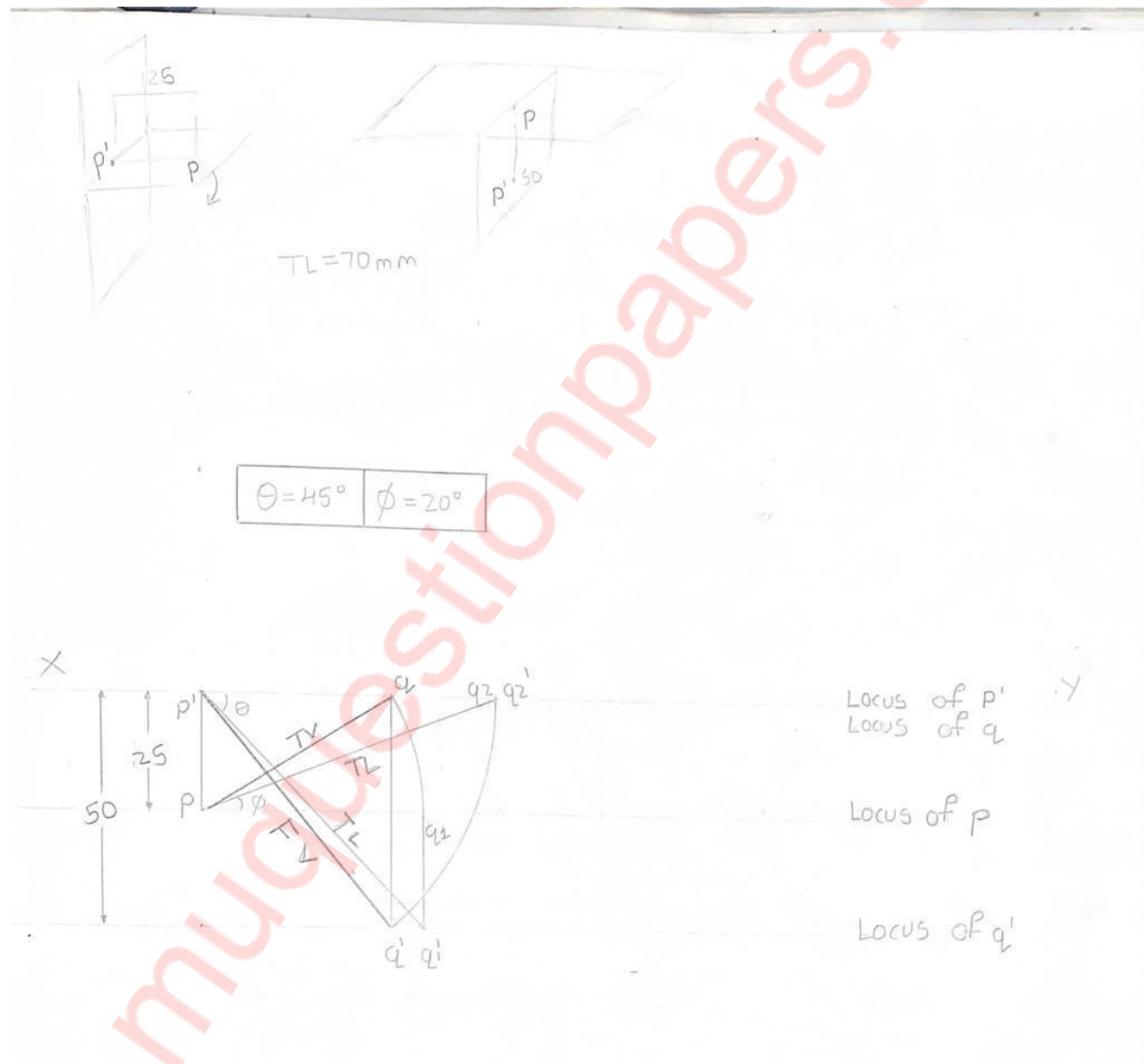

Q.6 [A] The FV and TV of an object is shown below. Draw the Isometric view of the object.

[8]

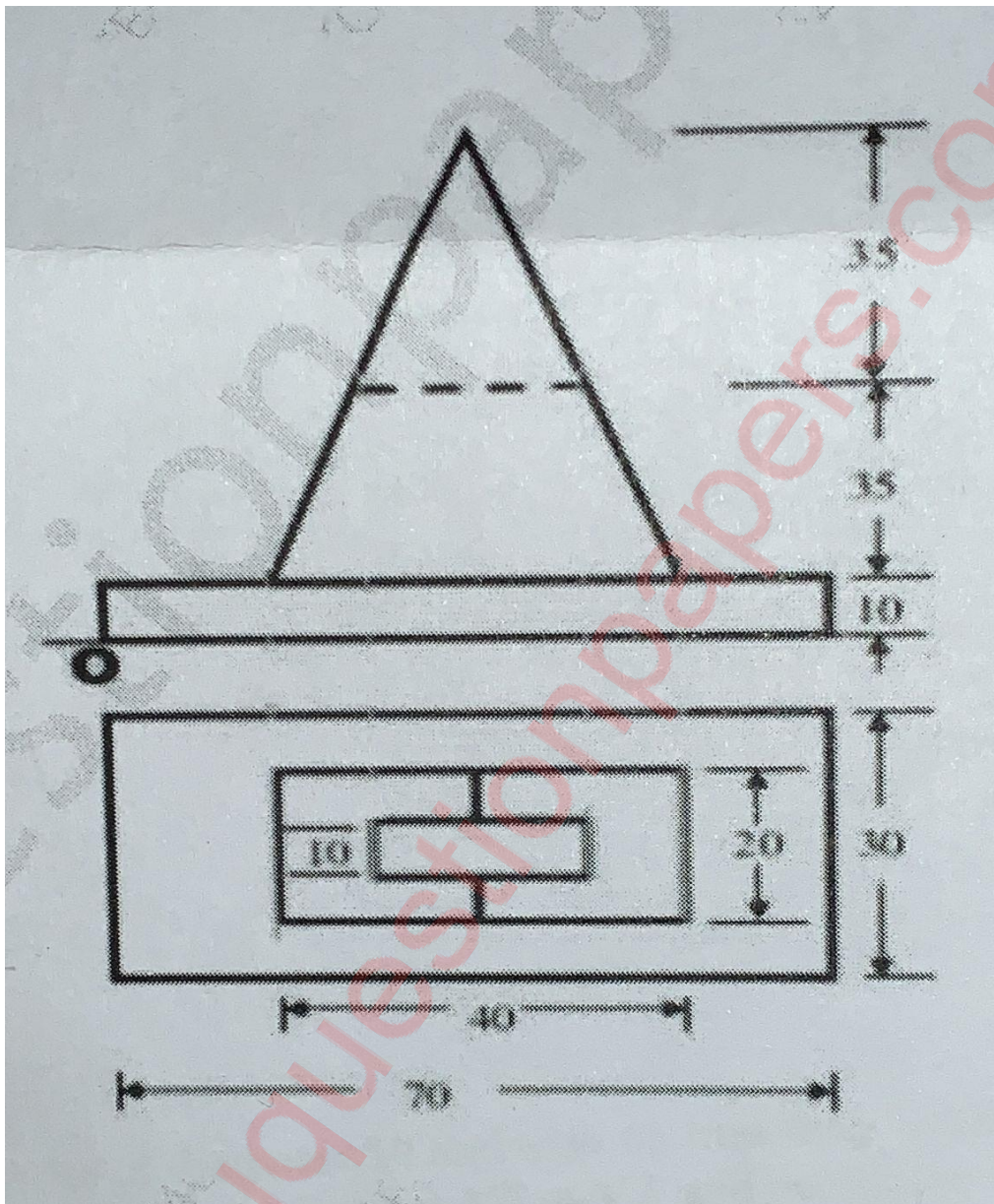

Sol:

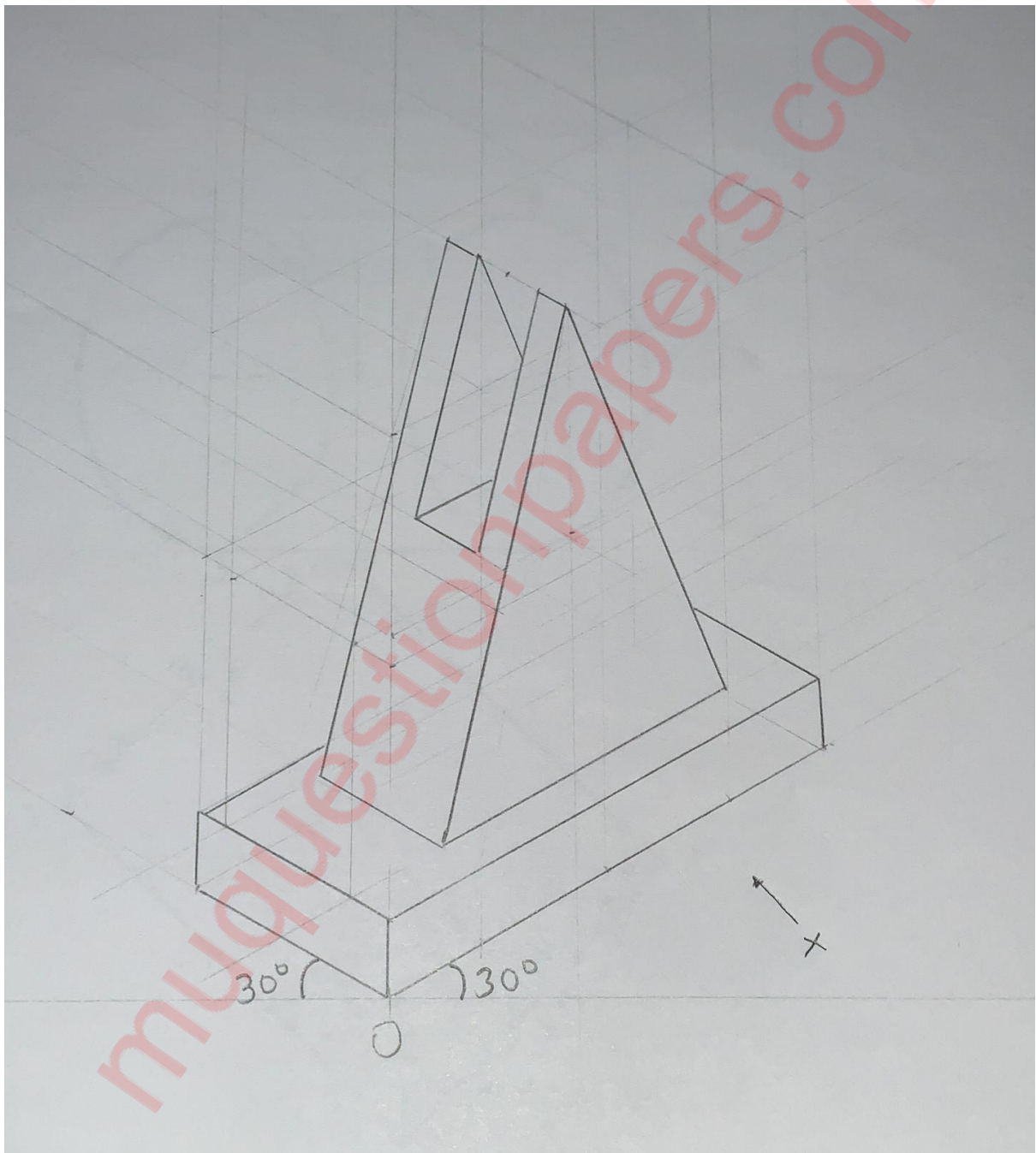

MUQuestionPapers.com

[b] A hexagonal prism of side of base 35 mm and axis 65mm long is resting on one of its base edges on HP such that the base of the prism is inclined 45 degrees to HP and axis parallel to VP . Draw the projections of prism.

[7]

Sol:

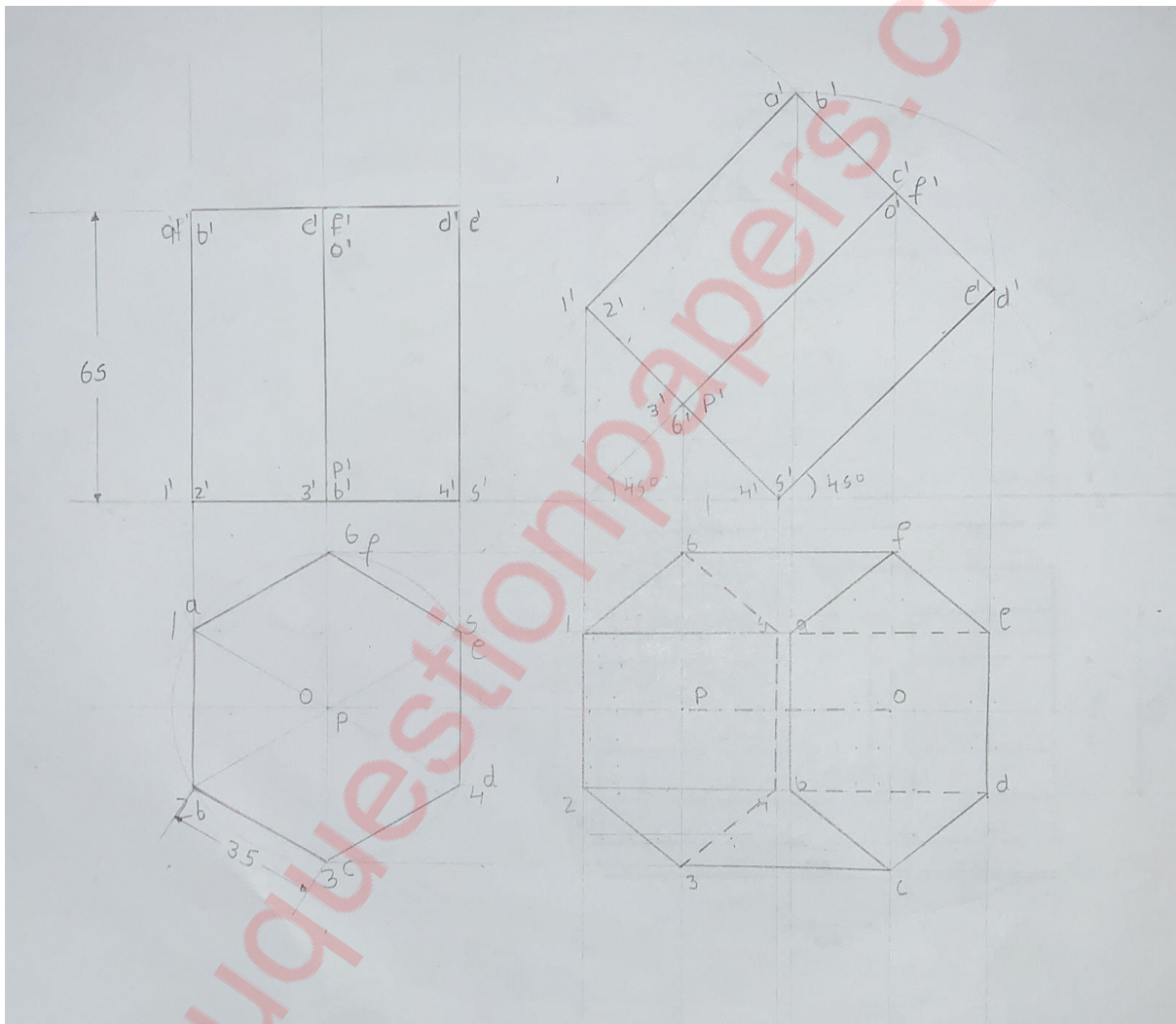

MUQuestionPapers.com