

Q.P.Code:72656

ENGINEERING DRAWING

DEC 19

Q.1 Following figure shows the pictorial view of an object, draw

i) Sectional front view along section A-A [05]

ii) Top view. [04]

iii) Left Hand Side view [04]

iv) Insert 10 major dimensions. [02]

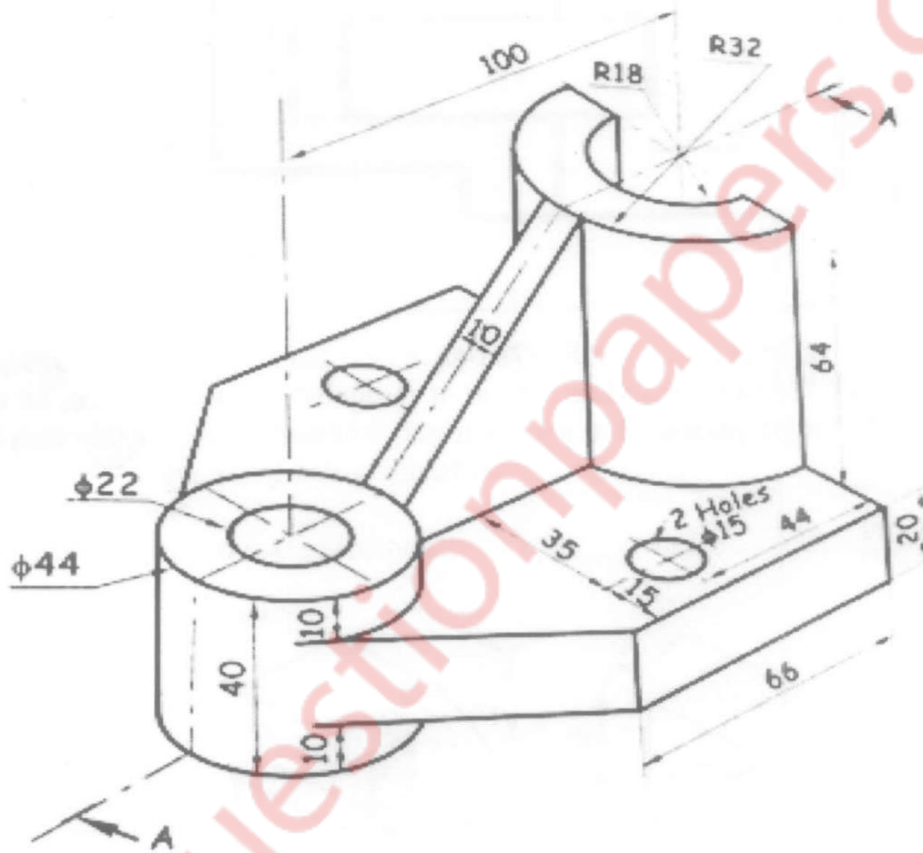

Sol:

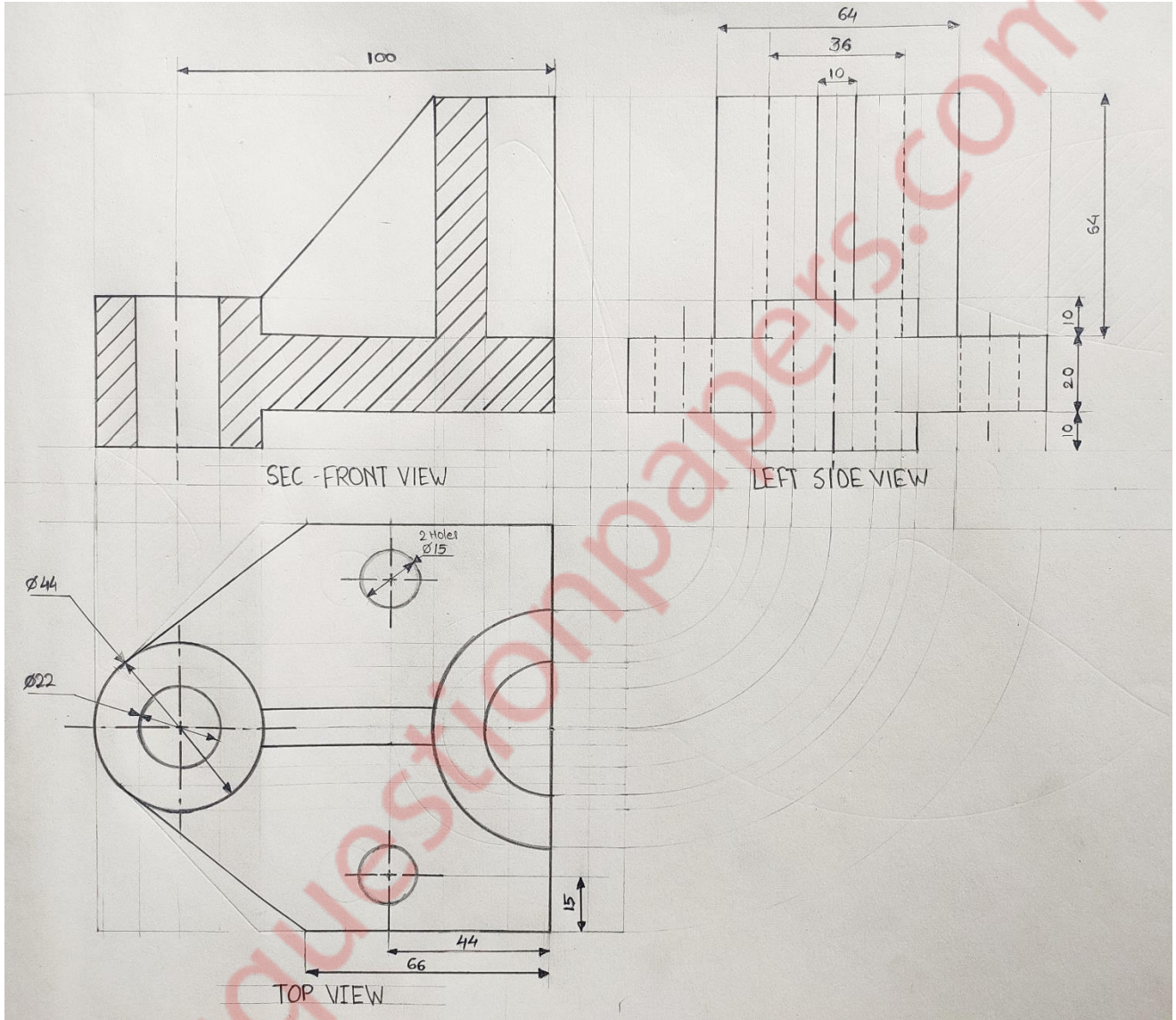

Q.2 A right circular cone of base 60mm diameter and axis 75mm long is lying on VP on one of its end generator. Draw projections of the cone when FV of the axis inclined 45° with HP and base nearer to observer. [15]

Sol:

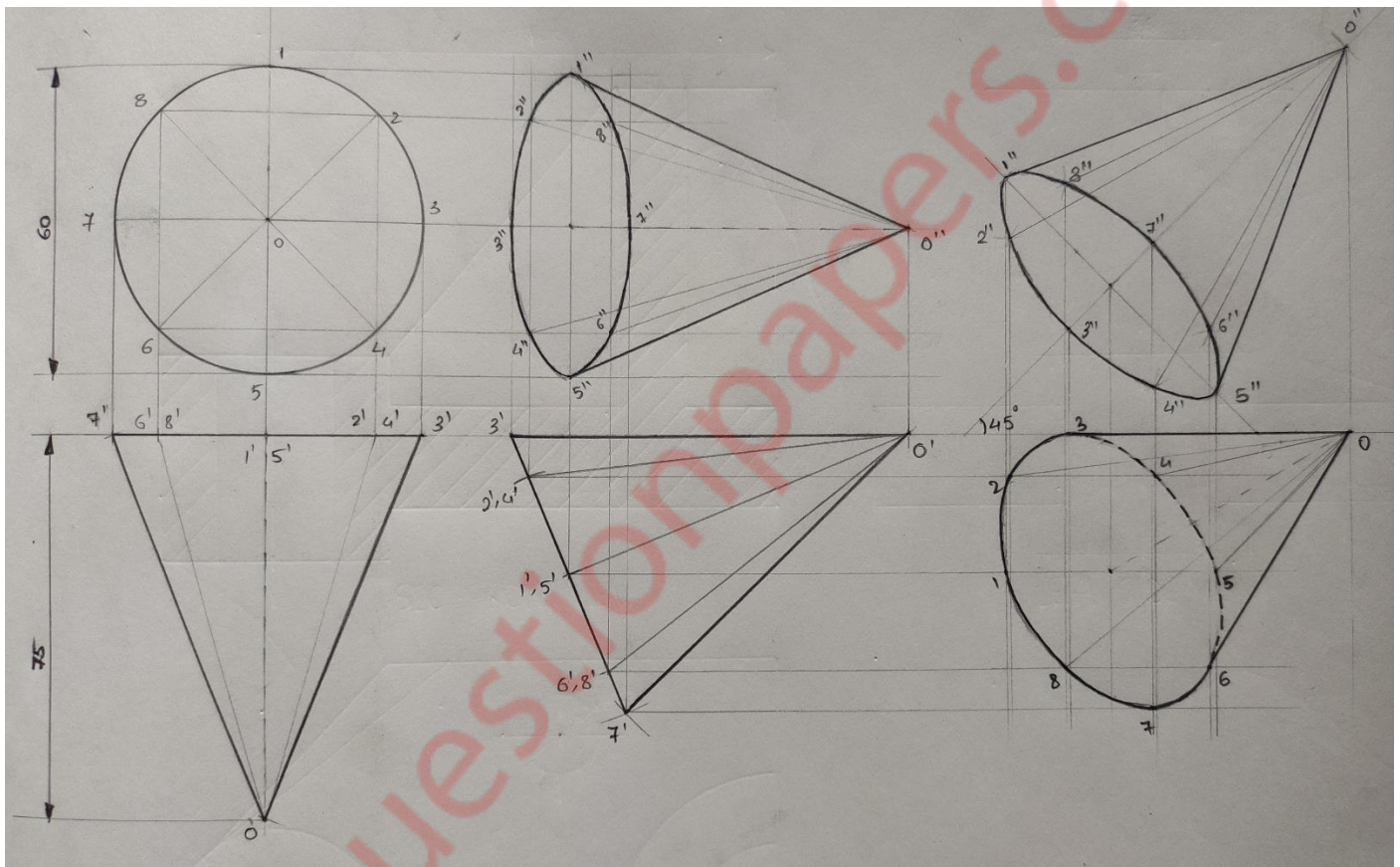

Q.3. (a) Front view and top view of an object is shown in figure, draw an Isometric View.

[09]

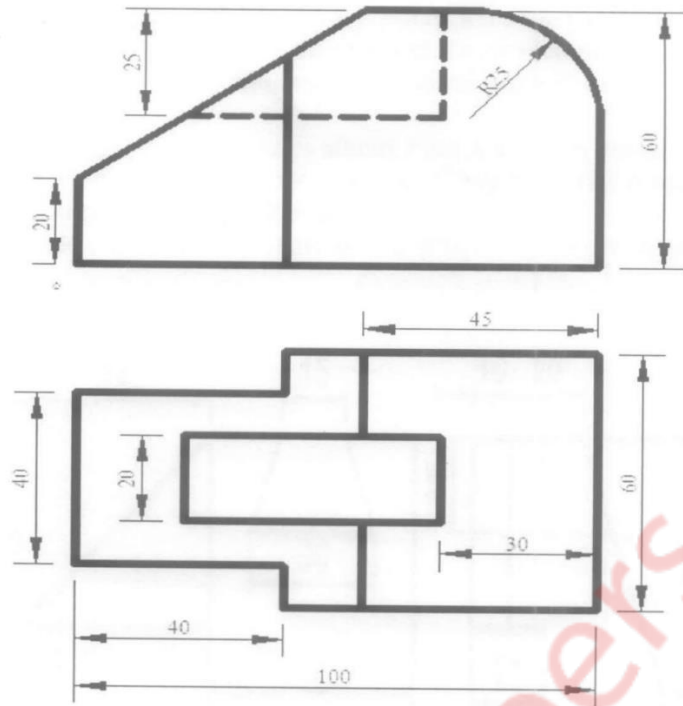

Sol:

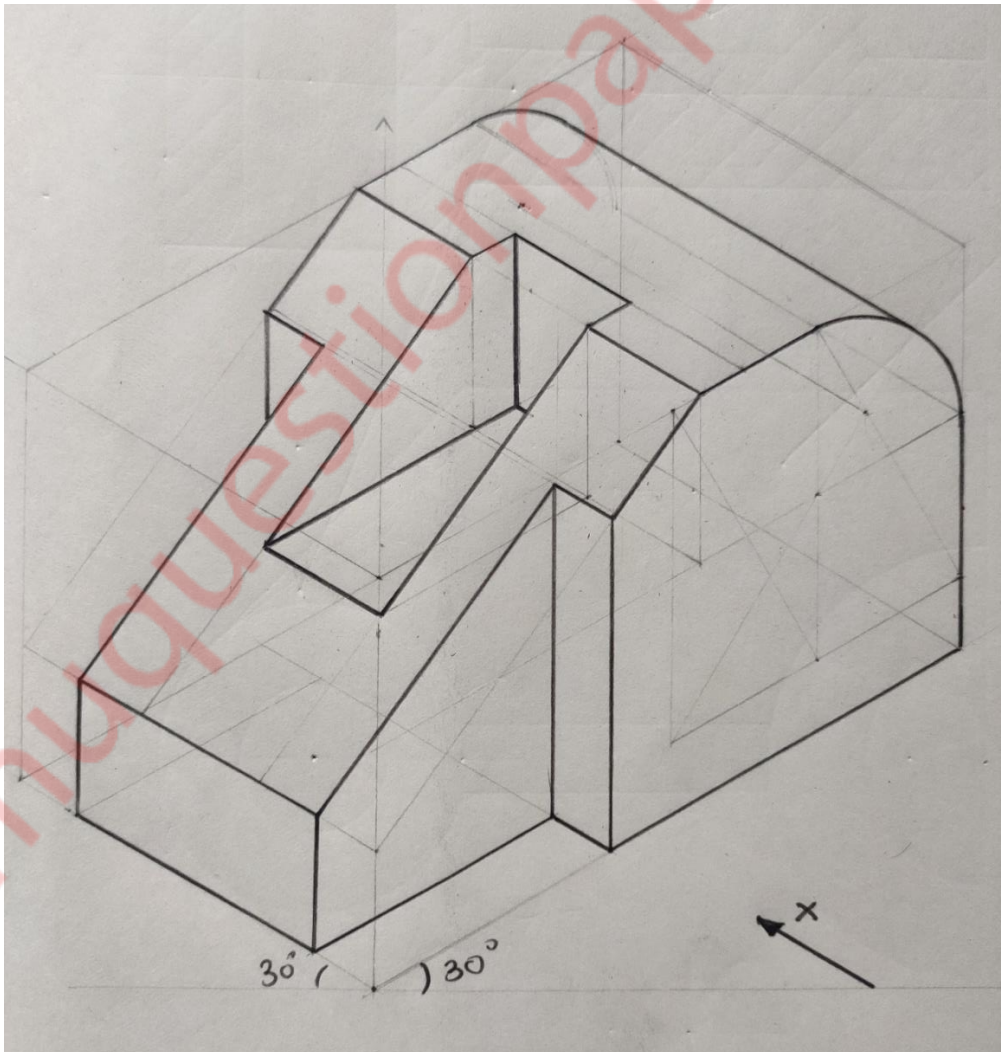

Q.3.(b) A square prism edge of base 35mm and axis 70mm has one of its base edges in the HP with its axis inclined at 40 degrees to the HP and parallel to VP. Draw its Projections. [06]

Sol:

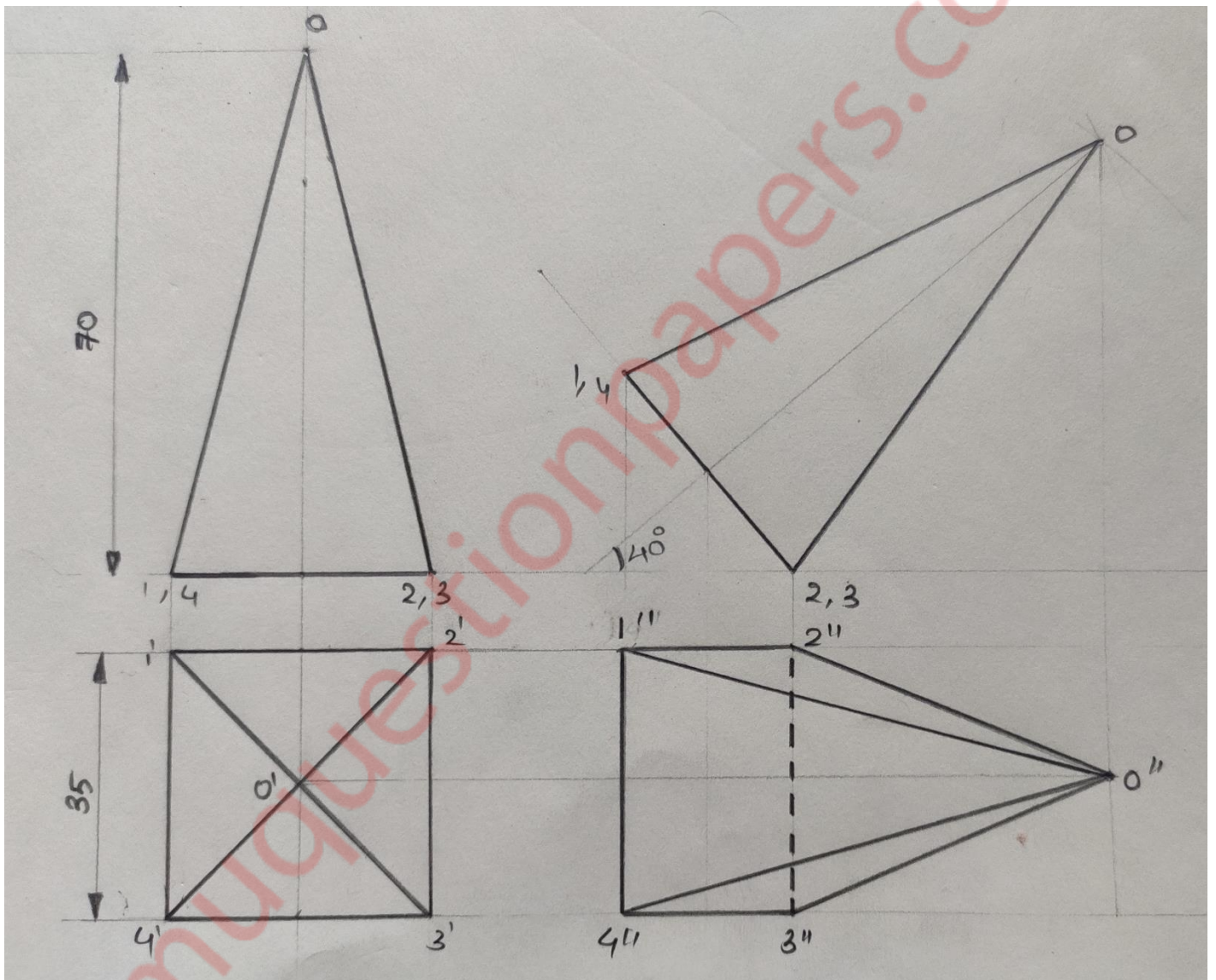

Q.4.(a) The pictorial view of a machine part is shown in the following figure. Draw

- i) Front view along arrow direction [04]
- ii) Top view [04]
- iii) Insert at least 6 Dimensions. [01]

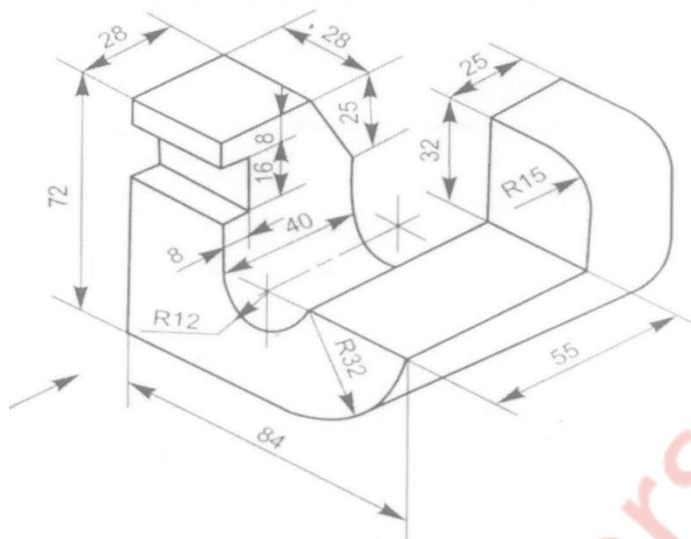

Sol:

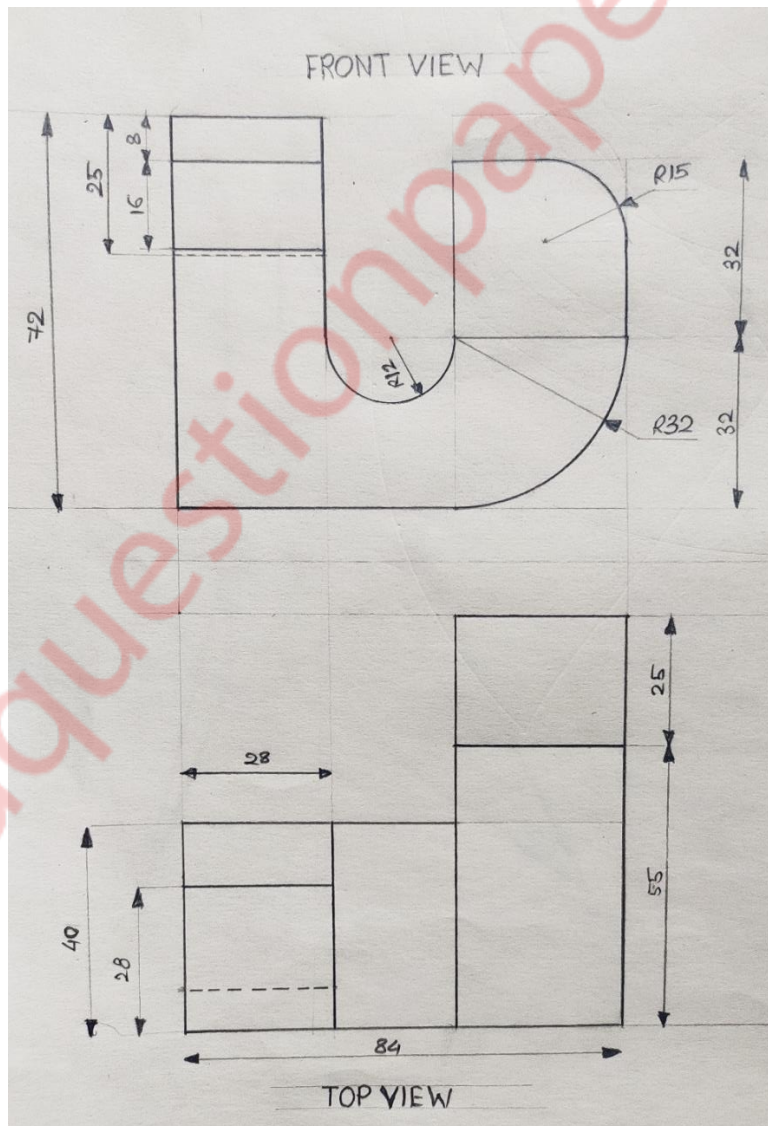

Q.4.(b) Draw a helix of pitch 80mm on a cylinder of 60mm diameter.

[06]

Sol:

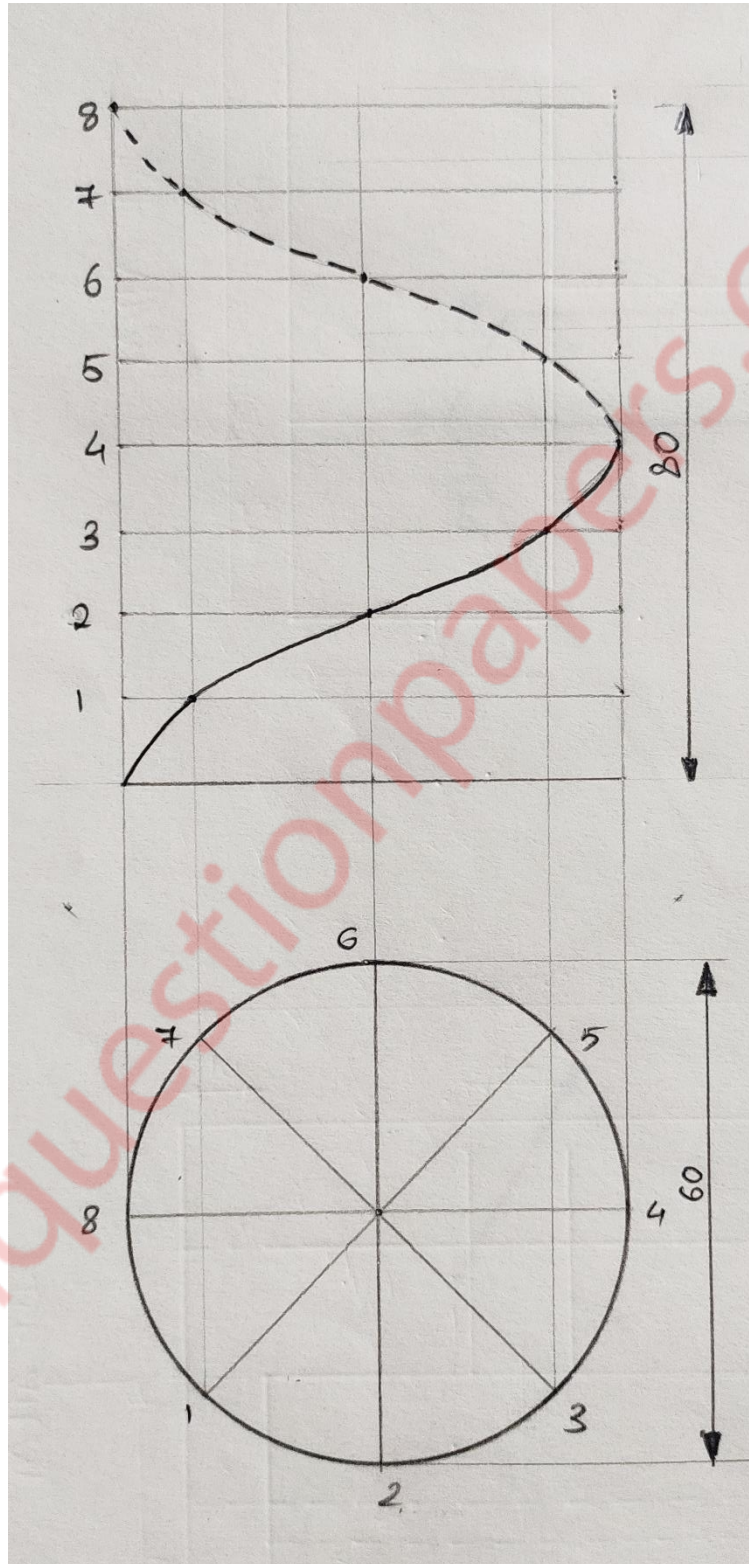

Q.5 A hexagonal pyramid of 30mm edge of base, 60mm axis length rests on its base on HP with an edge of base perpendicular to VP. It is cut by a section plane normal to VP and 60° inclined to HP bisects the axis of the pyramid. Draw sectional FV, sectional TV, True shape of section and Development of Lateral surface of the pyramid after removing apex. [15]

Sol:

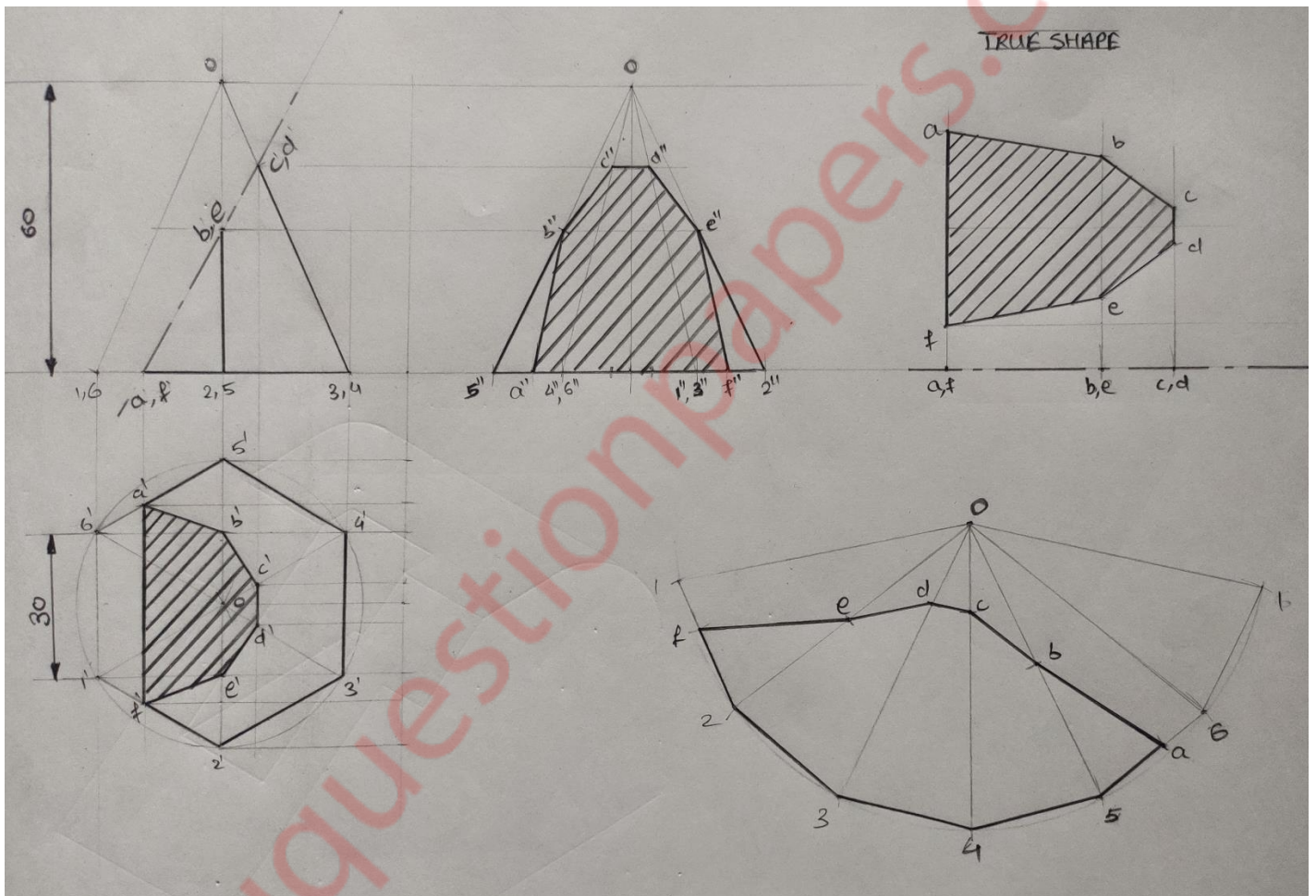

Q.6(a) The TV of 75mm long line AB measures 60mm. Point A is 15 mm below HP and 50mm in front of VP. Point B is 15mm in front of VP and above HP. Draw projections of line and determine its inclination with HP and VP. [08]

Sol:

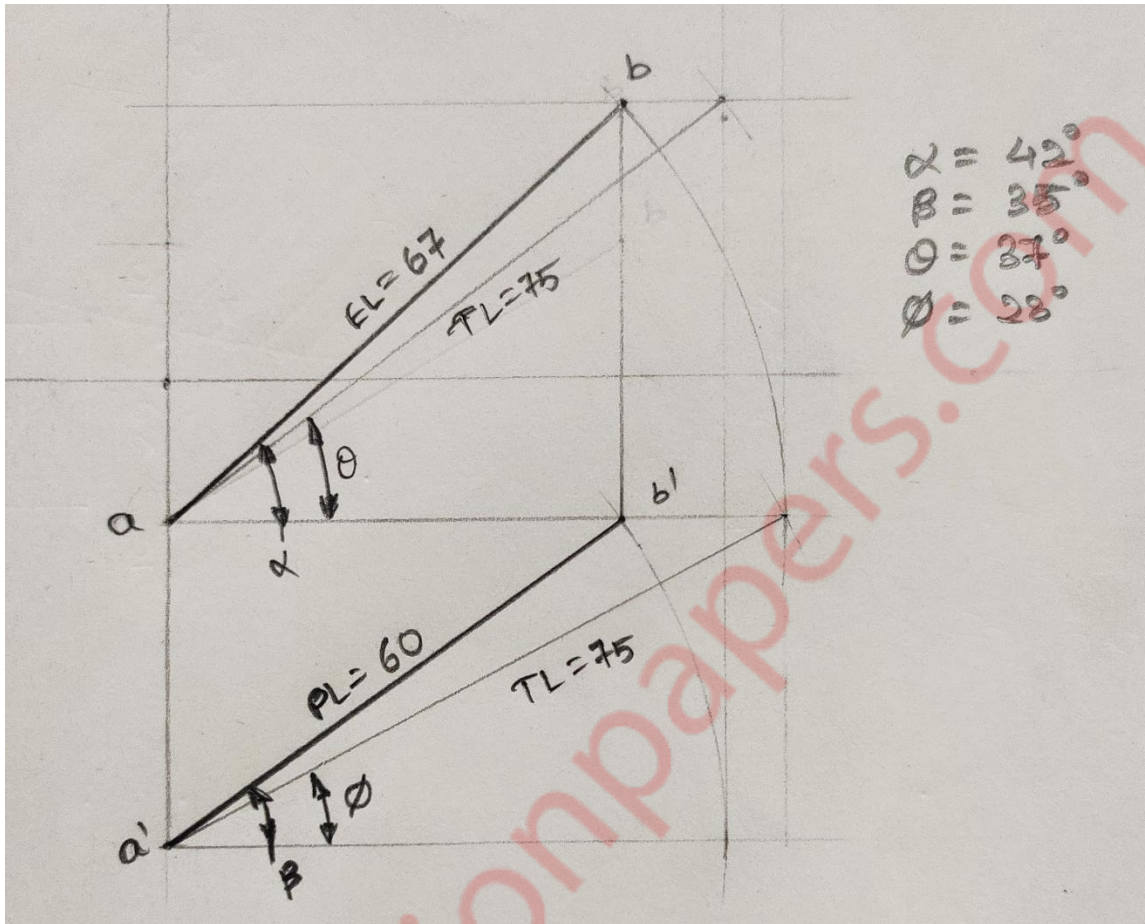

Q.6.(b) Front view and side view of an object are shown in figure, draw an isometric view [07]

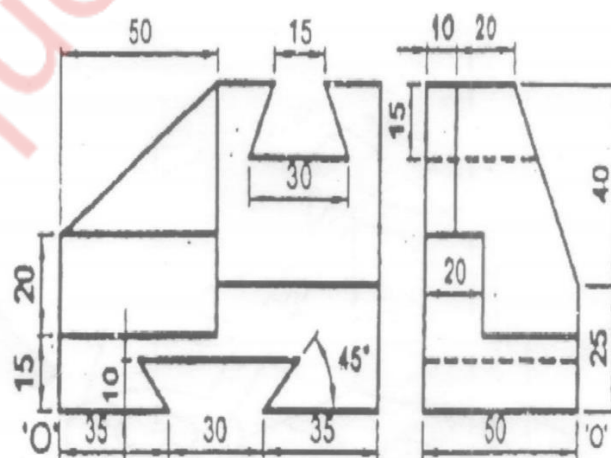

Sol:

