

# Engineering Drawing

*DEC, 2017*

Q1 a] An inelastic string 100 mm long is wound around a disc of 40 mm diameter. Trace the path of free end of string and name the curve.

06 M

Involute Curve

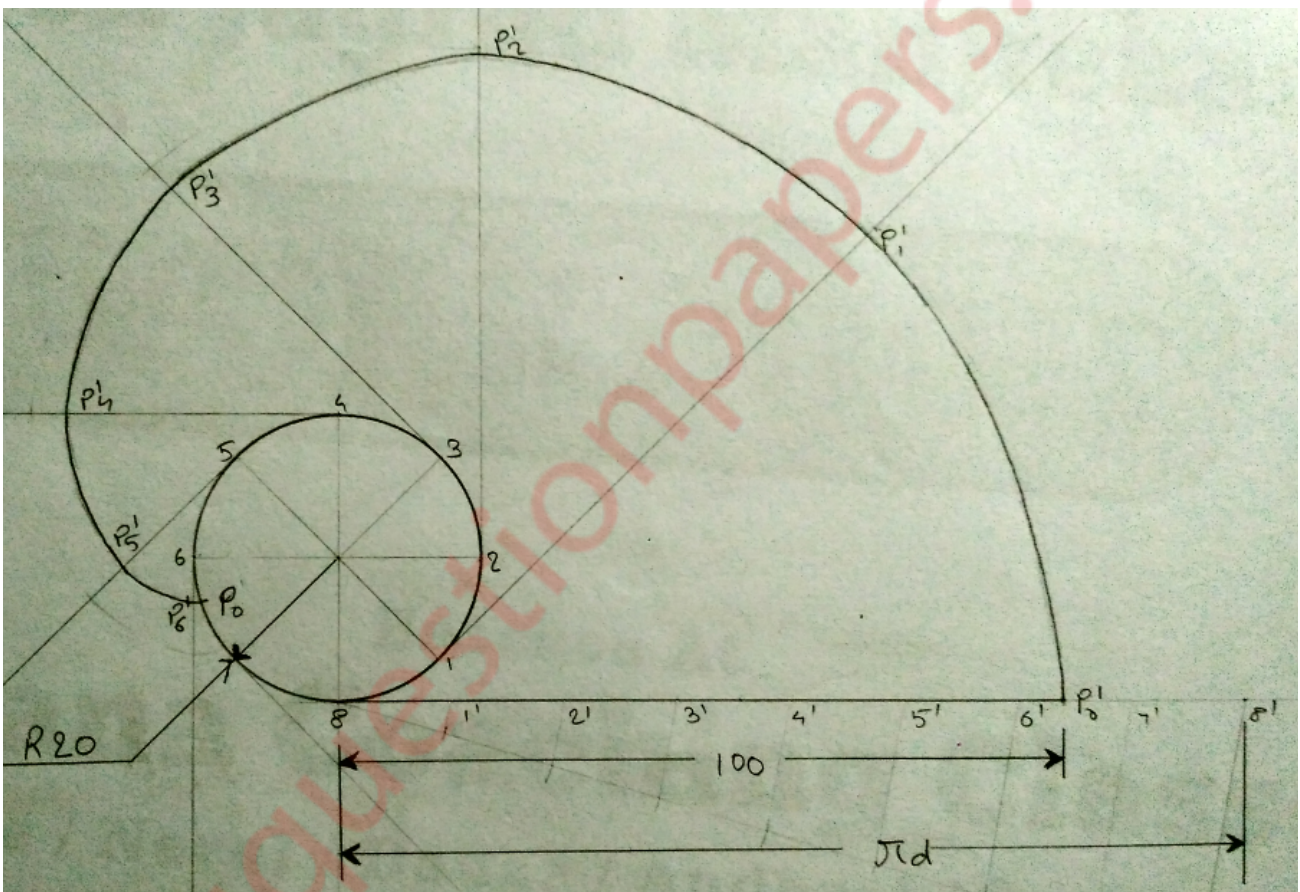

Q1 b] For the object shown in figure draw the following views -

09 M

- i) Front view in the direction of arrow X.
- ii) Top view.

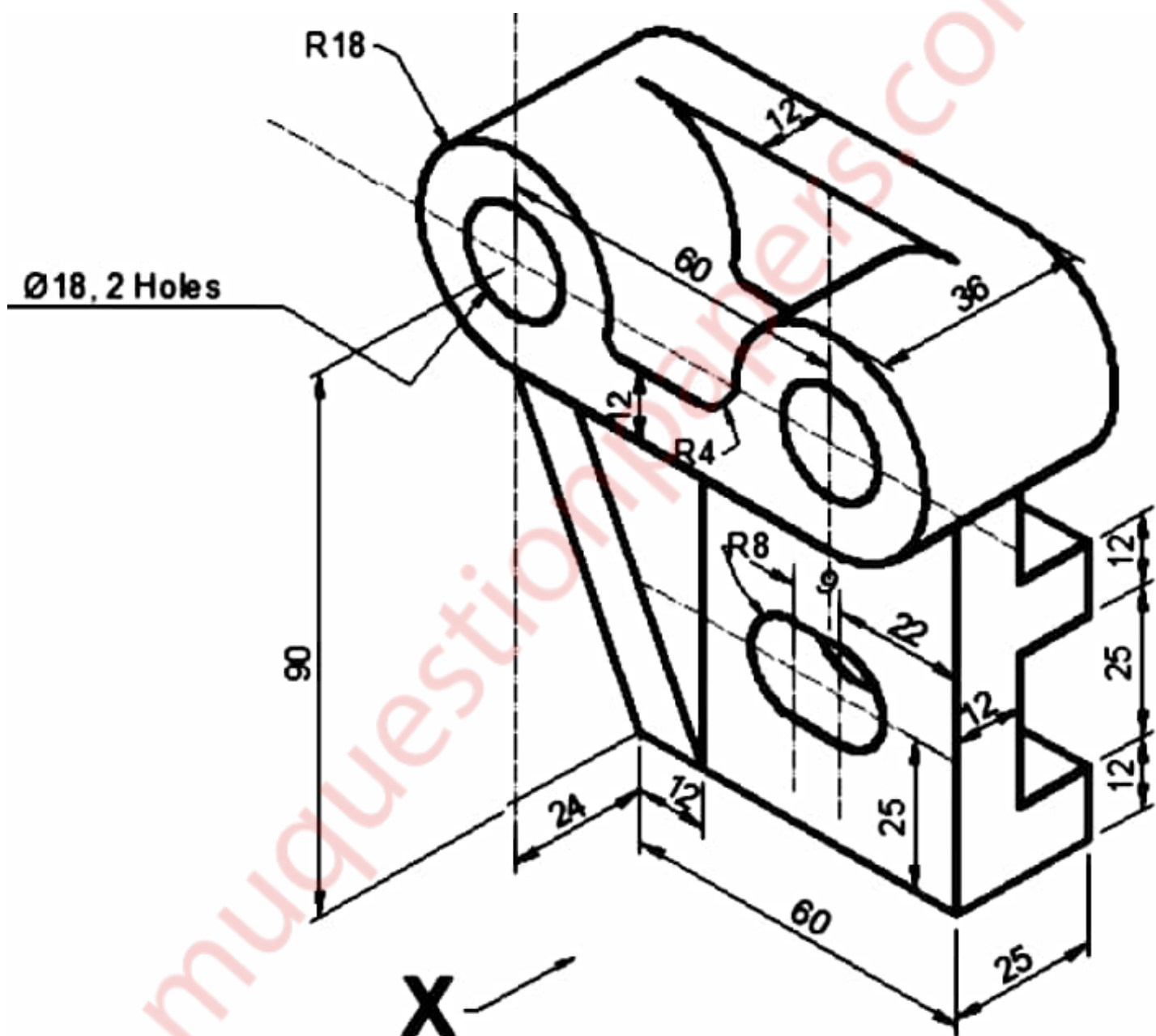

2 HOLES R9

R18

60

12

108

72

16

25

36

96

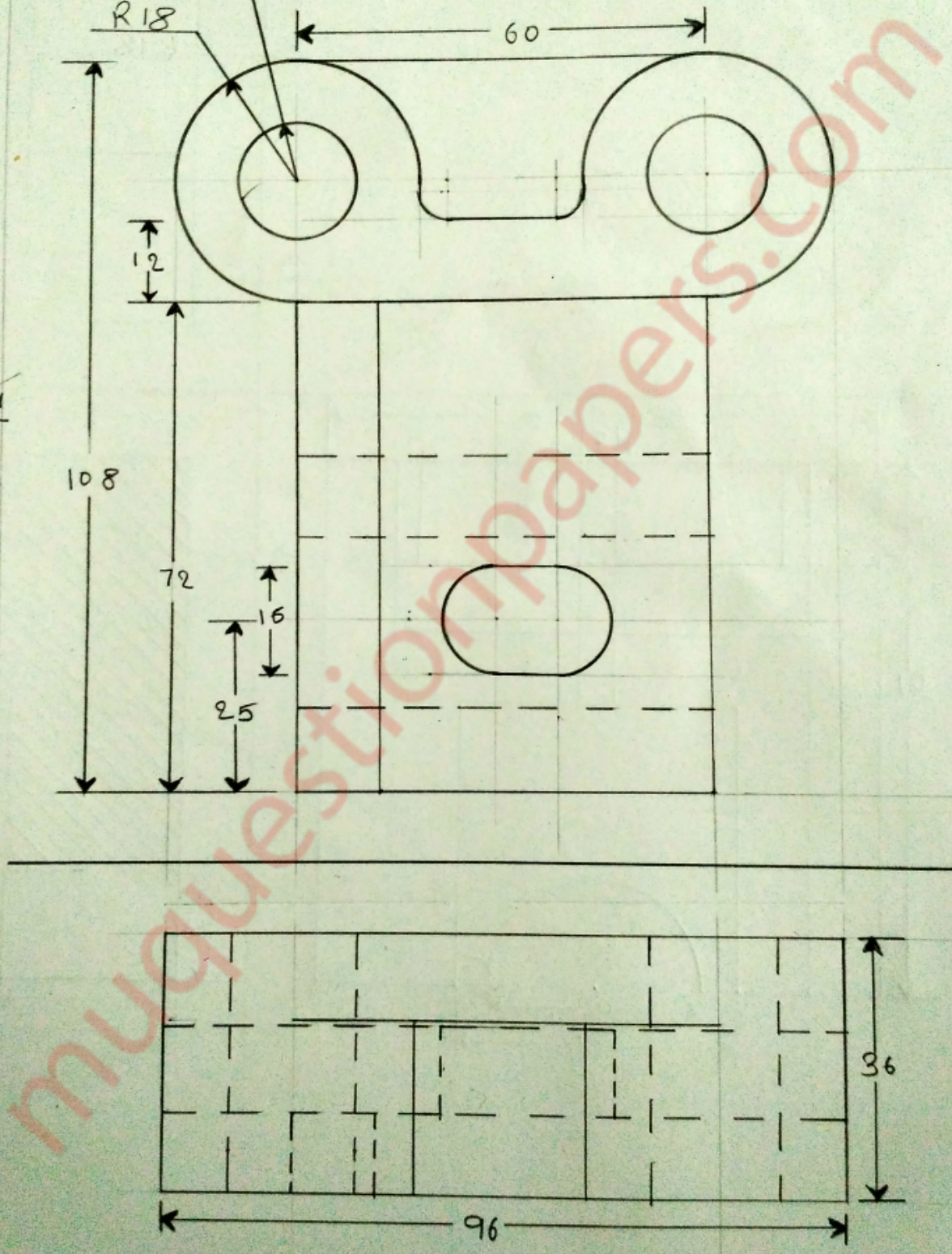
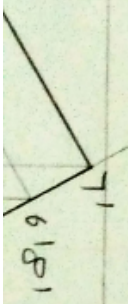

Q2] For the object shown in figure draw the following views - 15 M

- i) Sectional front view along section A-A.
- ii) Side view from left.
- iii) Top view.
- iv) Insert the major dimensions.

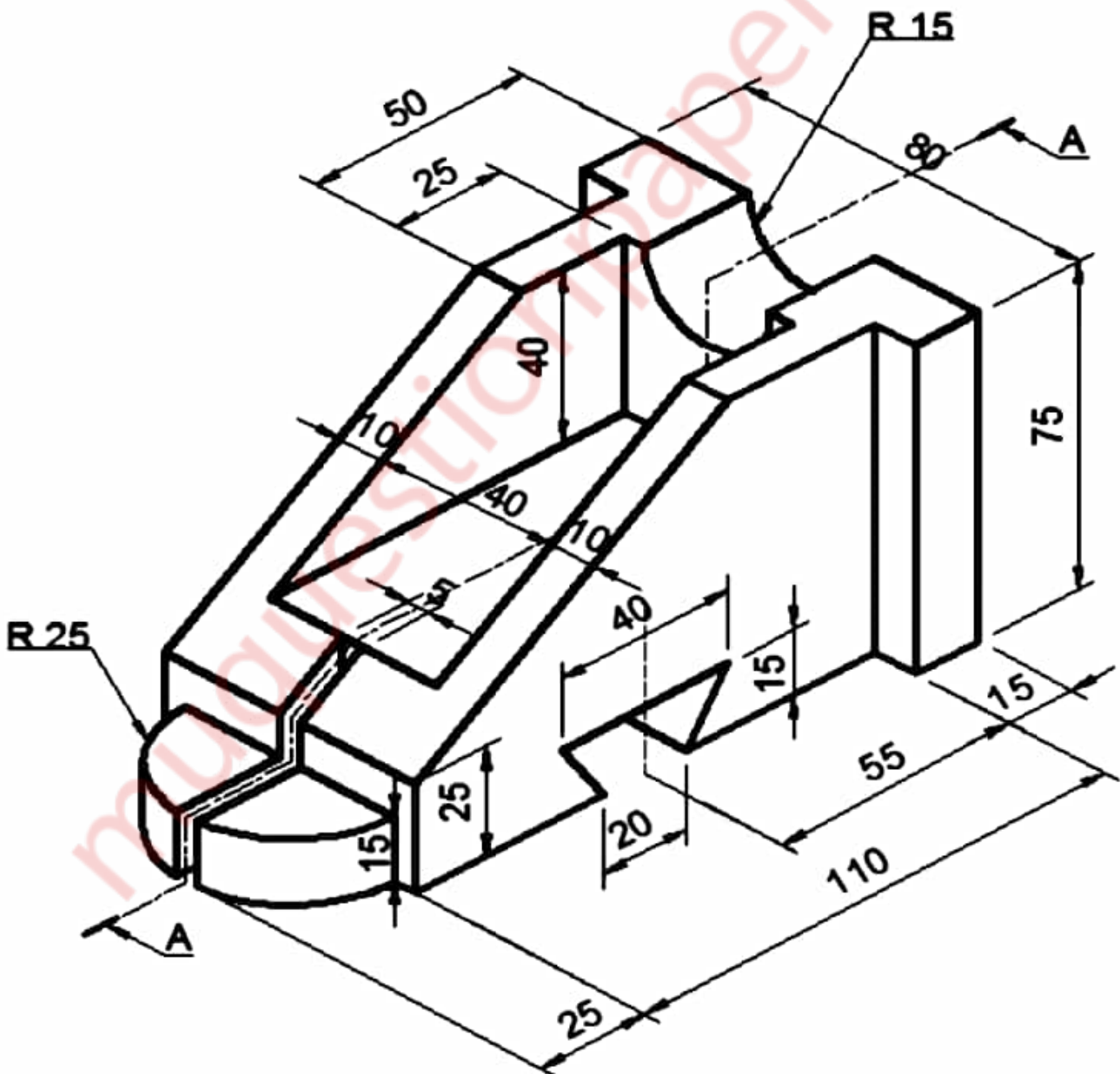

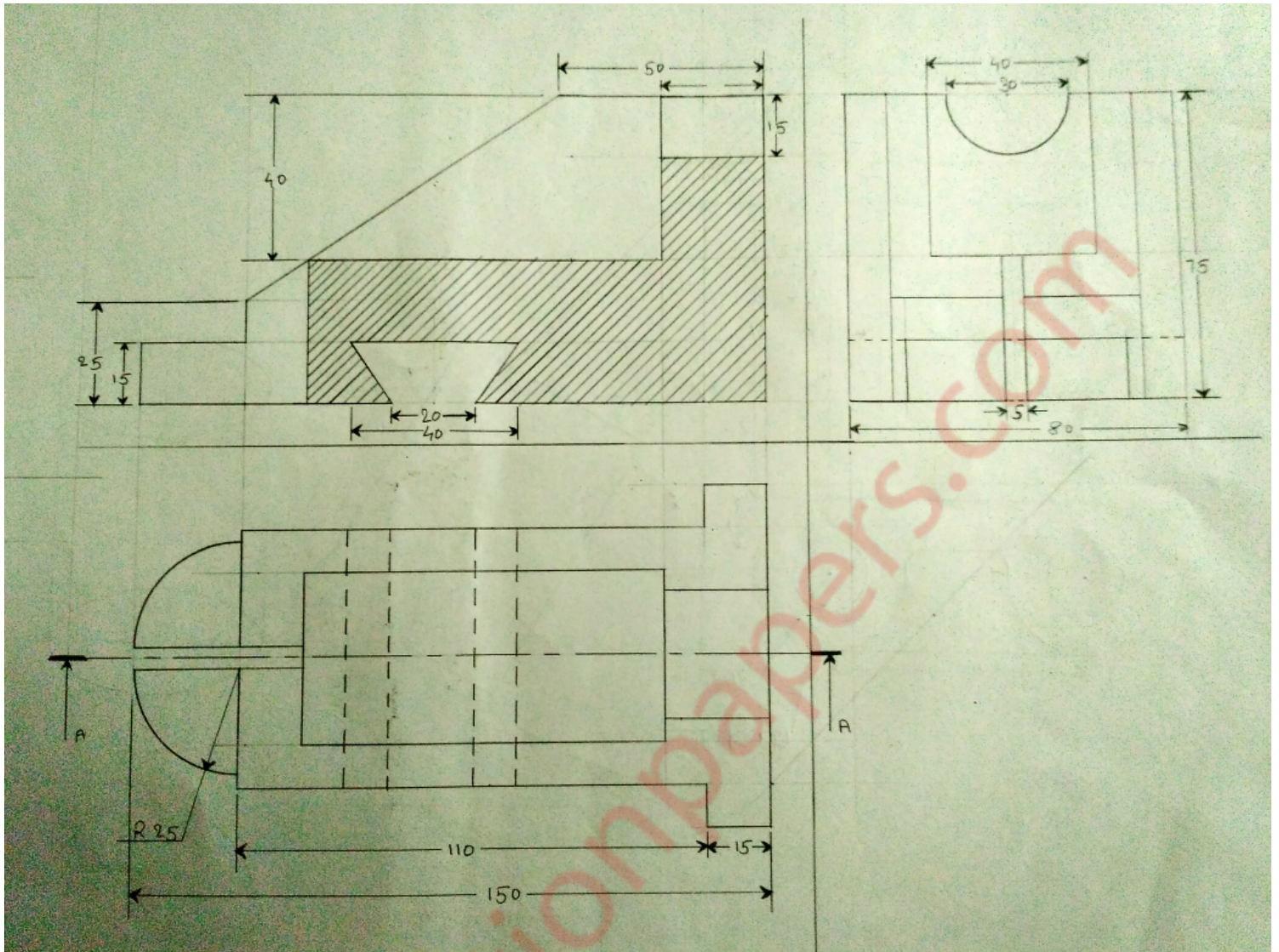

Q3] A square pyramid side of base 40 mm and axis length 60 mm has one of its side of base in the HP. The axis of the solid is inclined to the HP at an angle  $30^\circ$  and top view of the axis is inclined at an angle  $45^\circ$  with the VP. Draw its projection when the apex is away from the observer. 15 M

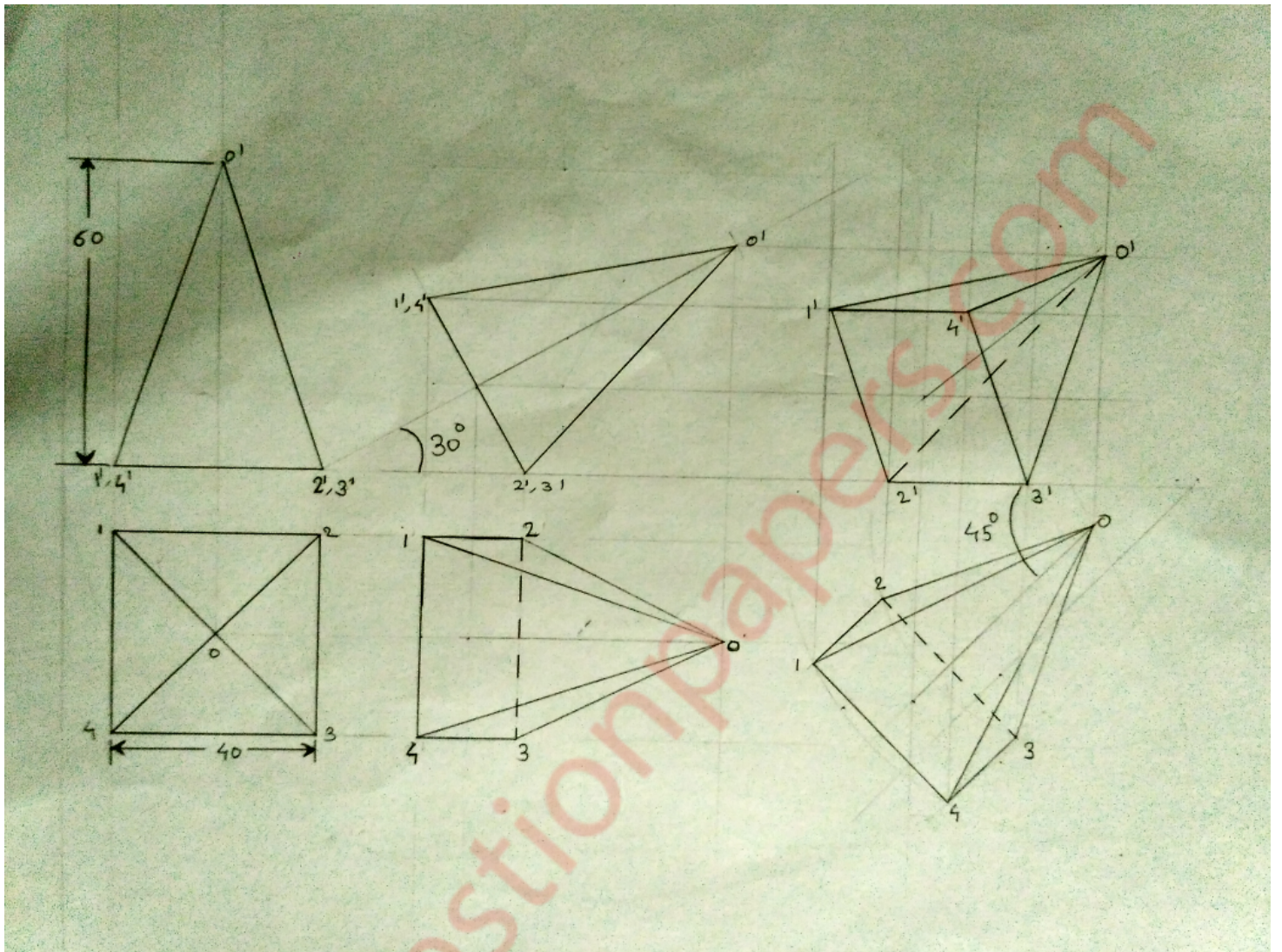

Q4 a] A right circular cylinder diameter of base 50 mm and axis height 70 mm has one of the circumference point of base in the HP, such that its axis is inclined at  $30^\circ$  to the HP. Draw its projections. 06 M

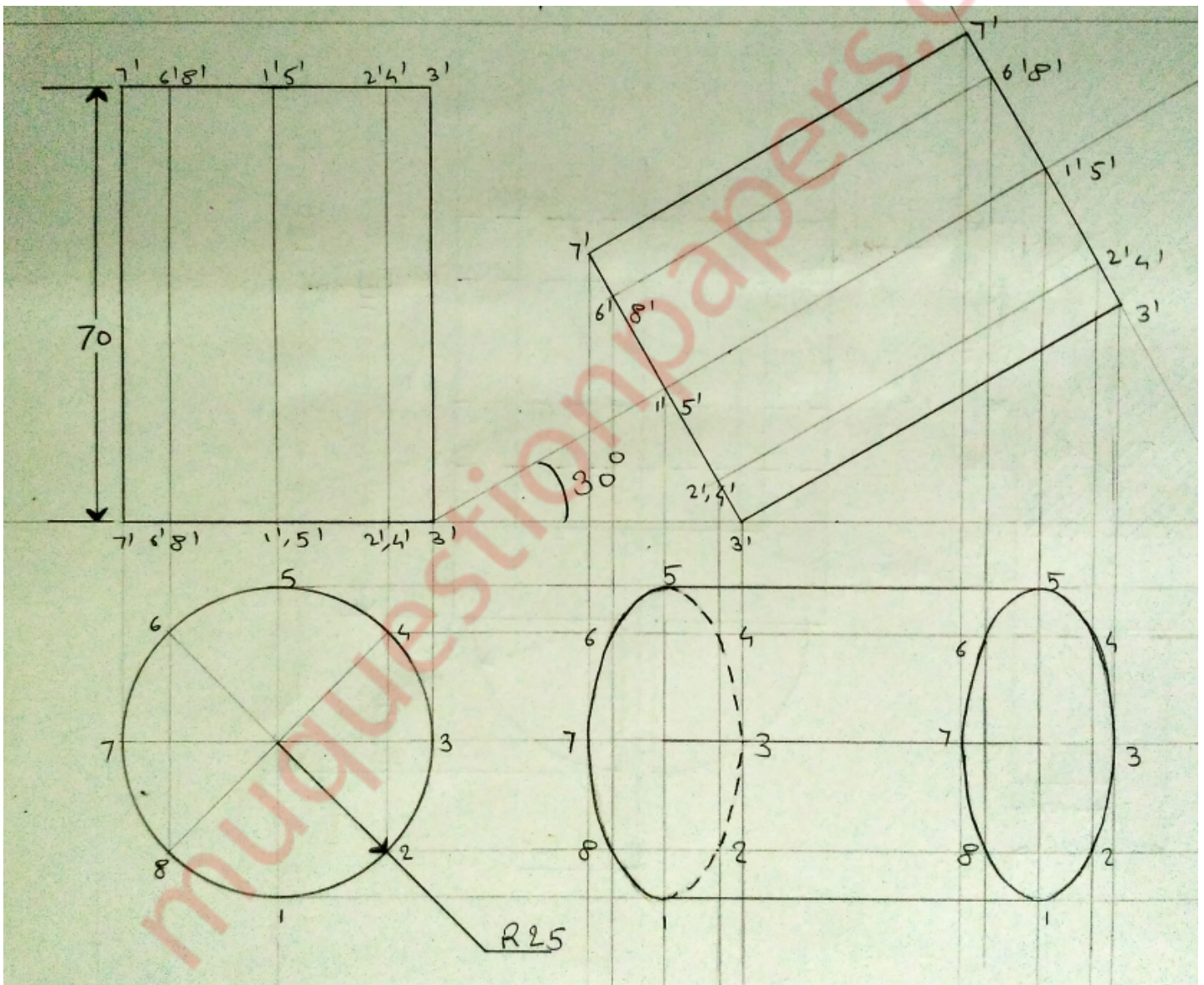



Q4 b) Figure shows two views of an object. Draw its isometric view. 09 M

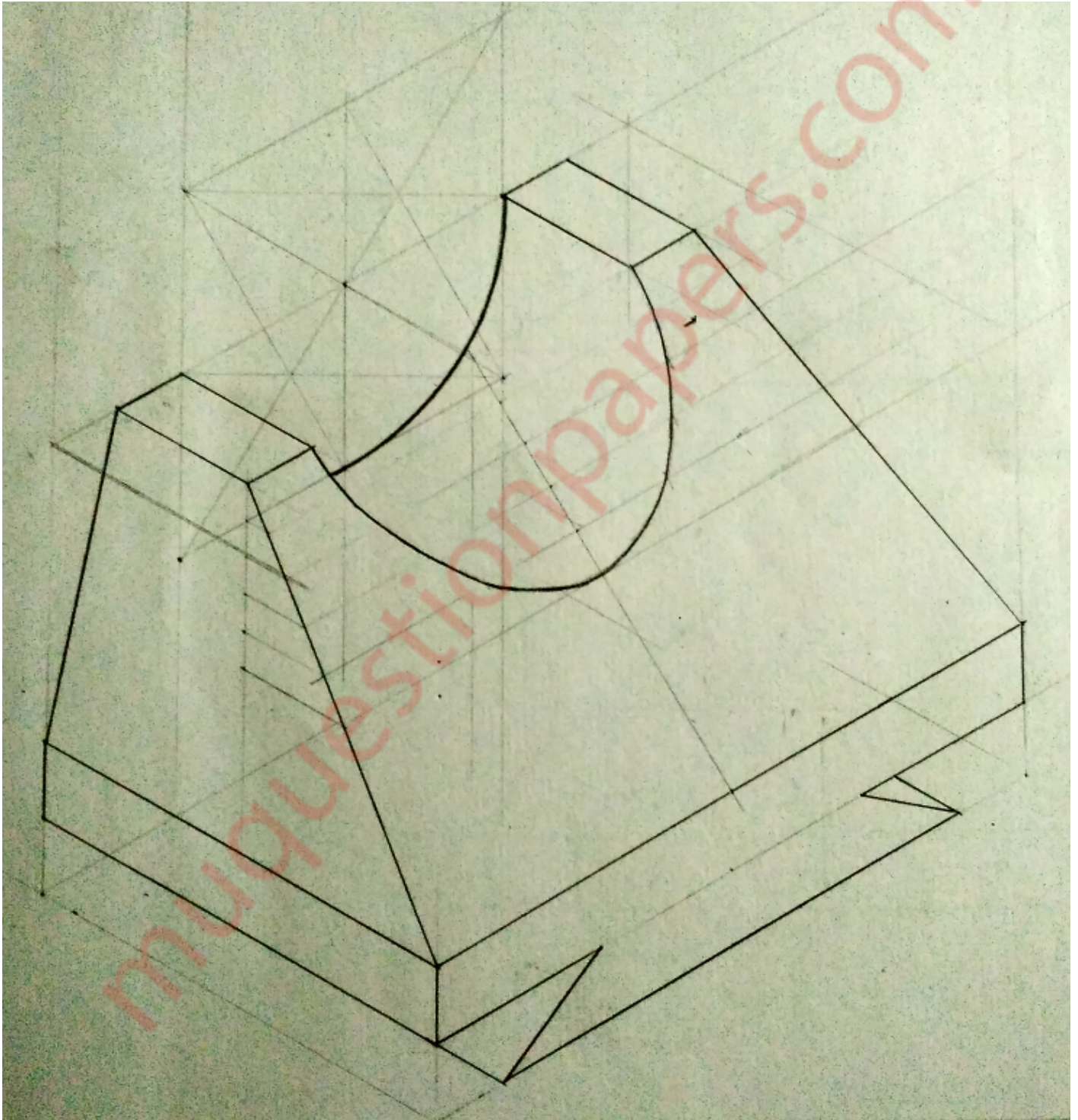

Q5] A cone of base 70 mm diameter and axis 90 mm long is resting on its base on HP. It is cut by a section plane perpendicular to the VP and parallel to and 15 mm away from one of its end generators. Draw the sectional top view, front view and sectional side view. Also draw the true shape of the section. Also draw the development of lateral surface of cone. 15 M

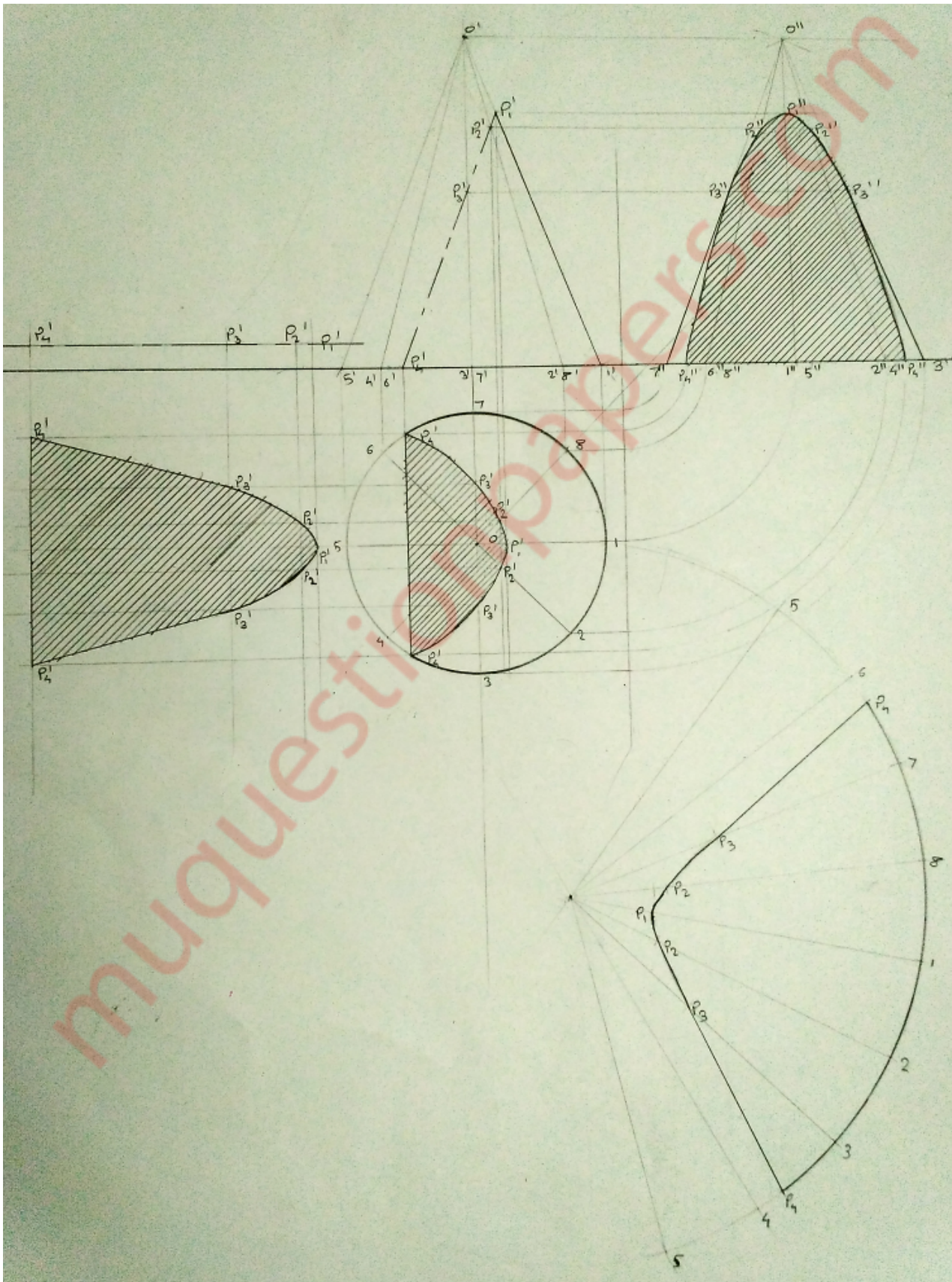

Q6 a] A straight line PQ has its end point P 10 mm above HP and 15 mm in front of the VP. The line 50 mm long and its front and top views are inclined at an angle of  $60^\circ$  and  $45^\circ$  respectively. Draw the projections of line PQ and find its inclinations with the HP and VP.

09 M

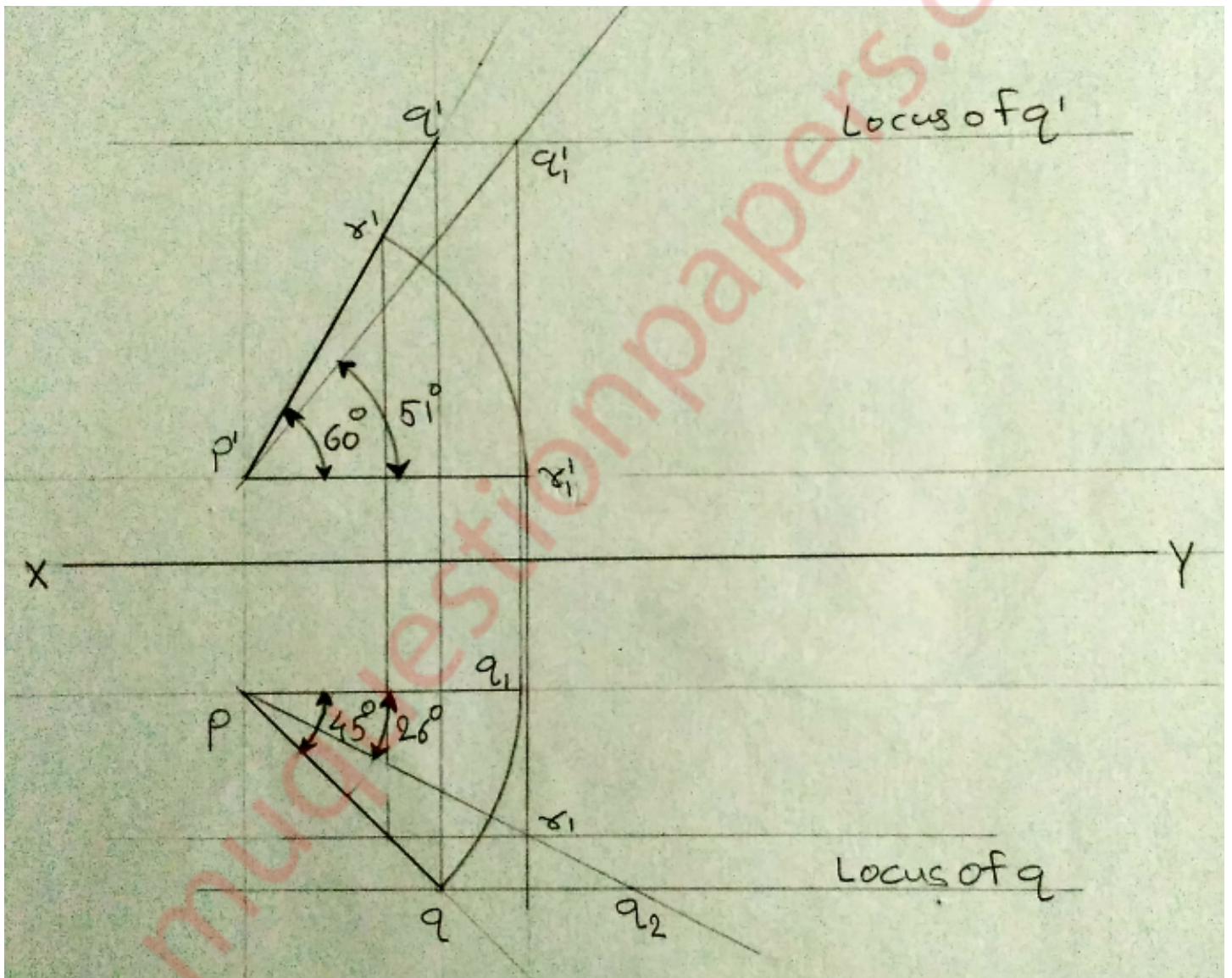

Q6 b] Figure shows two views of an object. Draw its isometric view with 'O' as origin.

06 M

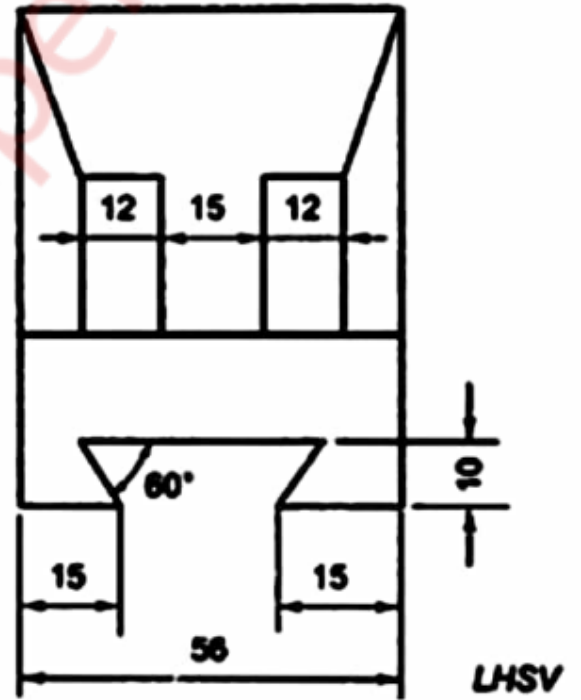
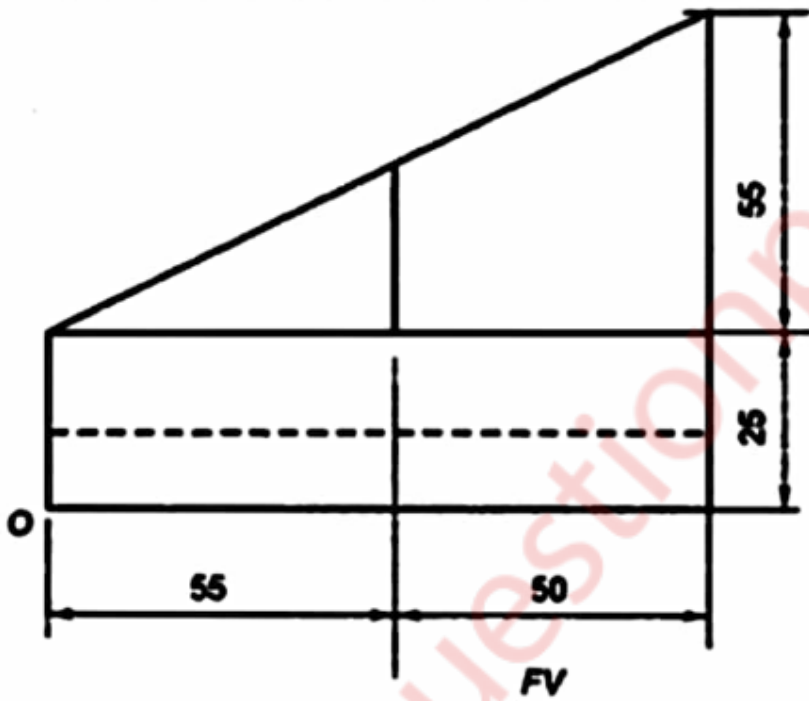

\*\*\*\*

