

BEE SOLUTION OF QUESTION PAPER

CBCGS (DEC-2019 Rev)

Q1. Answer any Five.

(i) Find the value of R_3 in the figure given below by applying Kirchhoff's Laws. (4)

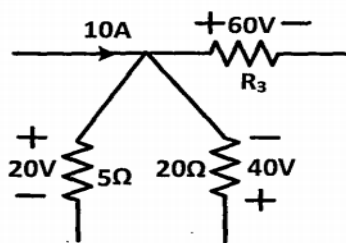

SOLUTION: Apply Kirchhoff's current law (KCL)

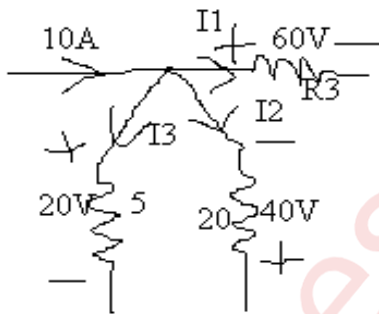

$$I_1 + I_2 + I_3 - 10 = 0$$

$$\frac{60}{R_3} - \frac{40}{20} + \frac{20}{5} = 10$$

$$\frac{60}{R_3} - 2 + 4 = 10$$

$$R_3 = 7.5\Omega$$

(ii) Briefly describe the operation of any one type of stepper motor.

SOLUTION: Permanent magnet stepper motor: (4)

The stepper motor rotor is a permanent magnet when the current flows through the stator winding, the stator winding to produce a vector magnetic field. The magnetic field drives the rotor to rotate by an angle so that the pair of magnetic fields of the rotor and the magnetic field direction of the stator are consistent. When the stator's vector magnetic field is rotated by an angle, the rotor also rotates with the magnetic field at an angle. Each time an electrical pulse is an input, the motor rotates one degree further. The angular displacement it outputs is proportional to the number of pulses input and the speed is proportional to the pulse frequency. Change the order of winding power, the motor will reverse. Therefore, it can control the rotation of the stepping motor by controlling the number of pulses, the frequency and the electrical sequence of each phase winding of the motor.

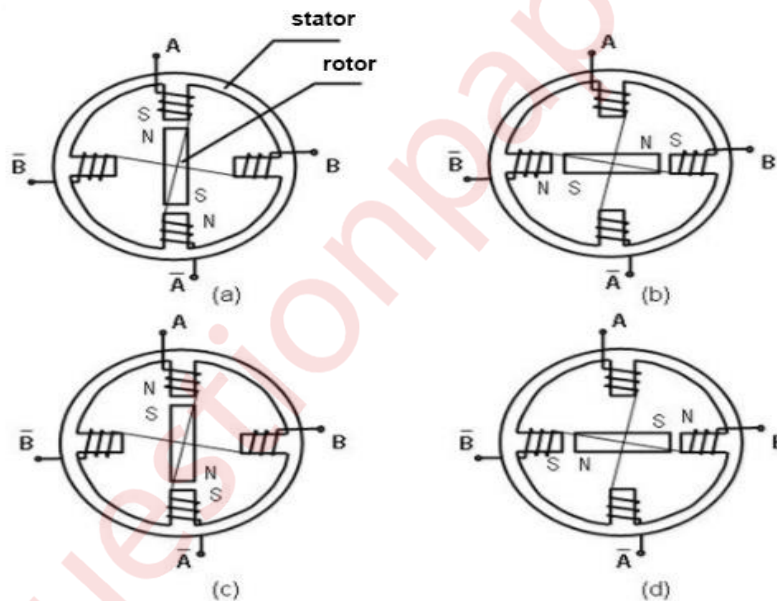

(iii) Two pure circuit elements in a series connection have the following current and applied voltage: $V(t)=150\sin(500t+10)v$, $i(t)=13.42\sin(500t-53.3)A$. Find the supply frequency(in Hz) and value of circuit elements. (4)

SOLUTION: Given $V(t)=150\sin(500t+10)v$ and $i(t)=13.42\sin(500t-53.4)A$

$$\omega=500=2\pi f \quad \text{therefore frequency is } f=\frac{500}{2\pi} = 79.577\text{Hz}$$

We can see that the current lagging the voltage,

$$V(t) = 150\angle 10 \quad i(t) = 13.42\angle -53.4$$

$$\text{Impedance } Z = (R + jX_L) = \frac{V(t)}{i(t)} = \frac{150\angle 10}{13.42\angle -53.4} = (5 + j10)$$

$$\text{Resistance} = R = 5\Omega$$

$$\text{And } X_L = 10 \quad \omega L = 10, \quad \text{therefore Inductance } L = \frac{10}{500} = 20\text{mH.}$$

(iv) A three phase, three wire, 100V system supplies a balanced delta-connected load with per phase impedance of $20\angle 45$ ohms. Determine the line current drawn and active power taken by the load. (4)

SOLUTION: Given $Z = 20\angle 45$

Since it is a delta connected load therefore,

$$V_{ph} = V_L = 100V$$

$$I_{ph} = \frac{V_{ph}}{Z} = \frac{100}{20\angle 45} = 3.535\angle -45 \text{ A}$$

$$\text{Line Current } I_L = \sqrt{3} \times I_{ph} = 6.12\angle -45 \text{ A}$$

$$\text{Active Power } P = \sqrt{3} V_L I_L \cos(-45) = 749.54 \text{ W}$$

(v) Draw the phasor diagram of a single phase non ideal transformer feeding resistive load. (4)

SOLUTION:

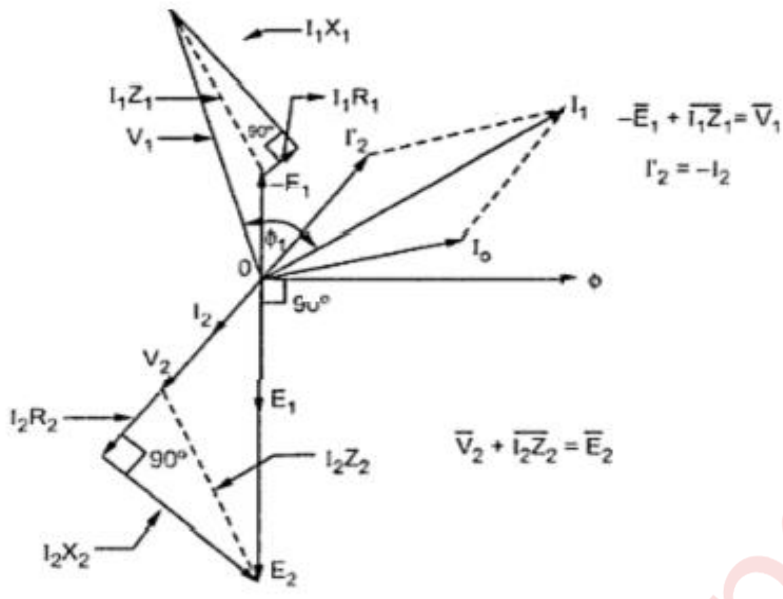

(vi) Single phase induction motor is not self-starting . State true or false and justify your answer. (4)

SOLUTION: In induction machine a rotating magnetic field is required to produce torque.

A rotating magnetic field can produced if we have balanced three phase supply and each phase is electrically spaced 120 to each other OR we have required minimum two phase

BUT in single phase induction motor there is single phase supply to the stator of motor , A SINGLE PHASE SUPPLY CANNOT PRODUCE A ROTATING MAGNETIC FIELD BUT IT PRODUCE A PULSATING MAGNETIC FIELD WHICH DOES NOT ROTATE.

Due to this pulsating magnetic field torque cannot produce so motor is not self-start.

we can make single phase induction motor self-start by split single phase supply into two phase supply with the help of auxilliary winding.

Q2. (A) Find the current through 5Ω (I_x) using superposition theorem without using source transformation . (10)

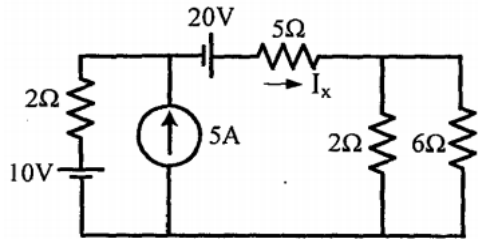

SOLUTION: (i) Only 10V voltage source acting alone:

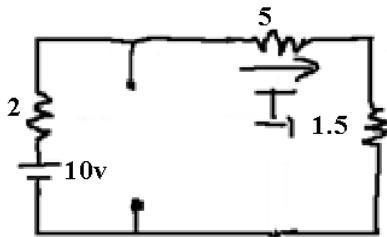

Solving parallel resistors(2//6) $\frac{2 \times 6}{2+6} = 1.5\Omega$

$$I_1 = \frac{10}{2+5+1.5} = 1.176A$$

(i) Only 10A current source acting alone:

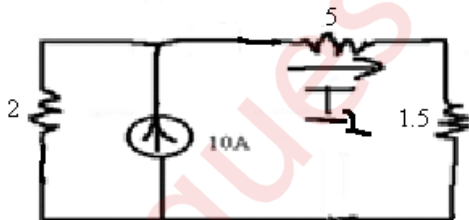

Using current division rule: $I_2 = \frac{(2) \times 10}{(2+1.5+5)} = 2.352A$

(i) Only 20v voltage source acting alone:

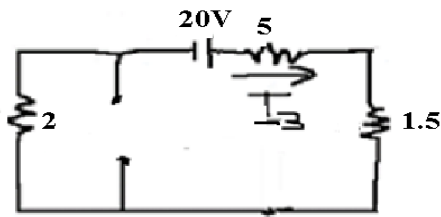

$$I_3 = \frac{20}{1.5+5+2} = 2.352A$$

By superposition theorem the total current through 5Ω resistor by 10v, 10A & 20v source will be,

$$I_X = I_1 + I_2 + I_3 = 1.176+2.352+2.352 = 5.88A$$

(B) State and prove Maximum Power Transfer Theorem. (5)

SOLUTION: The **maximum power transfer theorem** states that, to obtain **maximum** external **power** from a source with a finite internal resistance, the resistance of the load must equal the resistance of the source as viewed from its output terminals.

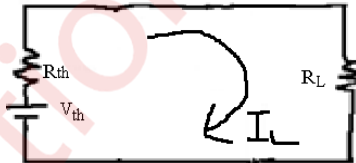

Proof: Power delivered to the load resistance,

$$P_L = I_L^2 \times R_L$$

$$= \left[\frac{V_{Th}}{R_{Th} + R_L} \right]^2 \times R_L$$

To find the maximum power, differentiate the above expression with respect to resistance R_L and equate it to zero. Thus,

$$\frac{dP(R_L)}{dR_L} = V_{Th}^2 \left[\frac{(R_{Th} + R_L)^2 - 2R_L \times (R_{Th} + R_L)}{(R_{Th} + R_L)^4} \right] = 0$$

$$\Rightarrow (R_{Th} + R_L) - 2R_L = 0$$

$$\Rightarrow R_L = R_{Th}$$

The maximum power delivered to the load is,

$$P_{\max} = \left[\frac{V_{Th}}{R_{Th} + R_L} \right]^2 \times R_L \Big|_{R_L = R_{Th}}$$

$$= \frac{V_{Th}^2}{4 R_{Th}}$$

Thus in this case, the maximum power will be transferred to the load when load resistance is just equal to internal resistance of the battery.

(C) Plot the variation of current, impedance, resistance, inductive reactance and capacitive reactance when supply frequency is varied in R-L-C series circuit. (5)

SOLUTION:

(i) Variation of current with frequency:

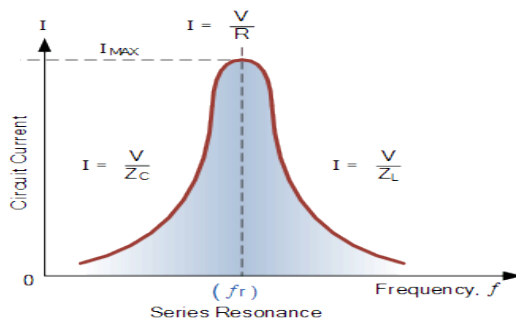

(ii) Variation of impedance with frequency:

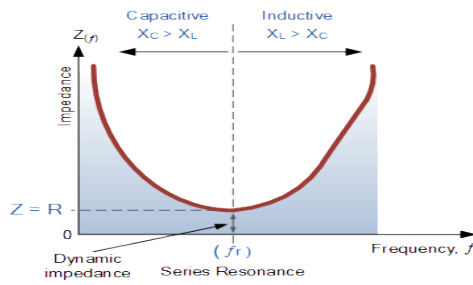

(iii) Variation of resistance with frequency:

Resistance is independent of frequency, so it remains constant with change in frequency.

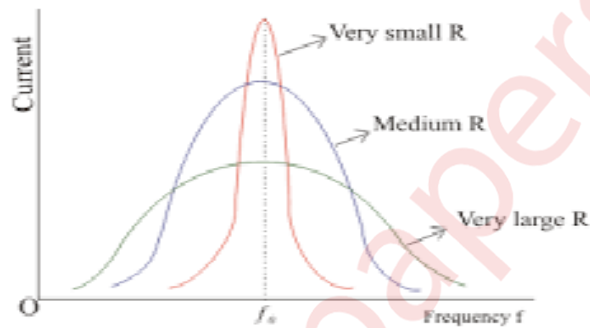

(iv) Variation of inductive reactance with frequency:

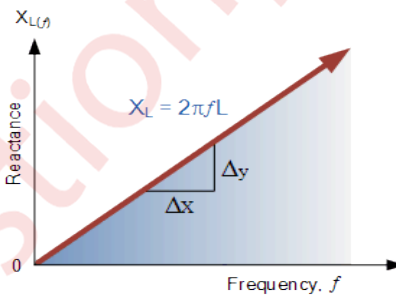

(v) Variation of capacitive reactance with frequency:

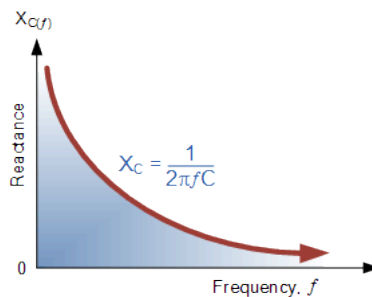

Q3. (A) The open Circuit(OC) and Short Circuit(SC) tests on a 5KVA, 200/400 V, 50 Hz single phase transformer gave the following results:

OC: 200V, 1A, 100W(lv side), SC: 15V, 10A, 85W(hv side). Draw the equivalent circuit referred to primary and put all values. (10)

SOLUTION:

From OC test,

$$\text{No load(or OC) power factor } \cos\phi_o = \frac{100}{200 \times 1} = 0.5$$

$$\phi_o = \cos^{-1}(0.5) = 60^\circ$$

$$\text{Hence, } \sin\phi_o = 0.866$$

$$\text{Magnetizing component, } I_{m1} = (I_o \times \sin\phi_o) = 1 \times 0.866 = 0.866\text{A}$$

$$\text{Core Loss component, } I_{c1} = (I_o \times \cos\phi_o) = 1 \times 0.5 = 0.5\text{A}$$

$$\text{Therefore Magnetizing Reactance } X_{m1} = \frac{V_o}{I_{m1}} = \frac{200}{0.866} = 230.94\Omega$$

$$\text{Resistance representing core loss } R_{c1} = \frac{V_o}{I_{c1}} = \frac{200}{0.5} = 400\Omega$$

From SC test,

$$W_{sc} = (I_{sc})^2 r_{e2}$$

$$r_{e2} = \frac{W_{sc}}{(I_{sc})^2} = \frac{15}{10 \times 10} = 0.15\Omega$$

$$\text{Now SC Impedance } Z_{sc} = \frac{V_{sc}}{I_{sc}} = \frac{15}{10} = 1.5\Omega$$

$$\text{Thus } x_{e2} = \sqrt{(Z_{sc})^2 - (r_{e2})^2} = \sqrt{(1.5)^2 - (0.15)^2} = \sqrt{2.25 - 0.0225} = 1.49\Omega$$

Now equivalent circuit referred to primary side,

$$\text{Turns ratio, } a = 200/400 = 0.5$$

$$r_{e1} = a^2 r_{e2} = 0.5^2 \times 0.15 = 0.0375\Omega$$

$$x_{e1} = a^2 x_{e2} = 0.5^2 \times 1.49 = 0.3725 \Omega$$

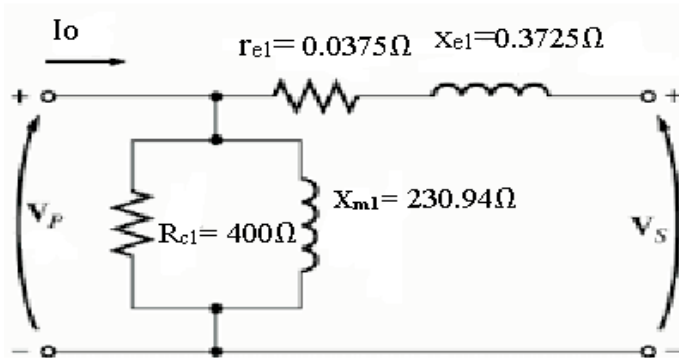

Equivalent circuit referred to primary side

(B) Derive the EMF equation of DC motor.

(5)

SOLUTION:

Let

Φ - flux/ pole in weber

Z – Total number of armature conductors.

P - Number of poles

A - Number of parallel paths in armature

N - Speed of armature in r.p.m

Flux cut by one conductor = $d\Phi = P\Phi$

Time taken to complete one revolution = $dt = 60/N$ seconds

Average induced E.M.F in one conductor = $e = P\Phi/dt$

$e = P\Phi N/60$ Volt

Number of conductors connected in series in each parallel path = Z/A

Average induced EMF across each parallel path that is across armature terminals,

$$E = e * Z/A$$

$$= (P\Phi N/60) * Z/A$$

$$E = (\Phi ZN/60) * P/A$$

For a wave wound machine $A = 2$

$$E = \Phi ZNP/120 \text{ Volt}$$

Lap wound machine $A = P$

$$E = \Phi ZN/60 \text{ Volt}$$

(C) Find the Root Mean Square Value (RMS) value of the following waveform. (5)

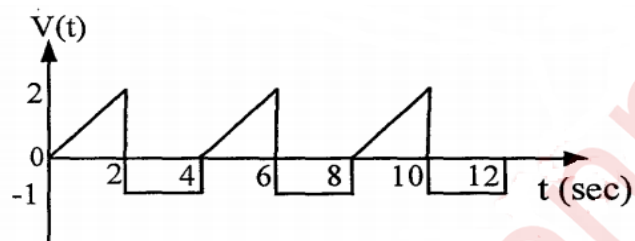

SOLUTION:

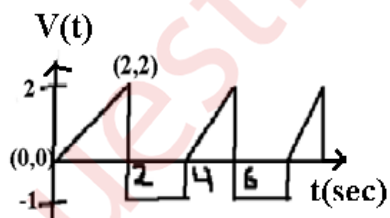

For triangular waveform slope of line $m = \frac{2}{2} = 1$

From $0 < t < 2$

$$Y = mx + c, V = 1t + 0 = t$$

From $2 < t < 4$

$$V = -1$$

$$\int_0^4 v^2(t) dt = \int_0^2 t^2 dt + \int_2^4 (-1)^2 dt = \left[\frac{t^3}{3} \right]_0^2 + [1]_2^4 = \left(\frac{8}{3} + 2 \right) = 4.67$$

$$V_{\text{rms}} = \sqrt{\frac{\text{Area of Waveform over full cycle}}{\text{Period of the waveform}}} = \sqrt{\frac{4.67}{4}} = \sqrt{1.167} = 1.08\text{V}$$

Q4. (A) With a neat circuit diagram and phasor diagram, prove that by two wattmeter method active power and reactive power of a three phase load can be measured. (10)

SOLUTION:

The connection diagram of a 3 phase balanced load connected as Star Connection is shown below.

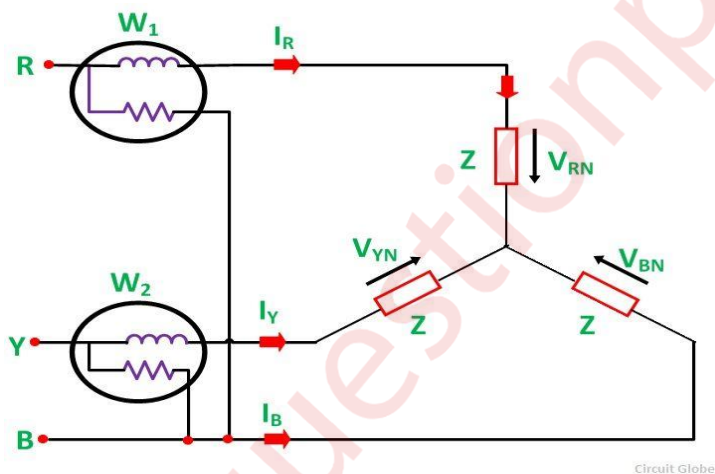

The load is considered as an inductive load, and thus, the phasor diagram of the inductive load is drawn below.

Current through the current coil of the Wattmeter, W_2 is given as

$$W_2 = I_Y$$

Potential difference across the Wattmeter, W_2 is

$$W_2 = V_{YB} = V_{RN} - V_{BN}$$

The phase difference V_{YB} and I_Y is $(30^\circ + \phi)$.

Therefore, the power measured by the Wattmeter, W_2 is given by the equation shown below.

$$W_2 = V_{YB} I_Y \cos (30^\circ + \phi)$$

Since, the load is in balanced condition, hence,

$$I_R = I_Y = I_B = I_L \text{ and}$$

$$V_{RY} = V_{YB} = V_{BR} = V_L$$

Therefore, the wattmeter readings will be

$$W_1 = V_L I_L \cos (30^\circ - \phi) \text{ and}$$

$$W_2 = V_L I_L \cos (30^\circ + \phi)$$

Now, the sum of two Wattmeter readings will be given as

$$W_1 + W_2 = [V_L I_L \cos (30^\circ - \phi) + V_L I_L \cos (30^\circ + \phi)]$$

$$W_1 + W_2 = V_L I_L [\cos 30^\circ \cos \phi + \sin 30^\circ \sin \phi + \cos 30^\circ \cos \phi - \sin 30^\circ \sin \phi]$$

$$W_1 + W_2 = V_L I_L (2 \cos 30^\circ \cos \phi)$$

$$W_1 + W_2 = V_L I_L (2 \frac{\sqrt{3}}{2} \cos \phi)$$

$$W_1 + W_2 = \sqrt{3} V_L I_L \cos \phi = P \dots\dots\dots(1)$$

The above equation (1) gives the Active power absorbed by a 3 phase balanced load.

As we know that,

$$W_1 + W_2 = \sqrt{3} V_L I_L \cos \phi$$

Now,

$$W_1 - W_2 = [V_L I_L \cos (30^\circ - \phi) - V_L I_L \cos (30^\circ + \phi)]$$

$$W_1 - W_2 = V_L I_L [\cos 30^\circ \cos \phi + \sin 30^\circ \sin \phi - \cos 30^\circ \cos \phi + \sin 30^\circ \sin \phi]$$

$$W_1 - W_2 = 2 V_L I_L \sin 30^\circ \sin \phi$$

$$W_1 - W_2 = V_L I_L \sin \phi \dots\dots\dots(2)$$

Determination of Reactive Power by Two Wattmeter Method

To get the reactive power, multiply equation (2) by $\sqrt{3}$

$$\sqrt{3} (W_1 - W_2) = \sqrt{3} V_L I_L \sin \phi = P_r$$

Therefore, the Reactive Power is given by the equation shown below.

$$P_r = \sqrt{3} (W_1 - W_2)$$

(B) A sinusoidal voltage $v(t)=200\sin(\omega t)$ is applied to a series R-L-C circuit with $R=20\Omega$, $l=100\text{mH}$, and $C=10\mu\text{F}$. Find (i) the resonant frequency, (ii) RMS value of current at resonance (iii) Quality factor of the circuit, (iv) voltage across the inductor at resonance frequency and (v) phasor diagram at resonance. (10)

SOLUTION: $L=100\text{mH} = 100 \times 10^{-3} = 0.1\text{H}$

$$C=10\mu\text{F}=10 \times 10^{-6}=10^{-5}$$

(i) The resonant frequency $f_0 = \frac{1}{2\pi \sqrt{LC}} = \frac{1}{2\pi \sqrt{0.1 \times 10^{-5}}} = 159.15\text{Hz}$

(ii) At resonance $(X_L - X_C)^2 = 0$, $Z = \sqrt{R^2 + (X_L - X_C)^2} = R$

$$I_{\text{rms}} = \frac{V}{Z} = \frac{200}{20} = 10\text{A}$$

(iii) Q factor = $\frac{W \times L}{R} = \frac{2\pi \times 159.15 \times 0.1}{20} = 5$

(iv) At resonance, the voltage across the inductor is,

$$V_L = I_{\text{rms}} X_L = (10) \times (2\pi \times 159.15) \times (0.1) = 999.96\text{V}$$

(v) At resonance $X_L = X_C$ and $V_L = V_C = 999.96\text{V}$ And circuit becomes Resistive . And phase difference between voltage and current will be zero i.e

$(\phi = 0)$ such that $V(t) = V_T = V_R = 200\text{V}$.

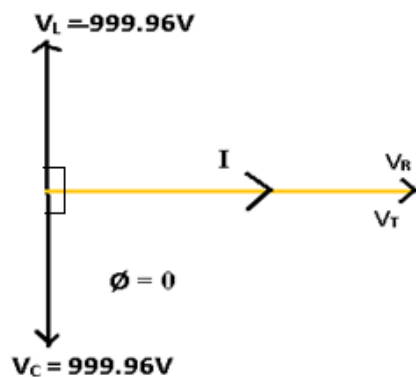

Q5. (A) Derive the transformation formula to convert a delta network of resistors to an equivalent star network and star network of resistors to an equivalent delta network. (10)

SOLUTION: Delta To Star Conversion:

The replacement of delta or mesh by equivalent star connection is known as **delta – star transformation**. The two connections are equivalent or identical to each other if the impedance is measured between any pair of lines. That means, the value of impedance will be the same if it is measured between any pair of lines irrespective of whether the delta is connected between the lines or its equivalent

star is connected between that lines.

DELTA AND STAR CONNECTED RESISTORS

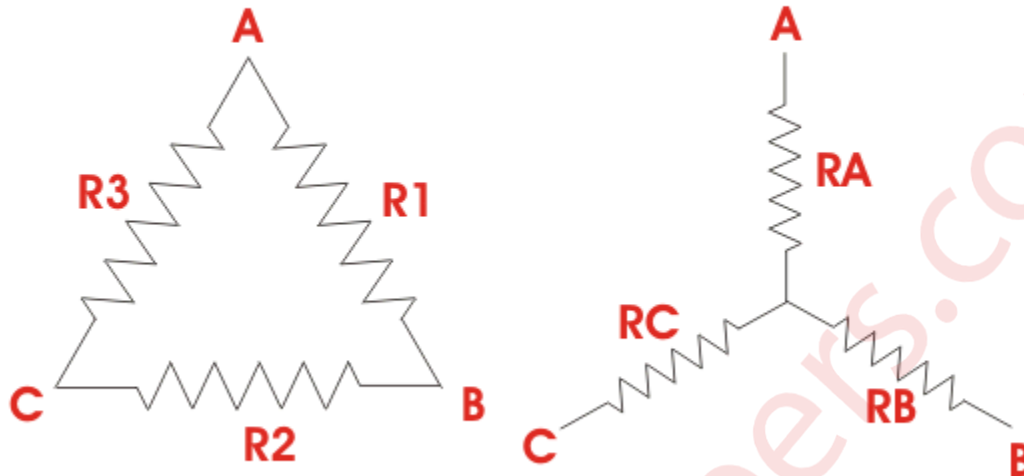

Consider a delta system that's three corner points are A, B and C as shown in the figure. Electrical resistance of the branch between points A and B, B and C and C and A are R_1 , R_2 and R_3 respectively.

$$R_{AB} = R_1 \parallel (R_2 + R_3) = \frac{R_1 \cdot (R_2 + R_3)}{R_1 + R_2 + R_3}$$

Now, one star system is connected to these points A, B, and C as shown in the figure. Three arms R_A , R_B and R_C of the star system are connected with A, B and C respectively. Now if we measure the resistance value between points A and B, we will get,

$$R_{AB} = R_A + R_B$$

Since the two systems are identical, resistance measured between terminals A and B in both systems must be equal.

$$R_A + R_B = \frac{R_1 \cdot (R_2 + R_3)}{R_1 + R_2 + R_3} \dots\dots\dots(i)$$

Similarly, resistance between points B and C being equal in the two systems,

$$R_B + R_C = \frac{R_2 \cdot (R_3 + R_1)}{R_1 + R_2 + R_3} \dots\dots\dots(ii)$$

And resistance between points C and A being equal in the two systems,

$$R_C + R_A = \frac{R_3 \cdot (R_1 + R_2)}{R_1 + R_2 + R_3} \dots\dots\dots (iii)$$

Adding equations (I), (II) and (III) we get,

$$2(R_A + R_B + R_C) = \frac{2 \cdot (R_1 \cdot R_2 + R_2 \cdot R_3 + R_3 \cdot R_1)}{R_1 + R_2 + R_3}$$
$$R_A + R_B + R_C = \frac{R_1 \cdot R_2 + R_2 \cdot R_3 + R_3 \cdot R_1}{R_1 + R_2 + R_3} \dots\dots\dots (iv)$$

Subtracting equations (I), (II) and (III) from equation (IV) we get,

$$R_A = \frac{R_3 \cdot R_1}{R_1 + R_2 + R_3} \dots\dots\dots (v)$$

$$R_B = \frac{R_1 \cdot R_2}{R_1 + R_2 + R_3} \dots\dots\dots (vi)$$

$$R_C = \frac{R_2 \cdot R_3}{R_1 + R_2 + R_3} \dots\dots\dots (vii)$$

For star – delta transformation we just multiply equations (v), (VI) and (VI), (VII) and (VII), (V) that is by doing (v) × (VI) + (VI) × (VII) + (VII) × (V) we get,

$$R_A R_B + R_B R_C + R_C R_A = \frac{R_1 R_2^2 R_3 + R_1 R_2 R_3^2 + R_1^2 R_2 R_3}{(R_1 + R_2 + R_3)^2}$$

$$R_A R_B + R_B R_C + R_C R_A = \frac{R_1 R_2^2 R_3 + R_1 R_2 R_3^2 + R_1^2 R_2 R_3}{(R_1 + R_2 + R_3)^2}$$

$$= \frac{R_1 R_2 R_3 (R_1 + R_2 + R_3)}{(R_1 + R_2 + R_3)^2}$$

$$= \frac{R_1 R_2 R_3}{R_1 + R_2 + R_3} \dots\dots (viii)$$

Now dividing equation (VIII) by equations (V), (VI) and equations (VII) separately we get,

$$R_2 = \frac{R_A R_B + R_B R_C + R_C R_A}{R_A}$$

$$R_3 = \frac{R_A R_B + R_B R_C + R_C R_A}{R_B}$$

$$R_1 = \frac{R_A R_B + R_B R_C + R_C R_A}{R_C}$$

(B) In the parallel circuit, voltmeter across 3 Ω resistor reads 45V. What is the indication on the ammeter? Also find input power factor. (10)

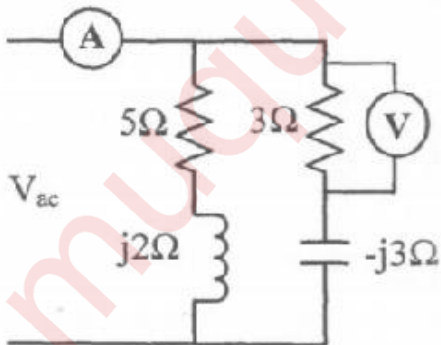

SOLUTION:

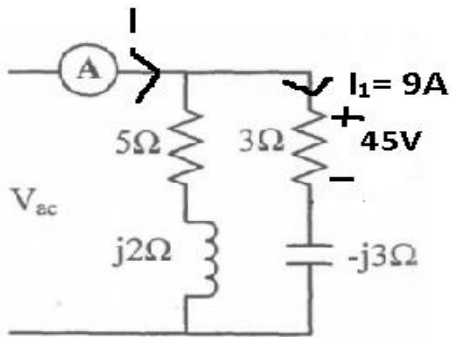

$$I_1 = \frac{45}{5} = 9A$$

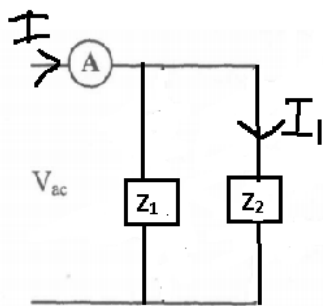

$$Z_1 = 5 + j2 = 5.385 \angle 21.8^\circ, \quad Z_2 = 5 - j3 = 5.83 \angle -30.96^\circ$$

Applying Current Division rule,

$$I_1 = \left(\frac{Z_1}{Z_1 + Z_2} \right) I$$

$$\text{Therefore } I = \frac{Z_1 + Z_2}{Z_1} \times I_1 = \left(\frac{5.385 \angle 21.8^\circ + 5.83 \angle -30.96^\circ}{5.385 \angle 21.8^\circ} \right) \times 9 = 1.866 \angle -27.5^\circ A$$

Ammeter reading is 1.866A

And input power factor is $\cos(-27.5) = 0.887$ lagging

Q6. (A) Find current through 5Ω from A to B using Thevenin's theorem.(10)

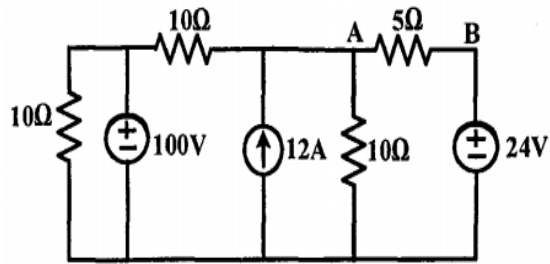

SOLUTION: Using source transformation the equivalent circuit is,

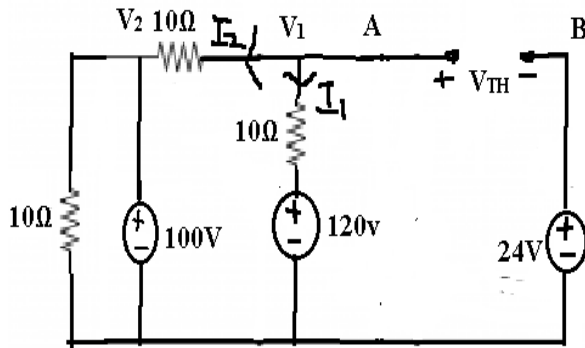

To find V_{TH}

Now using nodal analysis at V_1

$$V_2 = 100\text{v}$$

$$\frac{V_1 - V_2}{10} + \frac{V_1 - 120}{10} = \frac{V_1 - 100}{10} + \frac{V_1 - 120}{10} = 0$$

$$V_1 - 100 + V_1 - 120 = 2V_1 - 220 = 0$$

$$V_1 = 110\text{v}$$

$$V_{TH} = 110 - 24 = 86\text{v}$$

To find R_{TH} ,

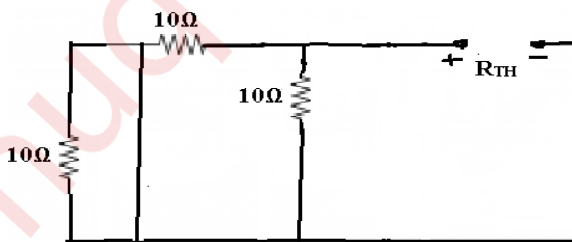

$$R_{TH} = (10//10) = \frac{10 \times 10}{10 + 10} = 5\Omega$$

The Thevenin's equivalent circuit,

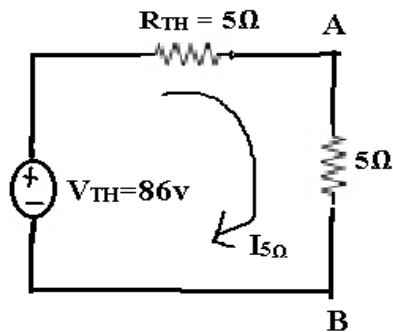

The current through 5Ω Resistor will be,

$$I_{5\Omega} = \frac{86}{5+5} = 8.6\text{A}$$

(B) A 20KVA Transformer has iron loss of 450W and full load copper loss of 900W. Assume power factor of load as 0.8 lagging. Find full load and half load efficiency of the transformer. (5)

SOLUTION: Given $W_i = 450\text{W}$, $W_{cu} = 900\text{W}$

At full load $x = 1$

$$\begin{aligned} \% \eta &= \frac{(x \times \text{full-load KVA} \times \text{pf})}{(x \times \text{full-load KVA} \times \text{pf}) + W_i + x^2 [W_{cu}]} \times 100 \\ &= \frac{(1 \times 20 \times 0.8)}{(1 \times 20 \times 0.8) + 0.45 + 1^2 \times 0.9} \times 100 = 92.21\% \end{aligned}$$

At half load $x = 0.5$,

$$\% \eta = \frac{(0.5 \times 20 \times 0.8)}{(0.5 \times 20 \times 0.8) + 0.45 + 0.5^2 \times 0.9} \times 100 = 83.33\%$$

(C) Briefly explain the principle of operation of three phase induction motor.

What are the types of three phase induction motor? (5)

SOLUTION:

The motor which works on the principle of electromagnetic induction is known as the induction motor. The electromagnetic induction is the phenomenon in which the electromotive force induces across the electrical conductor when it is placed in a rotating magnetic field.

The stator and rotor are two essential parts of the motor. The stator is the stationary part, and it carries the overlapping windings while the rotor carries the main or field winding. The windings of the stator are equally displaced from each other by an angle of 120° .

The induction motor is the single excited motor, i.e., the supply is applied only to the one part, i.e., stator. The term excitation means the process of inducing the magnetic field on the parts of the motor.

When the three phase supply is given to the stator, the rotating magnetic field produced on it. The figure below shows the rotating magnetic field set up in the stator.

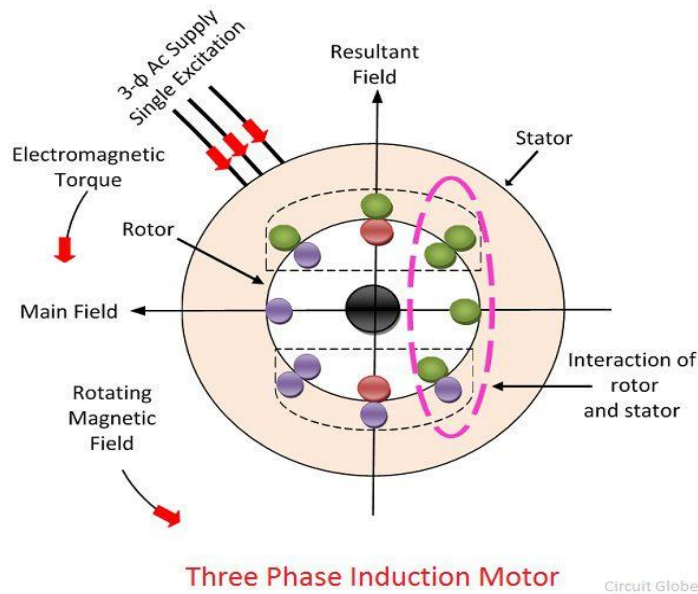

Consider that the rotating magnetic field induces in the anticlockwise direction. The rotating magnetic field has the moving polarities. The polarities of the magnetic field vary by concerning the positive and negative half cycle of the supply. The change in polarities makes the magnetic field rotates.

The conductors of the rotor are stationary. This stationary conductor cut the rotating magnetic field of the stator, and because of the electromagnetic induction, the EMF induces in the rotor. This EMF is known as the rotor induced EMF, and it is because of the electromagnetic induction phenomenon.

The conductors of the rotor are short-circuited either by the end rings or by the help of the external resistance. The relative motion between the rotating magnetic field and the rotor conductor induces the current in the rotor conductors. As the current flows through the conductor, the flux induces on it. The direction of rotor flux is same as that of the rotor current. Now we have two fluxes one because of the rotor and another because of the stator. These fluxes interact each other. On one end of the conductor the fluxes cancel each other, and on the other end, the density of the flux is very high. Thus, the high-density flux tries to push the conductor of rotor towards the low-density flux region. This phenomenon induces the torque on the conductor, and this torque is known as the electromagnetic torque.

The direction of electromagnetic torque and rotating magnetic field is same. Thus, the rotor starts rotating in the same direction as that of the rotating magnetic field.

There are two types of 3 phase Induction motors,

- Squirrel Cage **Induction Motor**.
 - Slip Ring **Induction Motor** or Wound Rotor **Induction Motor** or Phase Wound **Induction Motor**.
-
-