

Q.P. Code :20733

[Time: Three Hours]

[ Marks:80]

Please check whether you have got the right question paper.

- N.B:
1. Question Number 1 is compulsory.
  2. Attempt any 3 questions out of remaining 5 questions.
  3. Assume suitable data wherever necessary and justify.

Q.1 Answer any four

- a) What are the functions of product engineer?
- b) Explain "Major process operation."
- c) Convert the given dimensions into equal bi - lateral tolerances

i)  $25.0^{+0.0}_{-0.4}$

ii)  $40^{+0.03}_{-0.01}$

- d) How are functional important surface on the work piece generally identified?
- e) Explain equilibrium theory.

Q.2 Write short note on,

- a) Centerline theory
- b) Carbide inserts and tool holders.
- c) Critical operation
- d) FMS
- e) ERP

Q.3

- a) The part shown below (material En 1A, Dia 10 mm Bright Bar) in Fig No.1 is to be produced on TRAUB Automat.

- i) Draw the tool layouts
- ii) Prepare the tabulated results
- iii) Calculate output per hour and piece rate
- iv) Draw the set of cams.



Fig. No. 1

- b) "Process engineer should not be a Communicator" – Write true or false with reason.

- Q.4 a) Explain how GT is used in CAPP system? 06  
 b) Prepare the tolerance chart for the given component shown in fig No.2. 14

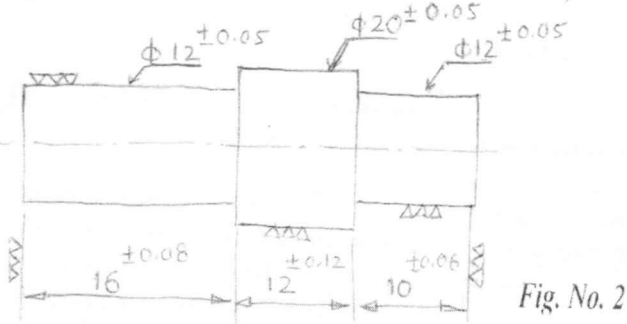

- Q.5 a) Discuss part print analysis for the component Drive Gear (Fig No.3) 15  
 b) Write short note on Modern cutting tool Materials. 05
- Q.6 The component Drive Gear is to be manufactured at an annual rate of 1, 00,000 Qty / year. (Fig No.3) 04
- a) Develop the basic component drawing with appropriate machining allowance and achievable tolerance in basic process you have selected. 12  
 b) In standard format prepare detailed process sheet. The process sheet should indicate operation number, machine, operation description, machining parameters. etc. 04  
 c) Draw the process picture for any one major operation.

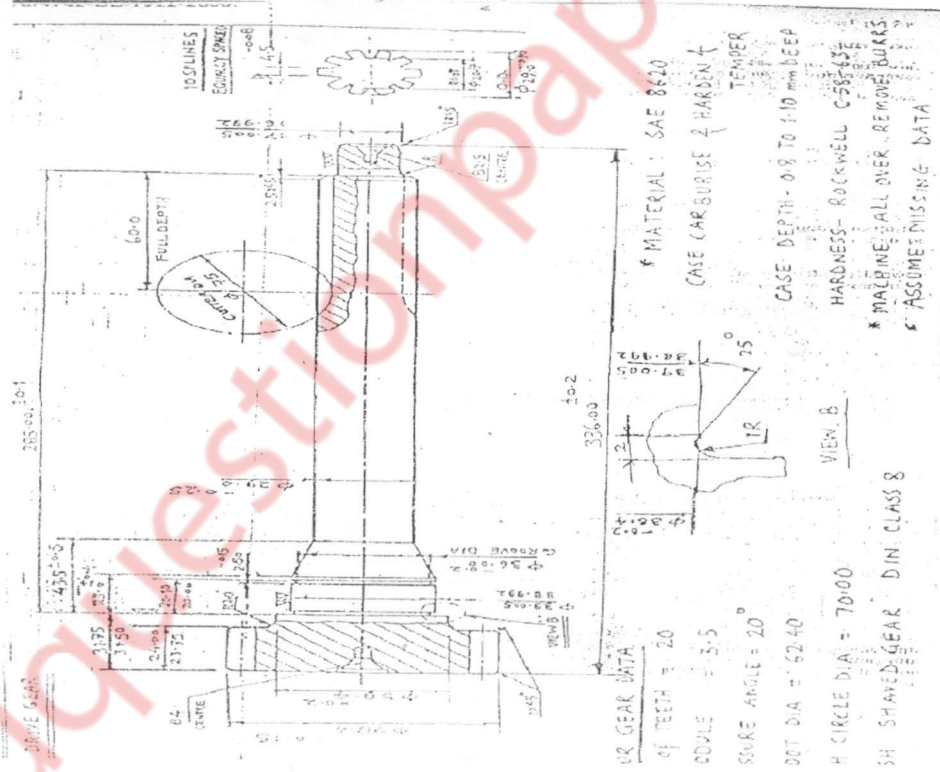

Fig. No. 3

\*\*\*\*\*