

Time: - 3 hr.

Maximum Marks: 80

N.B.: (1) Question No. 1 is compulsory.

(2) Attempt any three questions from the remaining five questions.

(3) Assume suitable data if necessary and mention the same clearly.

(4) Take $g=9.81 \text{ m/s}^2$

Q.1 Attempt any five.

- a. For the force system shown. Find the resultant and locate it with respect to O if the radius of plate is 1m. [4]

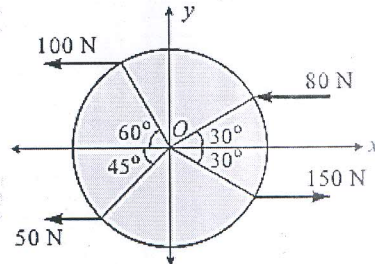

- b. For the system shown in fig. Determine mass m to maintain the equilibrium. [4]

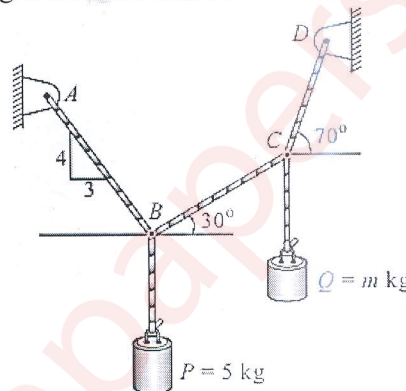

- c. Define laws of friction. [4]
 d. A rectangular plate weighing 500 N is suspended in the horizontal plane using three cables. Find the tension in each cable. [4]

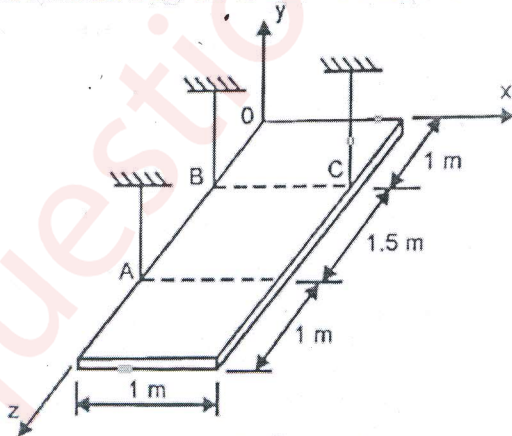

- e. The acceleration of the particle is given by the equation $a = -0.05v^2 \text{ m/s}^2$ [4]
 where, v is the velocity in m/s and x is the displacement in m . Knowing that $v=20 \text{ m/s}$ at $x=0$ determine (i) the position of the particle at $v=15 \text{ m/s}$ (ii) acceleration at $x=50 \text{ m}$.
 f. Define General plane motion and ICR. What are the properties of an ICR. [4]

- Q.2 a. Find the minimum force P required to pull the block. Take the coefficient of friction between A and B as 0.3 and between B and floor as 0.25. [10]

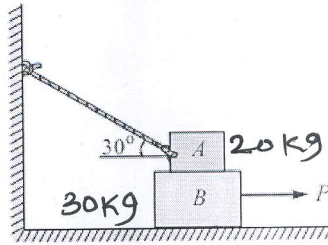

- b. For given system find resultant and its point of application with respect to point A. [6]

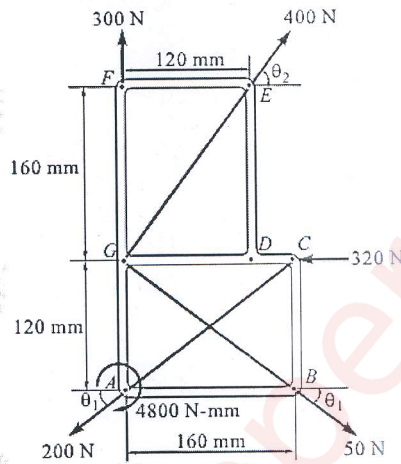

- c. The resultant of the three concurrent space forces at A is $R = -788j$ N. Find magnitude of F_1, F_2, F_3 forces. [4]

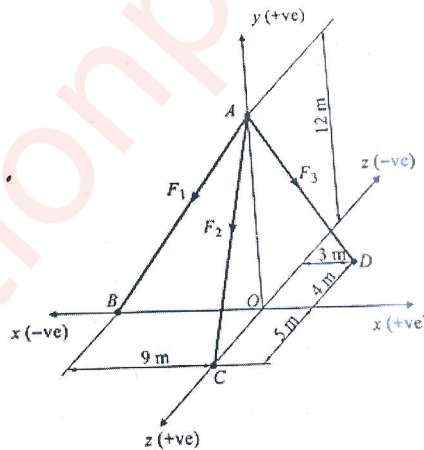

- Q.3 a. Two blocks W_1 and W_2 connected by a horizontal bar AB are supported on rough planes as shown in fig. Considering the coefficient of friction between block A and ground as 0.4 and angle of friction for block B is 20° . Find the smallest weight W_1 for which the equilibrium can exist, if W_2 is 2250 N [8]

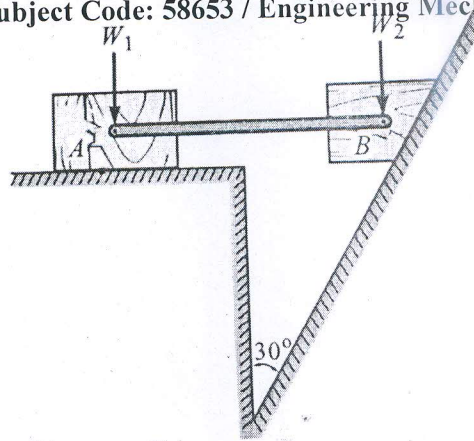

- b. For the system shown in fig. if the collar is moving upwards with a velocity of 1.5m/s. Locate the ICR for the instant shown. Determine angular velocity of rod AB, Velocity of A and velocity at the midpoint of AB. [8]

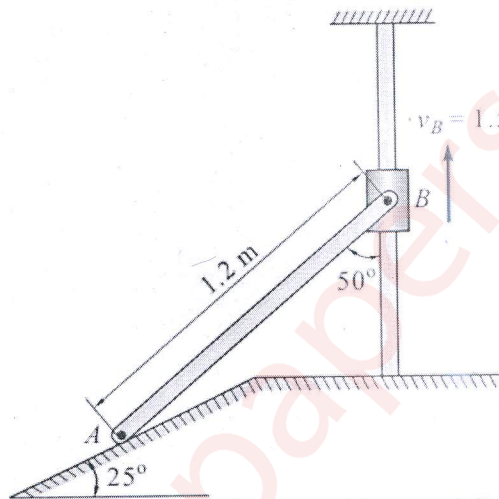

- c. A ball thrown with a speed of 12m/s at an angle of 60° with a building strikes the ground 11.3m horizontally from the foot of the building as shown in fig. Determine the height of the building. [4]

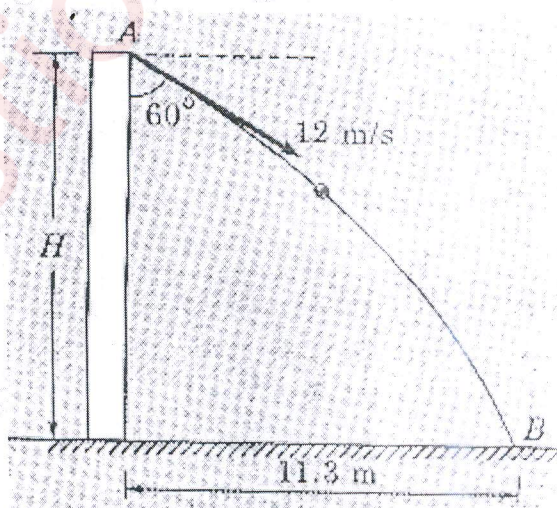

- Q.4 a. A car moves along a straight road such that its acceleration time motion is described by the graph shown in fig. construct v-t and s-t graphs and determine the maximum speed and maximum distance covered. [8]

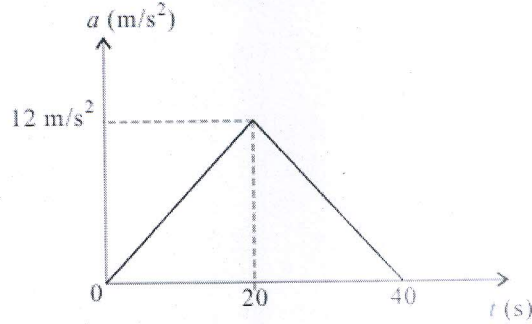

Determine the centroid of the shaded area.

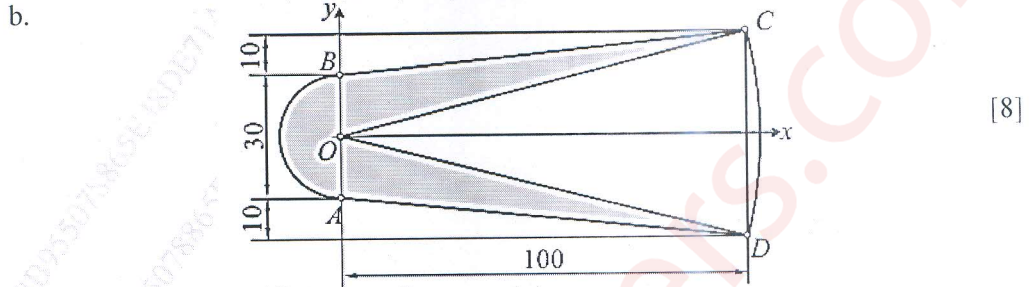

- c. A rectangular parallelepiped carries four forces shown in fig. Reduce the force system to a resultant force applied at the origin. [4]

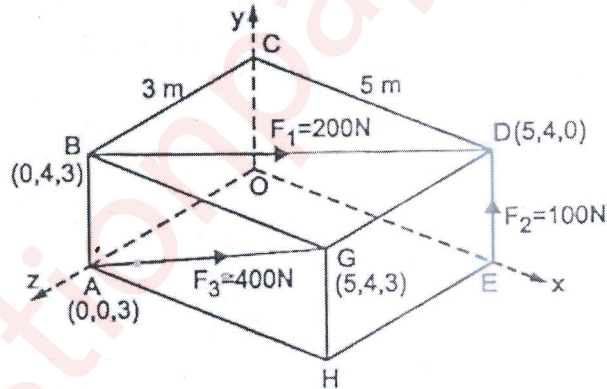

- Q.5 a. Find the centroid of the shaded area. [8]

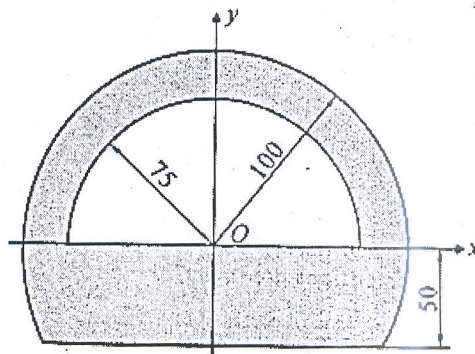

- b. Determine force P applied at 45° to the horizontal just necessary to start a roller of 100 cm diameter and weighing 100 kg over a block of 12 cm high. [6]

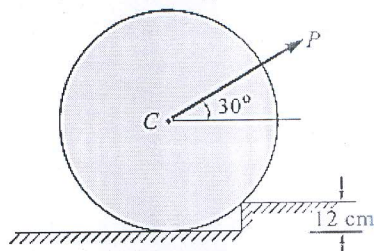

- c. A point moving along a path $y=x^2/3$ with a constant speed of 8m/s. What are the x and y components of its velocity when $x=3$ m? Also, find the radius of curvature and acceleration. [6]

- Q.6 a. Knowing that at the instant the angular velocity of rod BE is 4 rad/sec counterclockwise determine the angular velocity of rod AD and velocity of collar D. [8]

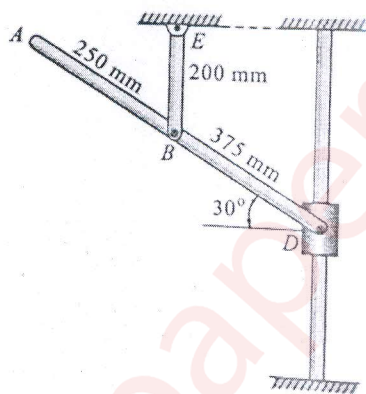

- b. Find the support reactions for the beam loaded as shown in fig. [6]

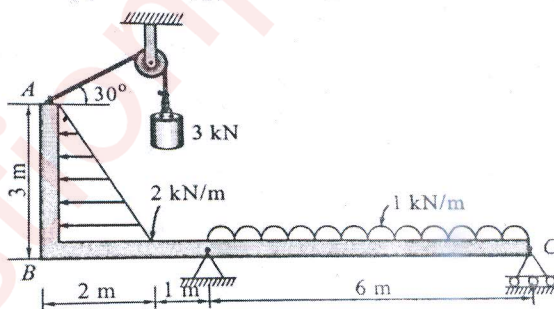

- c. Two identical rollers of mass 50kg are supported as shown in figure. To maintain the equilibrium, Determine the support reactions assuming all smooth surfaces. [6]

