

Time: 3 Hr

Max. Marks:- 80

Note: - 1) Question No1. is compulsory.
2) Attempt any Three out of remaining.

- Q1** Attempt any **FOUR** (20)
- a) Derive an emf equation of a DC Machine (5)
 - b) Calculate the total power and readings of two wattmeters connected to measure power in three phase balanced load if the apparent power is 15KVA & load pf is 0.8 lag. (5)
 - c) In inductive coil containing resistance 20Ω and inductance of $0.2H$ is connected in parallel with a capacitor of $150\mu F$. Find resonant frequency of the circuit, dynamic impedance of the circuit and current in the circuit. (5)
 - d) Find current in 5Ω by nodal analysis. (5)

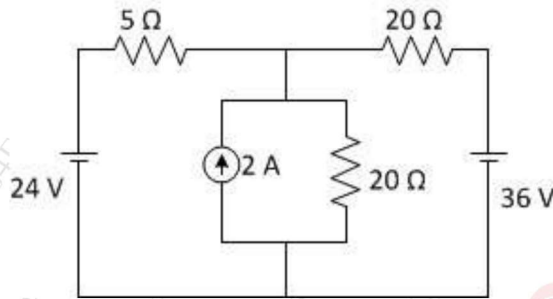

- e) Three currents are meeting at a point. Find the resultant current. (5)
 $i_1 = 50 \sin(\omega t)A$, $i_2 = 25 \cos(\omega t - \frac{\pi}{6})A$,
 $i_3 = -10 \sin(\omega t + \frac{\pi}{4})A$.

- Q2** a) Find current in 1Ω resistance by superposition theorem. (10)

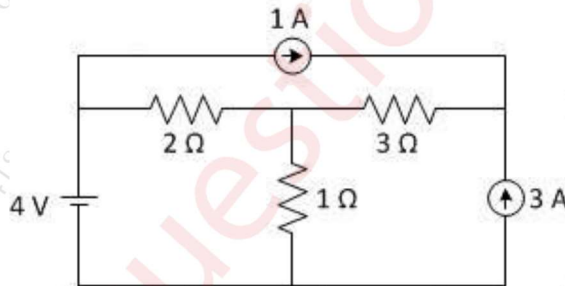

- b) Find maximum power in RL. (10)

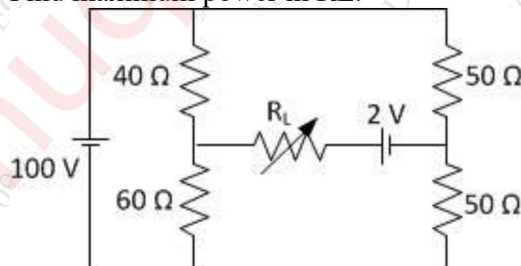

- Q3 a)** Find equivalent resistance between A & B in the network shown. **(10)**

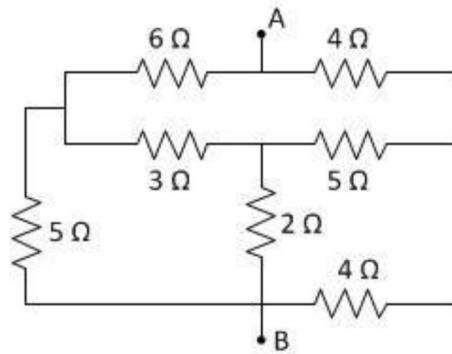

- b)** A 100Ω resistance is connected in series with a choke coil. A voltage of 400V , 50Hz is applied across this combination. The voltage across resistance and coil is 200V and 300V respectively. Find resistance and reactance of a coil, power factor of a coil and complete circuit, power absorbed by resistor, coil and complete circuit. **(10)**
- Q4 a)** A resistor and a capacitor are in series with a variable inductor. When the circuit is connected to a 220V , 50Hz supply, the maximum current obtainable by varying the inductance is 0.314A . The voltage across capacitor is then 80V , find R , L and C . **(10)**
- b)** Explain working principle of three phase induction motor and mention its types. **(5)**
- c)** Explain working of permanent magnet stepper motor. **(5)**
- Q5 a)** Derive relation between line & phase voltage and line & phase current in three phase STAR connected circuit. Also derive equation of active, reactive, and apparent power. **(10)**
- b)** A balanced 3 phase star connected load of 100kW takes a leading current of 80A , when connected across 3 phase 1100V , 50Hz supply. Find the circuit constants of the load per phase, power factor of the load. **(10)**
- Q6 a)** A pure resistor R , a choke coil and a pure capacitor of $15.91\mu\text{F}$ are connected in series across a supply of V volts and carries a current of 0.25A . The voltage across the choke coil is 40V , the voltage across the capacitor is 50V and the voltage across the resistor is 20V . The voltage across the combination of R and the choke coil is 45V . Calculate i) supply voltage ii) frequency iii) the power in choke coil. **(10)**
- b)** An impedance Z_1 is connected in series with two parallel impedances Z_2 and Z_3 . Z_1 consists of a resistance of 6 ohm in series with an inductor of 0.01H . Z_2 consists of a resistance of 4 ohm in series with an inductor of 0.02H . Z_3 consists of a resistance of 2 ohm in series with a capacitor of 200 microfarad . A voltage of 100V at 50Hz frequency is applied across complete circuit. Find impedance of the circuit, current drawn by the circuit, power absorbed by all the three impedances and by complete circuit. **(10)**
