

(3 Hours)

N.B: 1. Question No.1 is compulsory

2. Attempt any three from the remaining five questions

3. Assume suitable data wherever required with proper justification

1. Attempt any four of the following. All sub-questions carry equal marks. 20

(a) An instrument has a natural frequency of 8 Hz. It can withstand a maximum acceleration of  $10 \text{ m/s}^2$ . Determine—angular frequency, displacement amplitude, and maximum velocity.

(b) It is required to design a viscous damper. On what factors does the damping coefficient  $c$  depend? Explain briefly.

(c) State the general form of Lagrange's Equation for free, undamped, multi-degree of freedom vibration system for a generalized coordinate  $x_i$  for  $i^{\text{th}}$  d.o.f.

For the given double pendulum system, write the expressions for total kinetic energy and total potential energy.

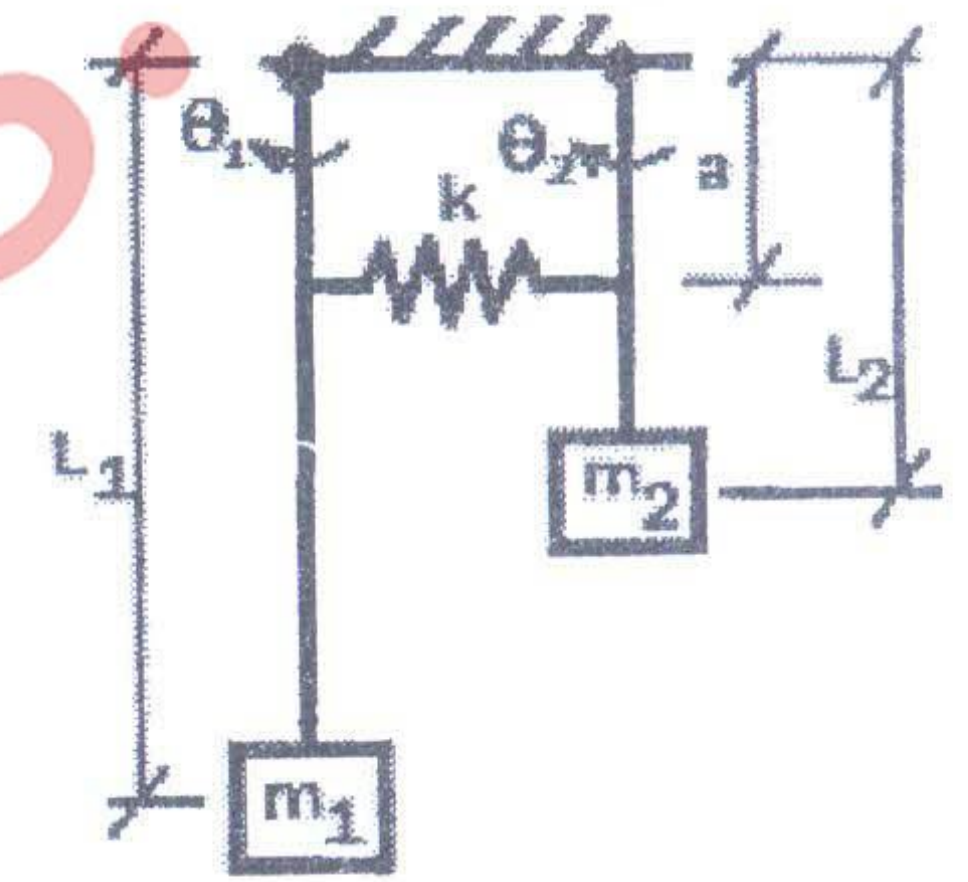

(d) Derive the expression for obtaining peak frequency ratio for the case of frequency-squared excitations. What is the range of values of damping ratio  $\zeta$  for the peak to occur?

(e) An undamped vibration pick-up having a natural frequency of 1 Hz is used to measure a harmonic vibration of 4 Hz. If the amplitude recorded is 0.52 mm, what is the correct amplitude?

(f) Four holes are drilled in a uniform circular disc at a radius of 100 mm and angles of  $0^\circ$ ,  $60^\circ$ ,  $120^\circ$  and  $180^\circ$ . The mass removed at holes 1 and 2 is 100 gm each and the mass removed at holes 3 and 4 is 125 gm each. If the disc is to be balanced statically by drilling a fifth hole at a radius of 125 mm, find the mass to be removed and the angular location of the fifth hole.

2. (a) A water tank column is 100 m high and is made of reinforced concrete with a tubular cross section of inner diameter 2.5 m and outer diameter 3 m. The tank weighs 270 tonnes when filled with water. By neglecting the mass of the column and assuming the Young's modulus of reinforced concrete as  $2.76 \times 10^{10} \text{ N/m}^2$ , determine—(i) the natural time period of transverse vibration of the water tank (ii) the vibration response of the water tank due to an initial transverse displacement of 25 cm, and (iii) the maximum values of the velocity and acceleration experienced by the water tank. 10

(b) A 75 kg machine is mounted on springs of stiffness  $11.76 \times 10^5 \text{ N/m}$  with 0.2 as damping ratio. A 2 kg piston within the machine has reciprocating motion with a stroke of 0.08 m and a speed of 3000 r.p.m. Assuming the motion of the piston to be simple harmonic, determine—(i) the amplitude of motion of the machine, and (ii) its phase angle with respect to the exciting force. 10



3. (a) A body of mass 2 kg lies on a dry horizontal plane and is connected to a rigid support through an inclined spring of stiffness 200 N/m. The spring has its own mass of 600 grams. The mass is displaced from the unstressed position by an amount equal to 0.25 m, and then released with zero velocity. How long will the body vibrate and at what distance from the unstressed position will it stop if the coefficient of friction is 0.25? 10
- (b) An accelerometer is constructed by suspending a mass of 0.1 kg from a spring of stiffness 10,000 N/m with negligible damping. When mounted on the foundation of an engine, the peak-to-peak travel of the mass of the accelerometer has been found to be 10 mm at an engine speed of 1000 rpm. Determine the maximum values of displacement, velocity, and acceleration of the foundation. 10
4. (a) Using  $x$  as the generalized coordinate, determine the following system's equivalent parameters. 8

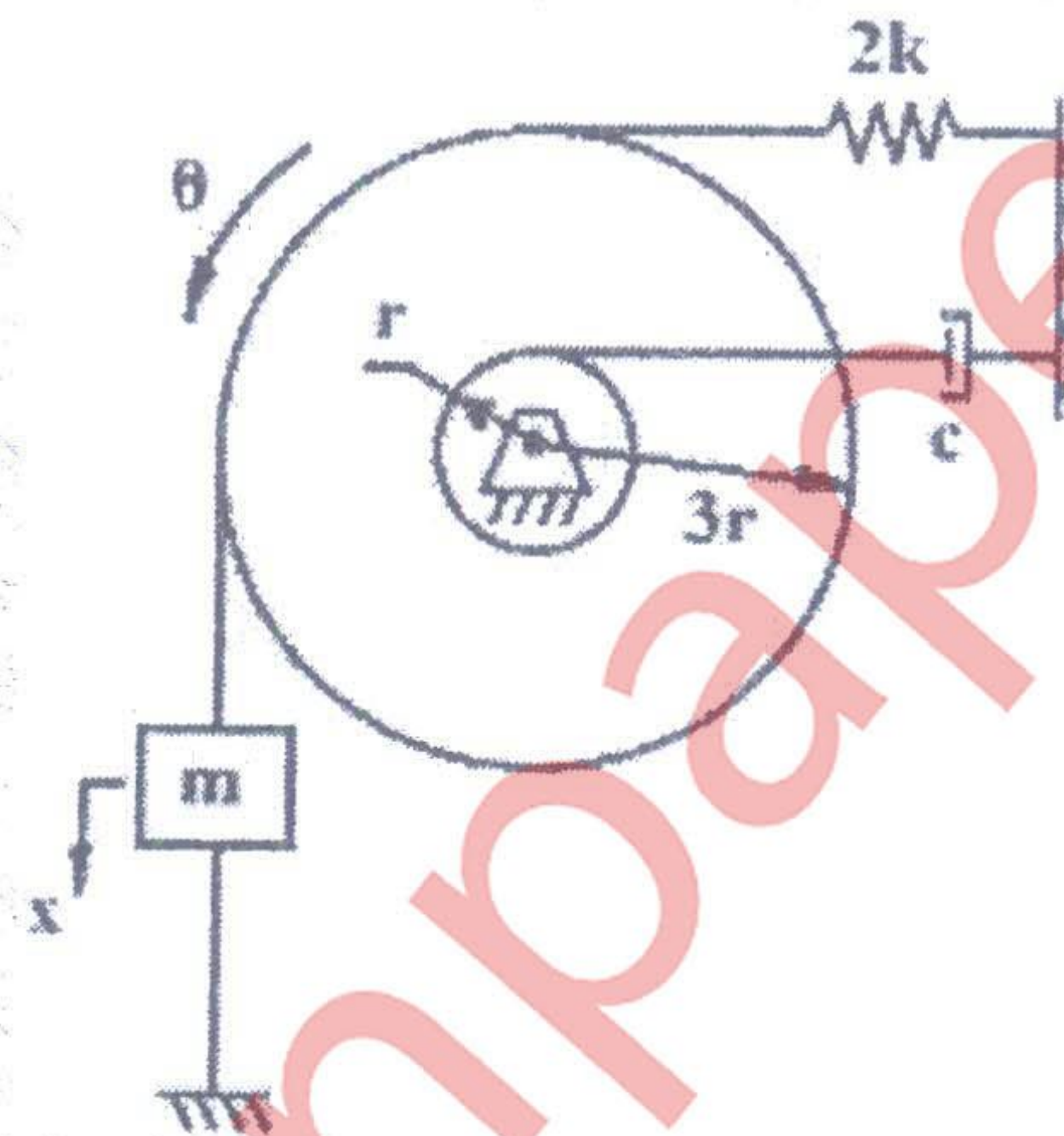

- (b) Four masses A, B, C and D as shown below are to be completely balanced. 8

Masses (kg)	$m_A$	$m_B = 30$	$m_C = 50$	$m_D = 40$
Radius (mm)	180	240	120	150

The planes containing masses B and C are 300 mm apart. The angle between planes containing B and C is  $90^\circ$ . B and C make angles of  $210^\circ$  and  $120^\circ$  respectively with D in the same sense. Find—(i) the magnitude and the angular position of mass A, and (ii) the position of planes A and D.

- (c) Name the methods available for the frequency analysis of the systems with several degrees of freedom. 4
5. (a) The reciprocating mass, crank-radius, and connecting-rod length of each of the cylinders in a two-cylinder in-line engine are given by  $m$ ,  $r$ , and  $l$ , respectively. The crank angles of the two cylinders are separated by  $180^\circ$ . Find the unbalanced forces and couples in the engine. Assume that the reference plane is placed mid-way between the two cylinders. 10
- (b) An engine is mounted on a rigid foundation through four springs. During operation, the engine produces an excitation force at a frequency of 3000 rpm. If the weight of the engine causes the springs to deflect by 10 mm, determine the reduction in the force transmitted to the foundation. 10



6. (a) A circular disc of mass  $m$  and radius  $r$  is suspended freely by four taut massless strings of the same length  $L$ , at radius  $a$  from the polar axis and at equal angular intervals, as shown in the figure below. The disc is disturbed (rotated) slightly about the polar axis. Derive the differential equation of resulting motion using Newton's method, assuming small  $\theta$ . 5

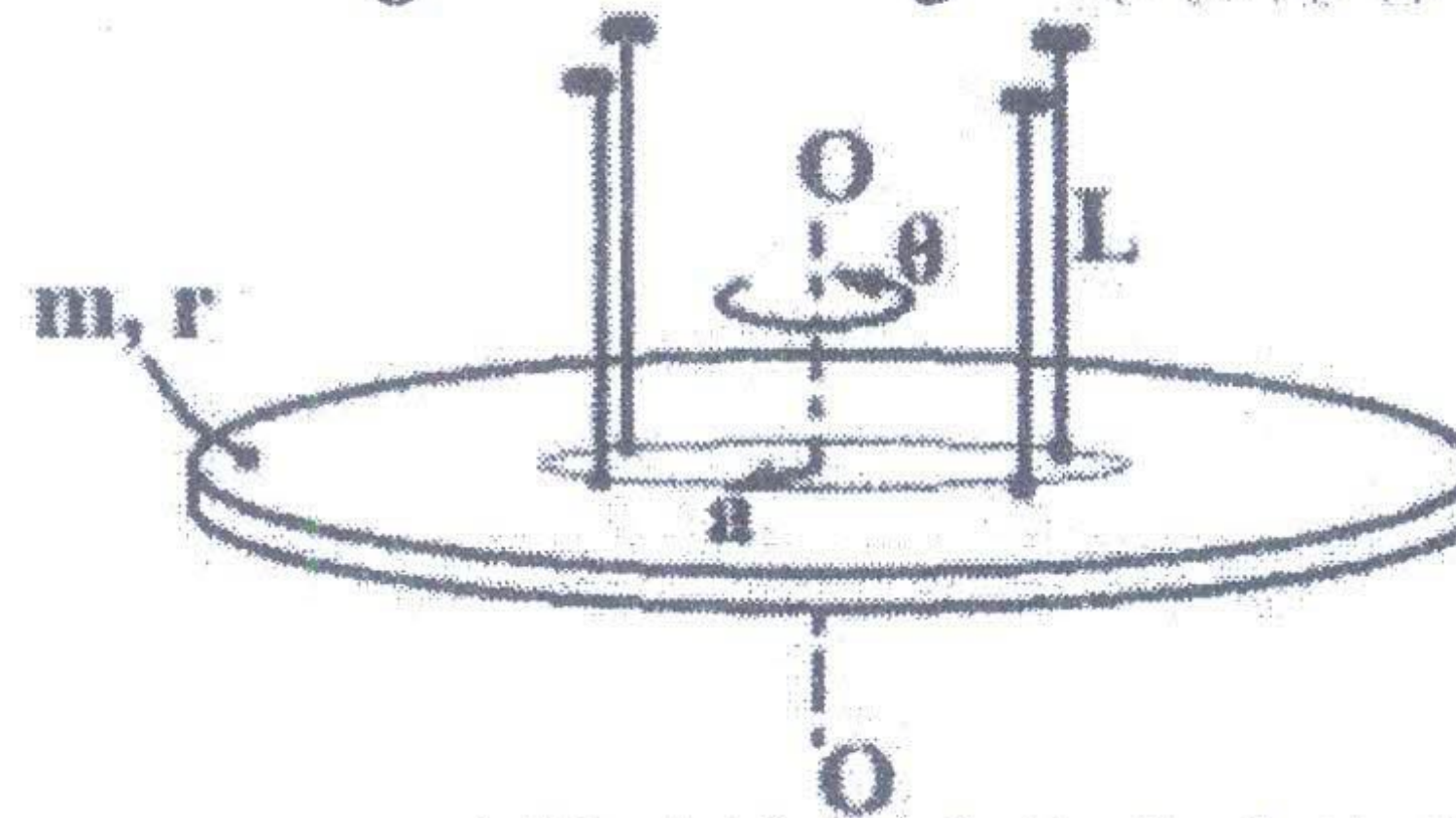

- (b) The natural frequency of transverse vibration of beam in figure below is 20 rad/s. Find the natural frequency of vibration if another 50 N load is added at 40 cm from the left support. 15

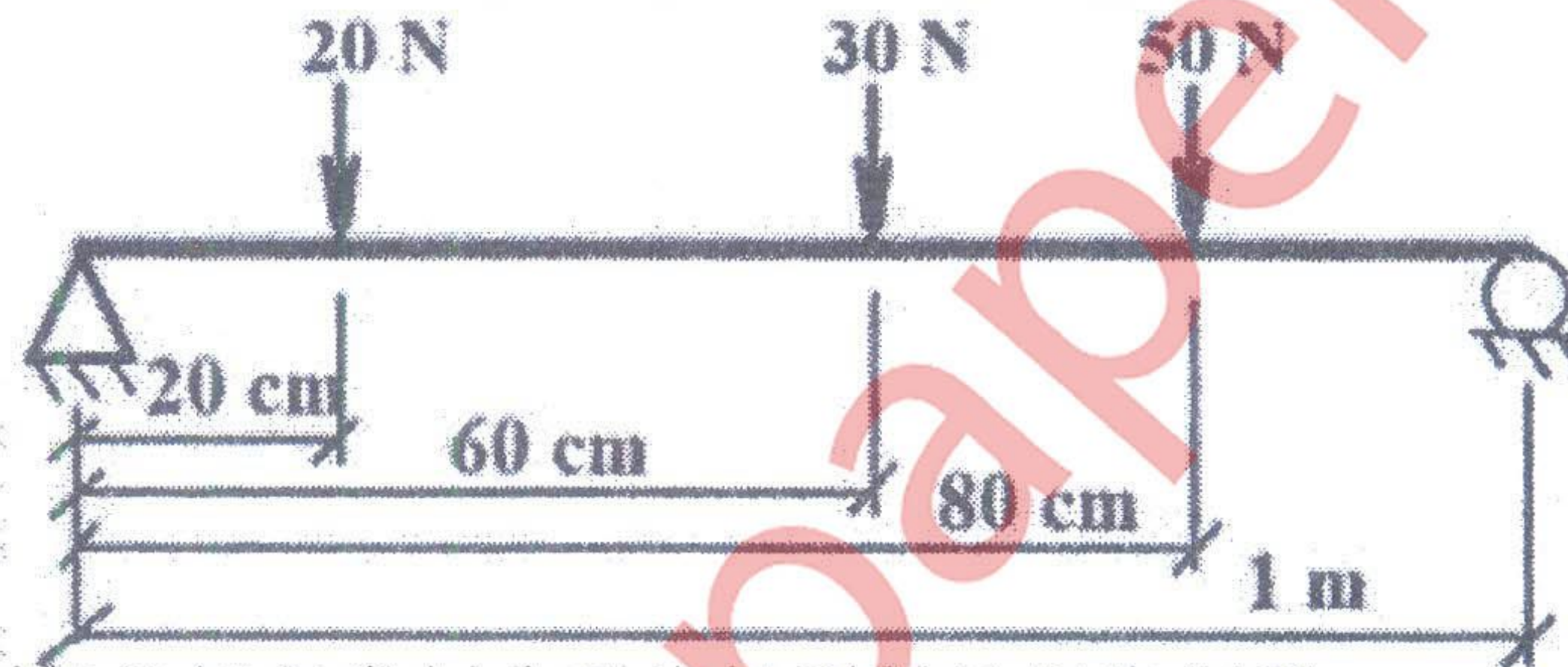

Influence coefficient for simply supported beam can be calculated from the formula—

$$u_{ij} = \frac{S_i Z_j (l^2 - S_i^2 - Z_j^2)}{\text{constant}} = u_{ji}$$

where,  $S_i$  is the distance of node  $i$  from the left support, and  $Z_j$  is the distance of node  $j$  from the right support.