

(03 Hours)

[Total Marks 80]

N.B.:

- (1) Question No.1 is compulsory
- (2) Attempt any three questions out of remaining five questions
- (3) Figures to right indicate full marks
- (4) Assume suitable data if necessary.
- (5) Notations carry usual meaning.

- Q1 a. Write short note on PLC Architecture. 8
 b. With a neat block diagram explain key elements of a mechatronic system with example. 6
 c. What is proportional-integral-differential (PID) controller? Explain role of each of the constituents with neat sketch. 6

- Q2 a. Draw the root-locus of the control system whose open-loop transfer function is given 10
 by

$$G(S)H(S) = \frac{K(S + 2)}{S(S + 5)(S + 8)}$$

Comment on the stability of system.

- b. Reduce the following block diagram to canonical form 6

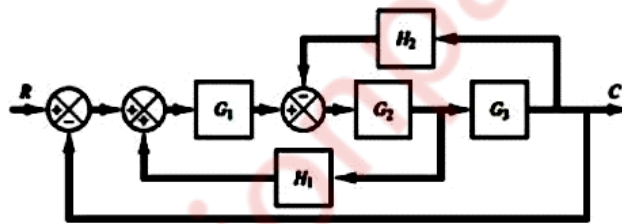

- c. Explain working principle of solenoid actuators. 4

- Q3 a. Two double acting pneumatic cylinders A, B are selected for an industrial application. The sequence of movement for piston of the cylinder is proposed as below— 10

Delay A+ B+ (AB) -

Develop the electro hydraulic circuit using 4/2 double solenoid as final directional control valves. The piston motions mentioned in bracket is simultaneous. Also Draw time - displacement diagram.

- b. Explain the types of temperature sensor, also select the sensor based on the parameters (a) Accuracy (b) Sensitivity. 5
 c. Write note on R-2R circuit. 5

- Q4 a. A process control system illustrated in figure 1 is desired to fill the bottle and convey this. The outlet valve is opened to fill the bottle as when the limit switch senses the presence of bottle and is closed automatically when the photo sensor produces the signal as when the bottle is filled. The level of water in tank is maintained through a control valve. Develop a PLC ladder logic diagram for this control application. **10**

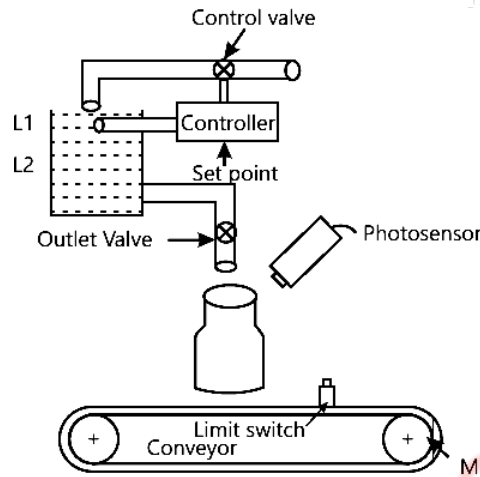

Figure. 1

- b. Explain with neat sketch working principle of DC motor. **5**
- c. With neat diagrams illustrate the working of Filter-Regulator-Lubricator (FRL) unit in a pneumatic system. **5**
- Q5 a. For an open loop transfer function with a unity feedback system **10**

$$G(s) = \frac{4}{S(S+1)}$$

Determine characteristic equation and hence calculate damping ratio, natural frequency, raise time, Peak time, settling time, peak overshoot.

- b. Explain Signal Filters - Low pass, High Pass and Band Pass with circuit diagrams in detail. **10**
- Q6 Write short note on (5 marks each) **20**
- a. Servo Mechanism in Servo motors.
- b. Meter in & Meter out circuit with application.
- c. Mechatronics & its applications in domestic, industrial one example each.
- d. R-2R circuit .