



- N.B. 1) Question No.1 is compulsory.
 2) Attempt any three questions out of the remaining five questions.
 3) Figures to the right indicate full marks.
 4) Assume suitable data wherever required but justify the same.

- Q1. Attempt any four** (20)
- A. Derive an expression for frictional torque for a cone clutch, considering uniform pressure theory.
- B. With the help of neat sketch derive the equation for the ratio of the maximum and minimum tensions in a band and block brake.
- C. What is stability of a governor? Sketch the controlling force versus radius diagrams for a stable, unstable and isochronous spring controlled governor.
- D. What will be the effect of the gyroscopic couple on a disc fixed at a certain angle to a rotating shaft?
- E. What are the conditions to be satisfied for a system to be dynamically equivalent?
- Q2. A.** A friction clutch is used to rotate a machine from a shaft rotating at a uniform speed of 250 rpm. The disc type clutch has both of its sides effective, the coefficient of friction being 0.3. The outer and inner diameters of friction plate are 200 mm and 120 mm respectively. Assuming uniform wear of clutch, the intensity of pressure is not to be more than 100 kN/m^2 . If the moment of inertia of the rotating parts of the machine is 6.5 kg/m^2 , determine the time to attain the full speed by the machine and the energy lost in slipping of the clutch. (10)
- B.** A Proell governor has rotating masses 3 kg each and mass of the sleeve is 20 kg. Each arm is 200 mm long and pivoted at a distance of 20 mm from the axis of rotation. When the governor sleeve is at mid position, the extension link of the lower arm is vertical and the radius of rotation of the balls is 180 mm. At the mid position if the governor speed is 200 rpm, find i) length of the extended link and ii) tension in the upper arm. (10)
- Q3. A.** Derive the equation for the total vertical reaction at each of the outer and inner wheels of a 4 – wheeler considering centrifugal and gyroscopic couple. (10)
- B.** The crank pin circle radius of a horizontal engine is 300 mm. The mass of the reciprocating parts is 250 kg. When the crank has travelled 60° from I.D.C., the difference between the driving and the back pressures is 0.35 N/mm^2 . The connecting rod length between centers is 1.2 m and the cylinder bore is 0.5 m. If the engine runs at 250 rpm and if the effect of piston rod diameter is neglected, calculate; i) pressure on slide bars, ii) thrust in the connecting rod, iii) tangential force on the crank pin and iv) turning moment on the crank shaft. (10)

{Turn Over}

- Q4. A** A simple band brake as shown in **Figure 1** operates on a drum of 600 mm in diameter that is running at 200 rpm. The coefficient of friction is 0.25. The brake band has a contact of 270° , one end is fastened to a fixed pin and the other end to the brake arm 125 mm from the fixed pin. The straight brake arm is 750 mm long and placed perpendicular to the diameter that bisects the angle contact. (10)

- 1) What is the pull necessary on the end of the brake arm to stop the wheel if 35 kW is being absorbed? What is the direction for this minimum pull?
- 2) What width of steel band of 2.5 mm thick is required for this brake if the maximum tensile stress is not to exceed 50 N/mm^2 ?

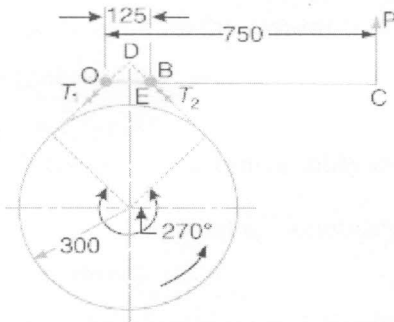

Figure 1

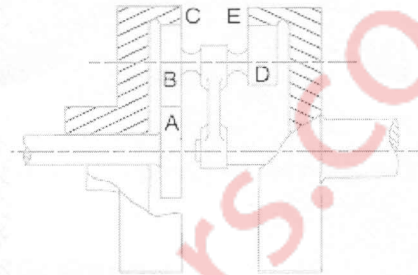

Figure 2

- B.** In the epicyclic gear train as shown in **Figure 2**, the driving gear A rotating in clockwise direction has 14 teeth and the fixed annular gear C has 100 teeth. The ratio of teeth in gears E and D is 98:41. If 1.85 kW is supplied to the gear A rotating at 1200 rpm, find: 1) the speed and direction of rotation of gear E and 2) the fixing torque required at C, assuming 100% efficiency throughout and that all teeth have the same pitch. (10)
- Q5. A.** A punching machine makes 25 working strokes per minute and is capable of punching 25 mm diameter holes in 18 mm thick steel plates having ultimate shear strength 300 MPa. The punching operation takes place during $1/10^{\text{th}}$ of a revolution of the crankshaft. Estimate the power needed for the driving motor, assuming a mechanical efficiency of 95%. Determine suitable dimensions for the rim cross section of the flywheel, having width equal to twice thickness. The flywheel is to revolve at 9 times the speed of the crankshaft. The permissible coefficient of fluctuation of speed is 0.1. The flywheel is to be made of cast iron having a working tensile stress of 6 MPa and density of 7250 kg/m^3 . The diameter of the flywheel must not exceed 1.4 m owing to space restrictions. The hub and the spokes may be assumed to provide 5% of the rotational inertia of the wheel. (10)
- B.** A ship is propelled by a turbine having a mass of 6000 kg and a speed of 2400 rpm. The direction of rotation of the rotor is anticlockwise when viewed from the bow end. The radius of gyration of rotor is 450 mm. Determine gyroscopic effect when, (10)
- i) Ship is steering to the left in a curve of 60 m radius at a speed of 1860 m/hr.
 - ii) Ship is pitching in SHM with bow descending with maximum velocity. The time period of pitching is 18 seconds and the ship pitches 7.5° above and 7.5° below the normal position.
 - iii) Ship is rolling and at the instant, its angular velocity is 0.035 rad/sec counterclockwise when viewed from stern.
 - iv) Also find the maximum angular acceleration during pitching.
- Q6.** Write short notes on:- (20)
- | | |
|--|------------------------------------|
| A. Constant Mesh Gear Box. | B. Hartung governor. |
| C. Belt transmission dynamometer. | D. Requirement of clutches. |