

(3 Hours)

[Total Marks : 80

- N.B. :
- (1) Question No. 1 is compulsory.
 - (2) Attempt any three questions from remaining.
 - (3) Use graph paper and semi log paper wherever required.
 - (4) Assume suitable data wherever necessary and mention the same.
 - (5) Figures to the right indicate full marks.

Q.NO.1) ATTEMPT ANY FIVE

20

A) Draw and explain step responses of standard second order undamped, underdamped, critically damped and overdamped system. Also show pole locations of these systems.

B) Explain effects of addition of open loop poles and zeros on the root locus and transient response.

C) Consider the open loop system having $G(s)H(s) = \frac{K(s+5)}{s(s+3)}$ Check whether

$s = -6.36 + j 2.86$ point is lying on root locus or not. If yes then find value of K at that point.

D) Define Gain Margin, Phase margin, Phase crossover frequency and Gain crossover frequency in frequency domain. Also explain stability via bode plot.

E) What are the advantages of using state space analysis over classical approaches (Transfer Function approach)?

F) Explain AC Servomotor with neat diagram.

Q.NO.2)

10

A) Reduce the block diagram to a single transfer function $T(s) = C(s) / R(s)$ using block diagram reduction technique.

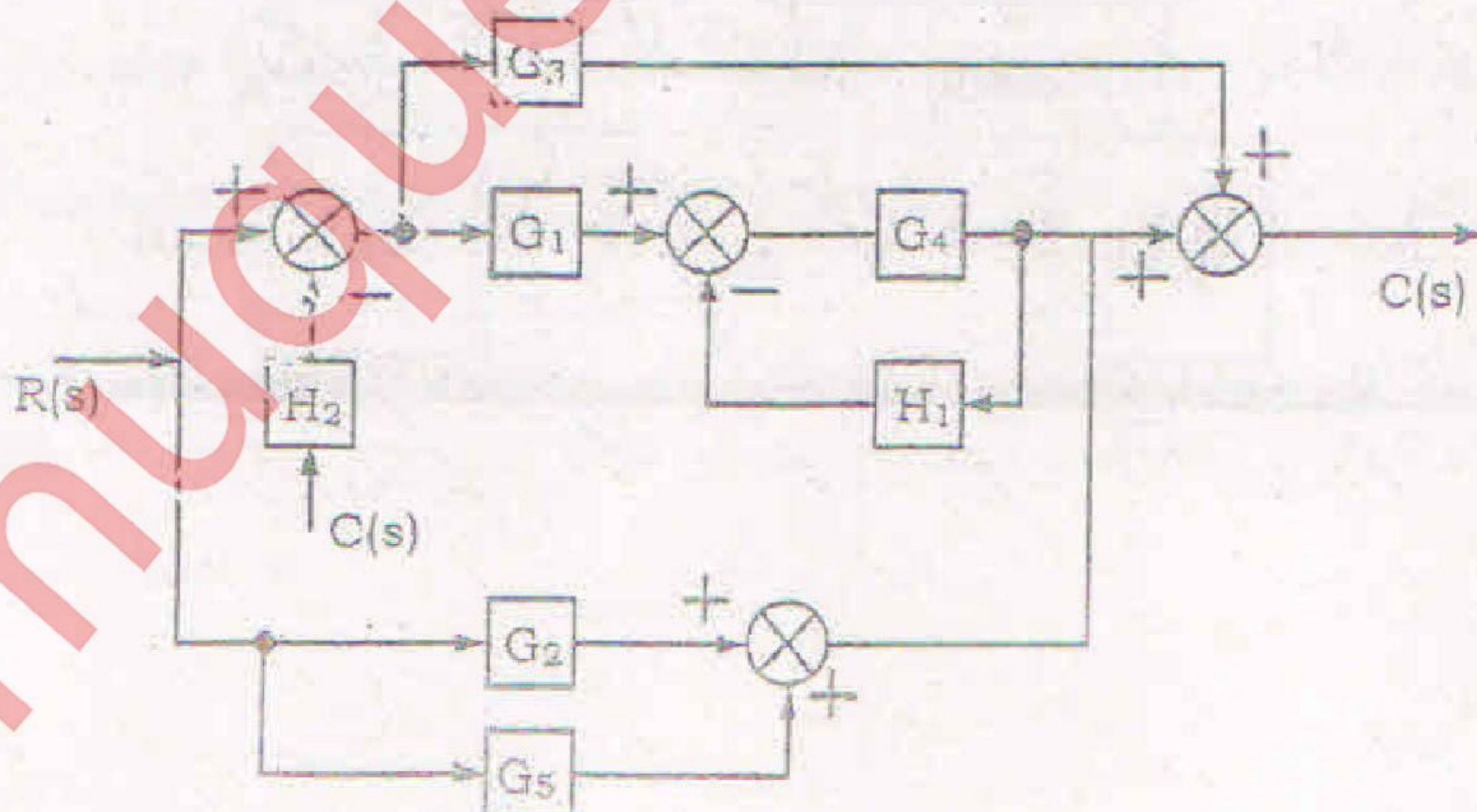

B) Use Masson's gain formula to find $C(s) / R(s)$ of following Signal Flow graph

10

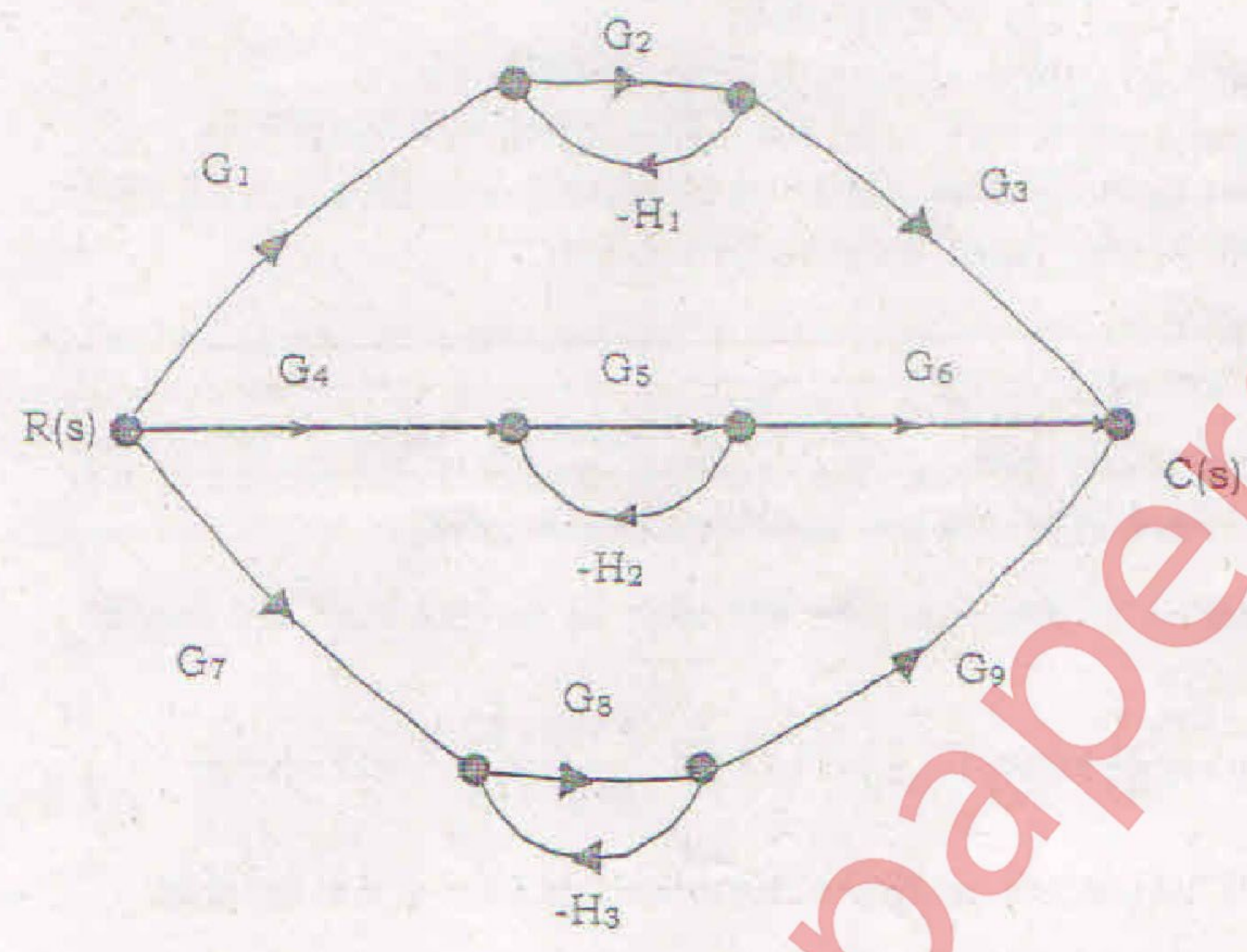

Q.NO.3)

10

A) Find the transfer function $X_1(s) / F(s)$ for the translational mechanical system shown below

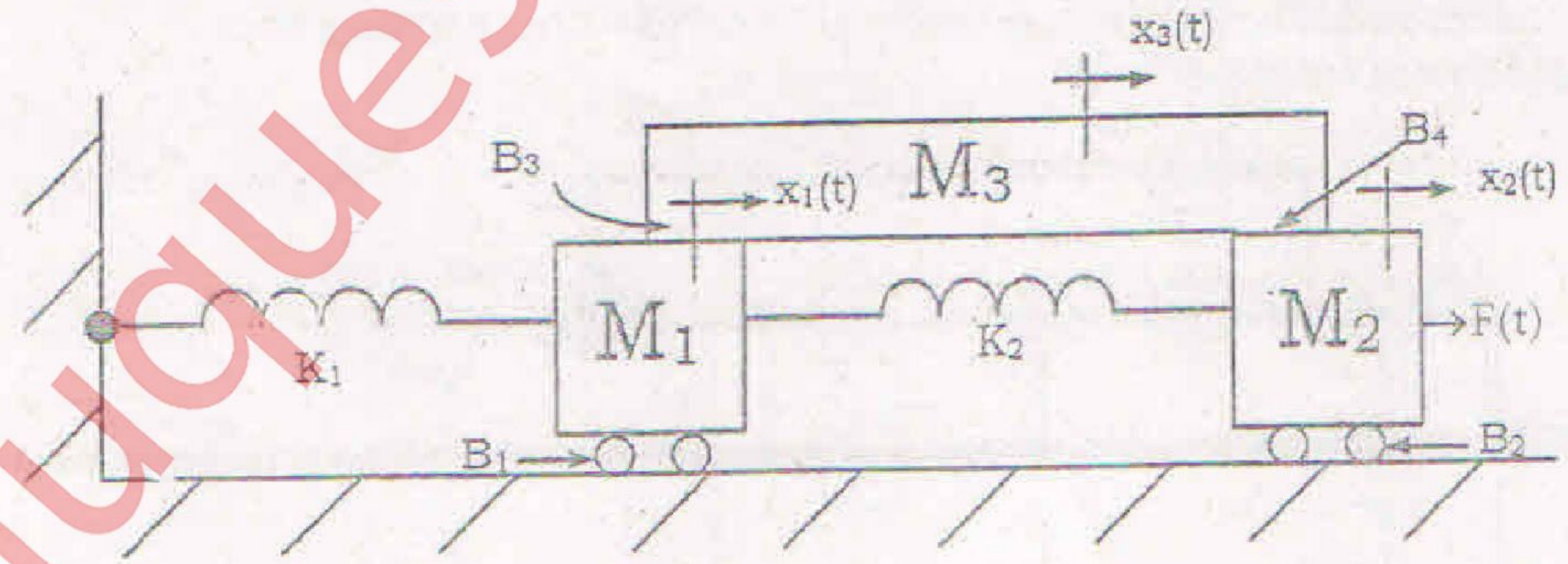

[TURN OVER

3

B) For the pole plot shown in figure, find Damping ratio & natural frequency of oscillations, Peak time, Settling time (for $\pm 2\%$ Tolerance band) and Percentage Overshoot. 10

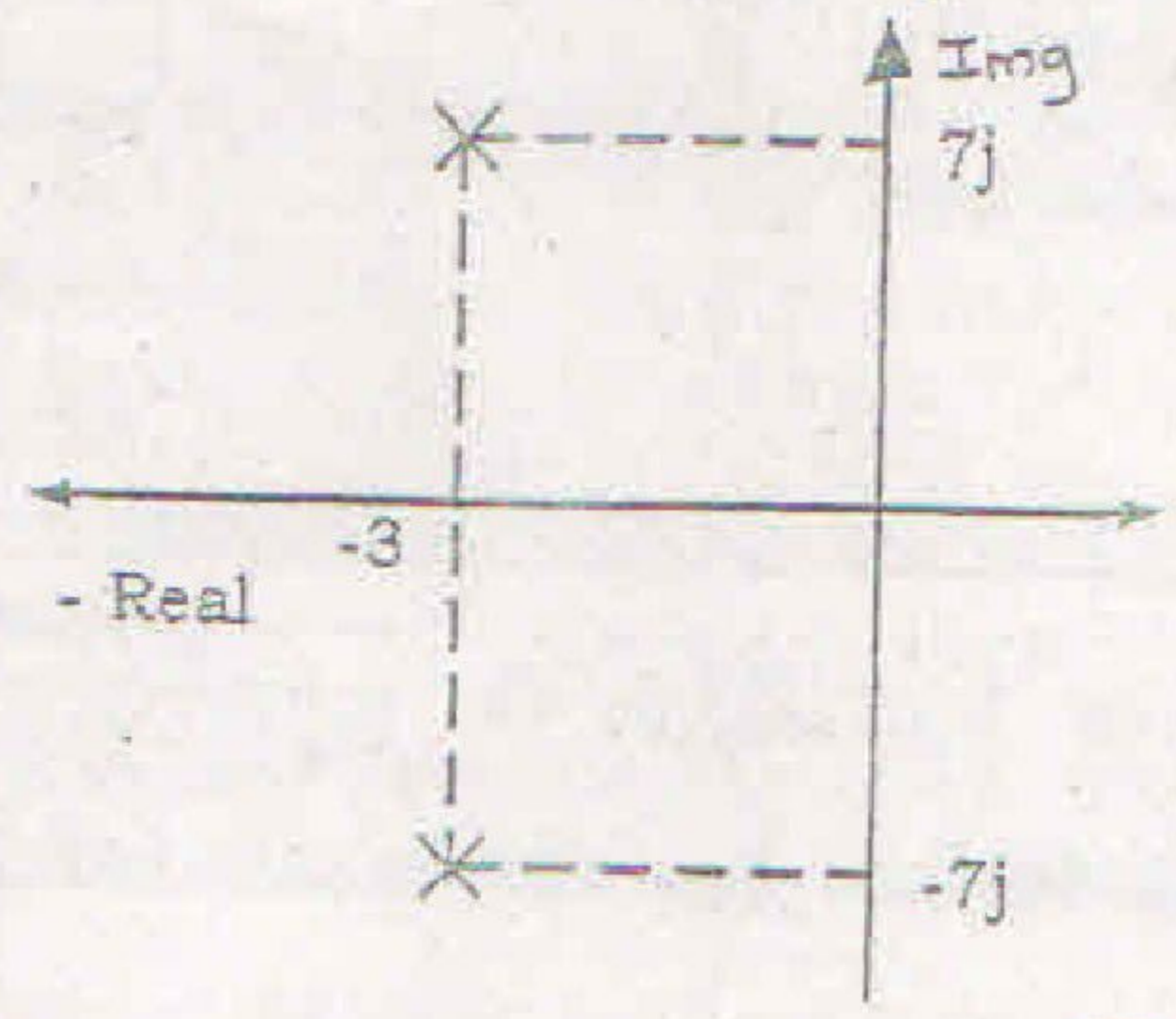

Q.NO. 4)

A) Consider a unity feedback system with Close loop transfer function 10

$\frac{C(s)}{R(s)} = \frac{2}{s^2 + 3s + 7}$ Find Open loop transfer function. Show that the steady state error in the unit step input response is 0.714

B) Determine the range of operating values of 'K' for the unity feedback system having 10

characteristic equation as $K[s^3 + 4s^2 + \frac{1}{K}s + 3] = 0$ by Routh's Hurwitz method. Also explain the importance of auxiliary equation.

Q.NO. 5)

A) For the unity feedback system having

$G(s) = \frac{K(s-3)}{s(s+2)(s+4)(s+8)(s+10)}$ Sketch the root locus. Also find the value of 'K' for damping ratio of 0.5 10

B) For the unity feedback system having

$G(s) = \frac{30(s+1)}{(s+5)(s+50)}$ Sketch Bode plot and find GM, PM, Wgc and Wpc. Also comment on stability. 10

Q.NO. 6)

A) Obtain state space representation in phase variable form of the following transfer function

$$\frac{C(s)}{R(s)} = \frac{10.4s^2 + 47s + 160}{s^3 + 14s^2 + 56s + 160}$$

Also draw state space model.

10

B) Use Nyquist criterion to determine whether the closed loop system having following Open

loop transfer function is stable or not. $G(s)H(s) = \frac{(1+4s)}{s^2(1+s)(1+2s)}$ If not then

how many closed loop poles lie in the RHS of s-plane. Assume unity feedback.

10