

(3 Hours)

(Total Marks: 80)

N. B. 1 Question No. 1 is compulsory

2 Attempt any three questions from remaining questions.

3 Assume any suitable data wherever required but justify the same

Q. No. 1 (a) for the structures shown in Figures, calculate -----

(6F)

1) Static indeterminacy,

2) Kinematic indeterminacy (neglecting axial deformations for flexural members)

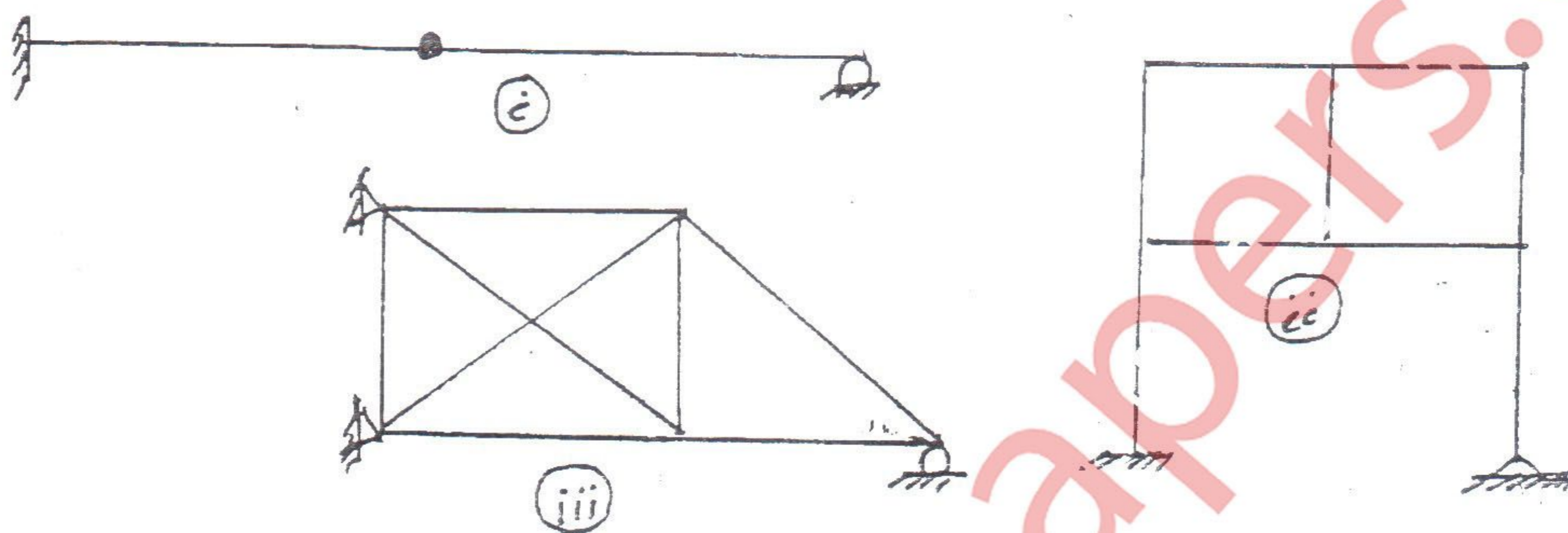

Q. No. 1 (b) Determine the horizontal displacement of joint D of the rigid jointed plane frame as shown in figure, due to change of temperature of member surfaces. Consider depth of all the members as 500mm. Take $\alpha_t = 12 \times 10^{-6} / ^\circ C$

(10)

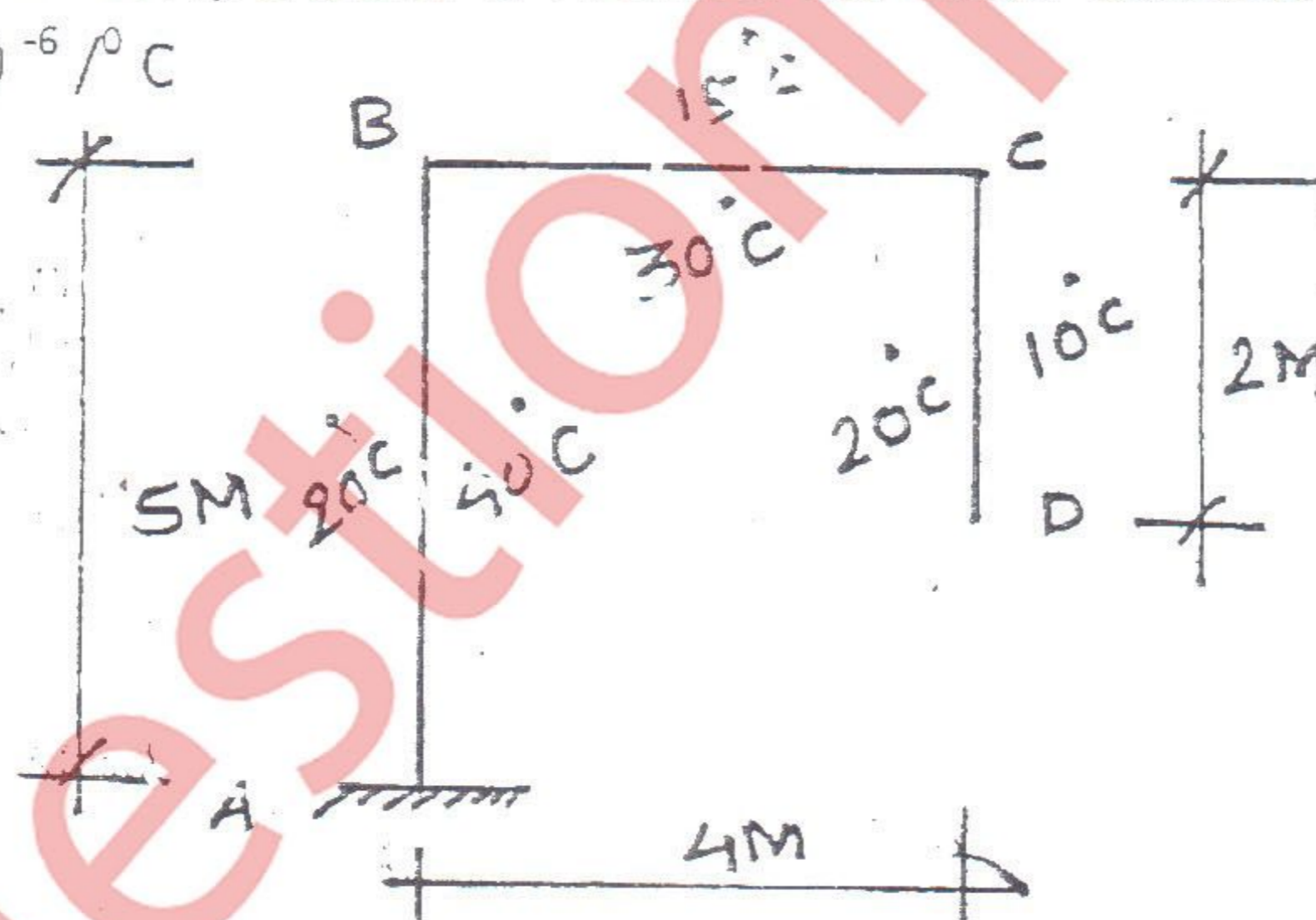

Q. No. 1 (c) Determine the shape factor for the triangular section as shown in figure

(04)

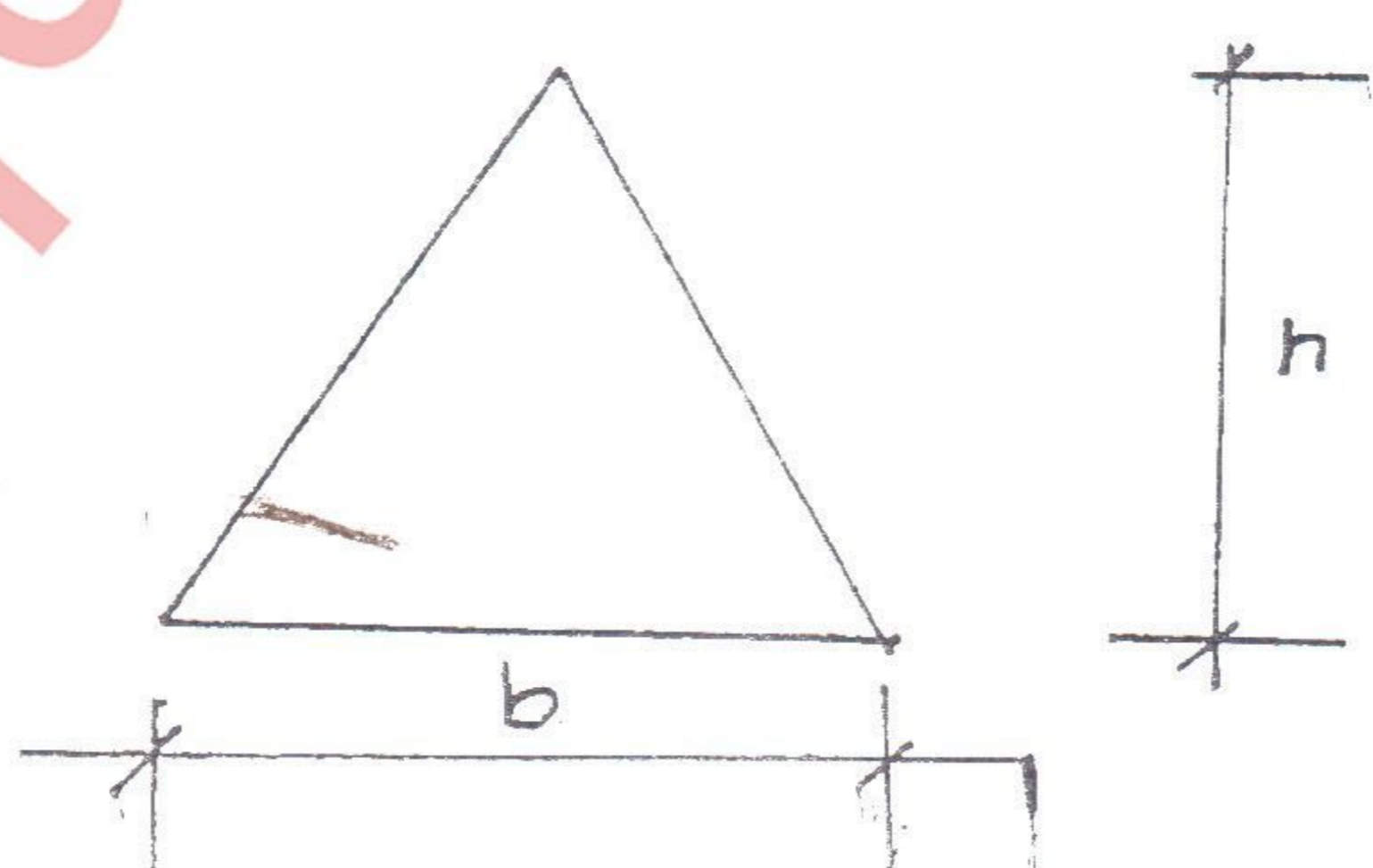

Q. No. 2 a) Analysis the rigid jointed plane frame as shown in figure, using moment distribution Method. Draw BMD, SFD and elastic curve. (10)

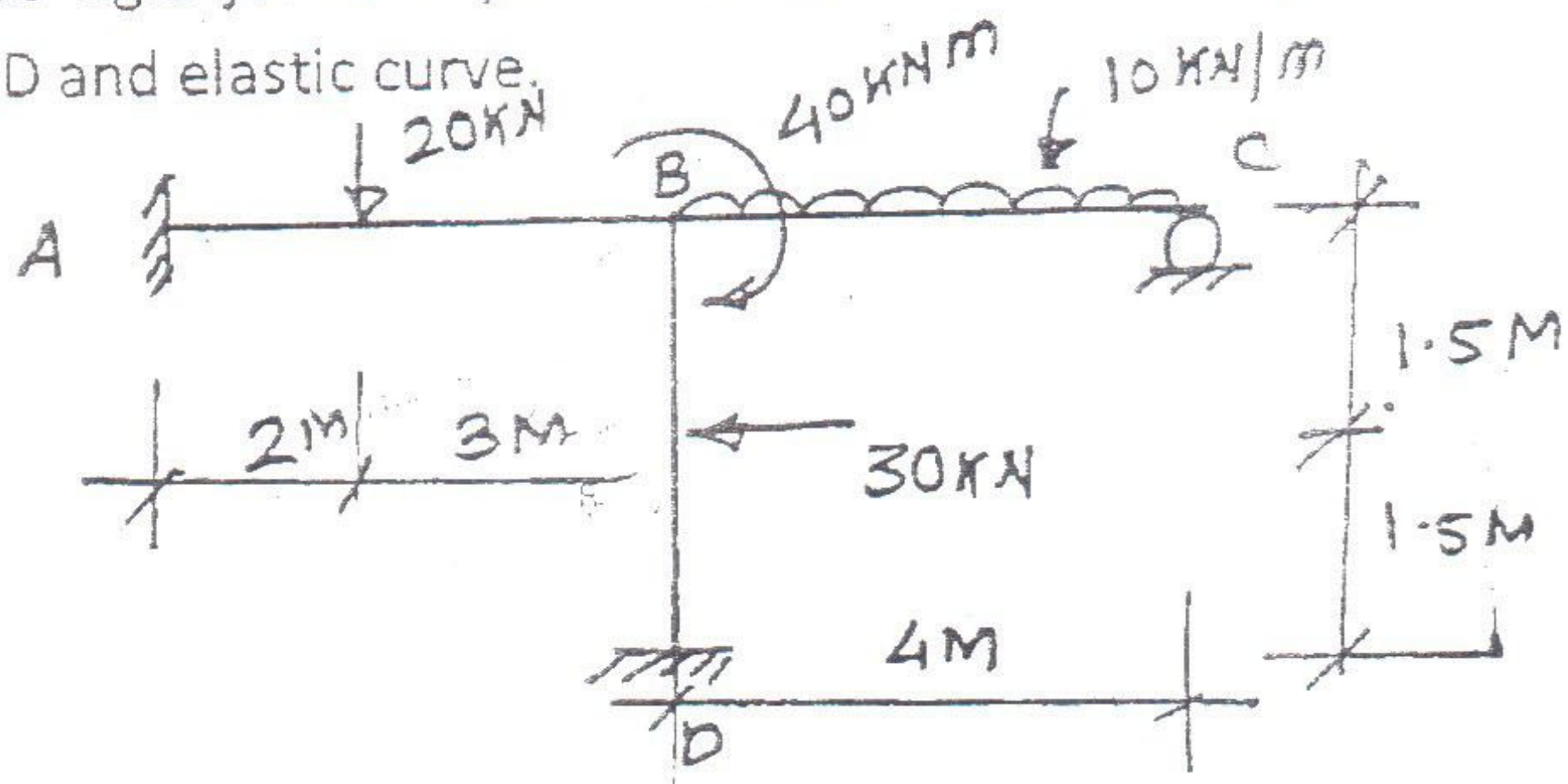

b) Analyse the beam by three moment theorem and draw BMD (10)

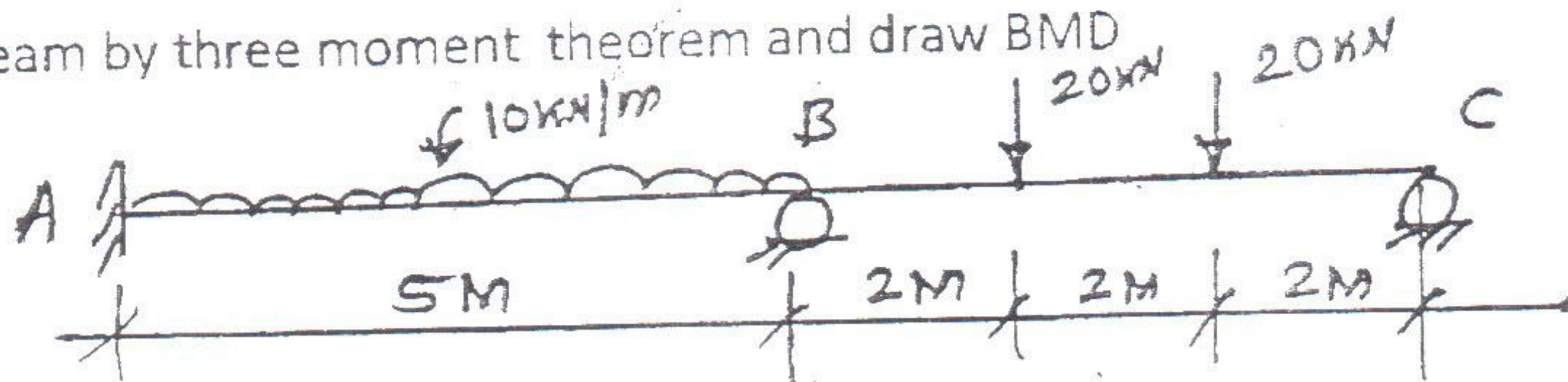

Q. No. 3 Analysis the rigid jointed plane frame as shown in figure, using slope deflection method. Draw BMD, SFD and deflected shape. (12)

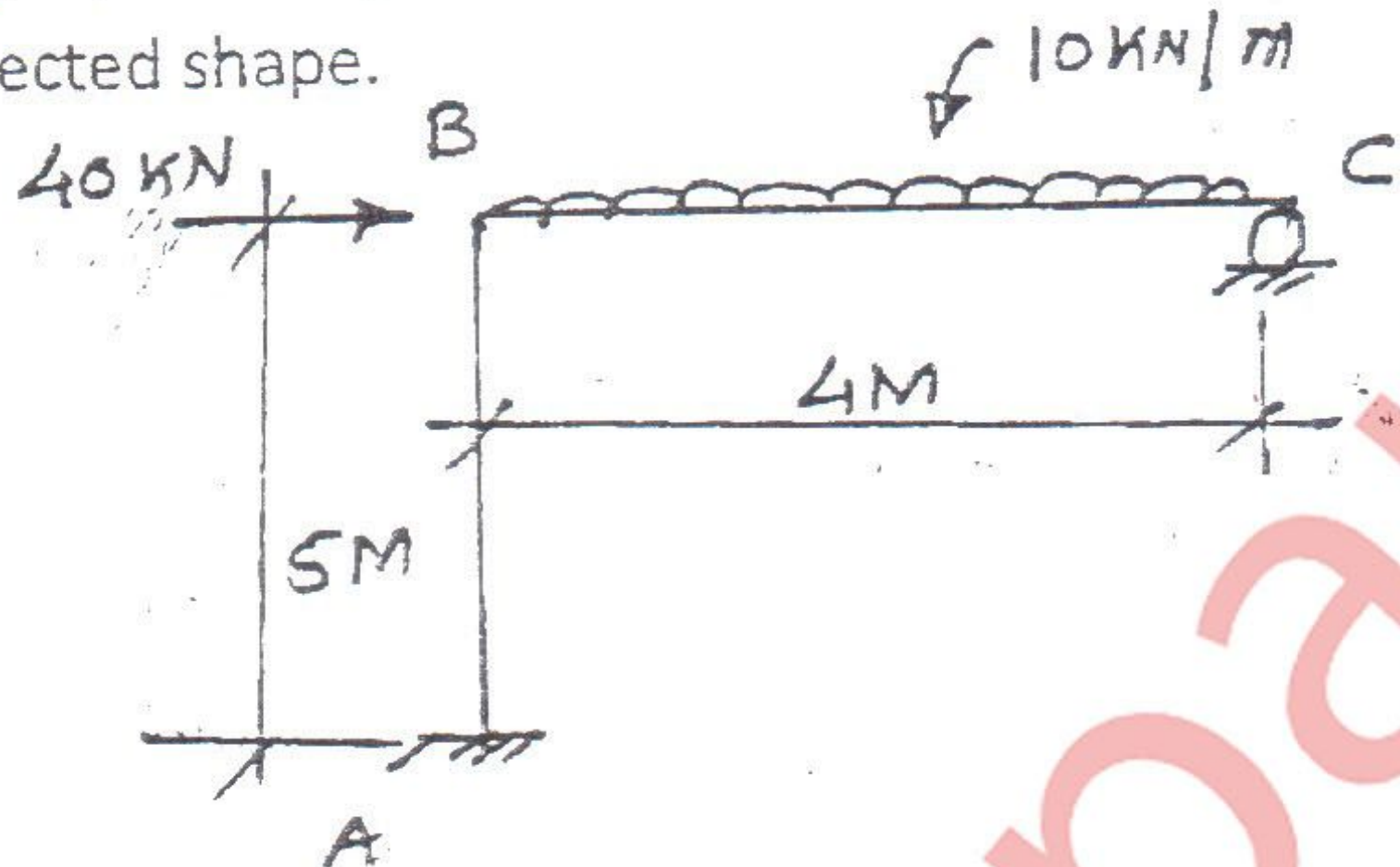

b) A two hinged parabolic arch of span 20 meter and rise 4 meter carries uniformly distributed load of 40 kN/m on right half span find the reaction at the supports and draw BMD (08)

Q. No. 4 Analysis the rigid jointed plane frame as shown in figure, using Flexibility Method. Draw BMD, SFD and deflected shape. (12)

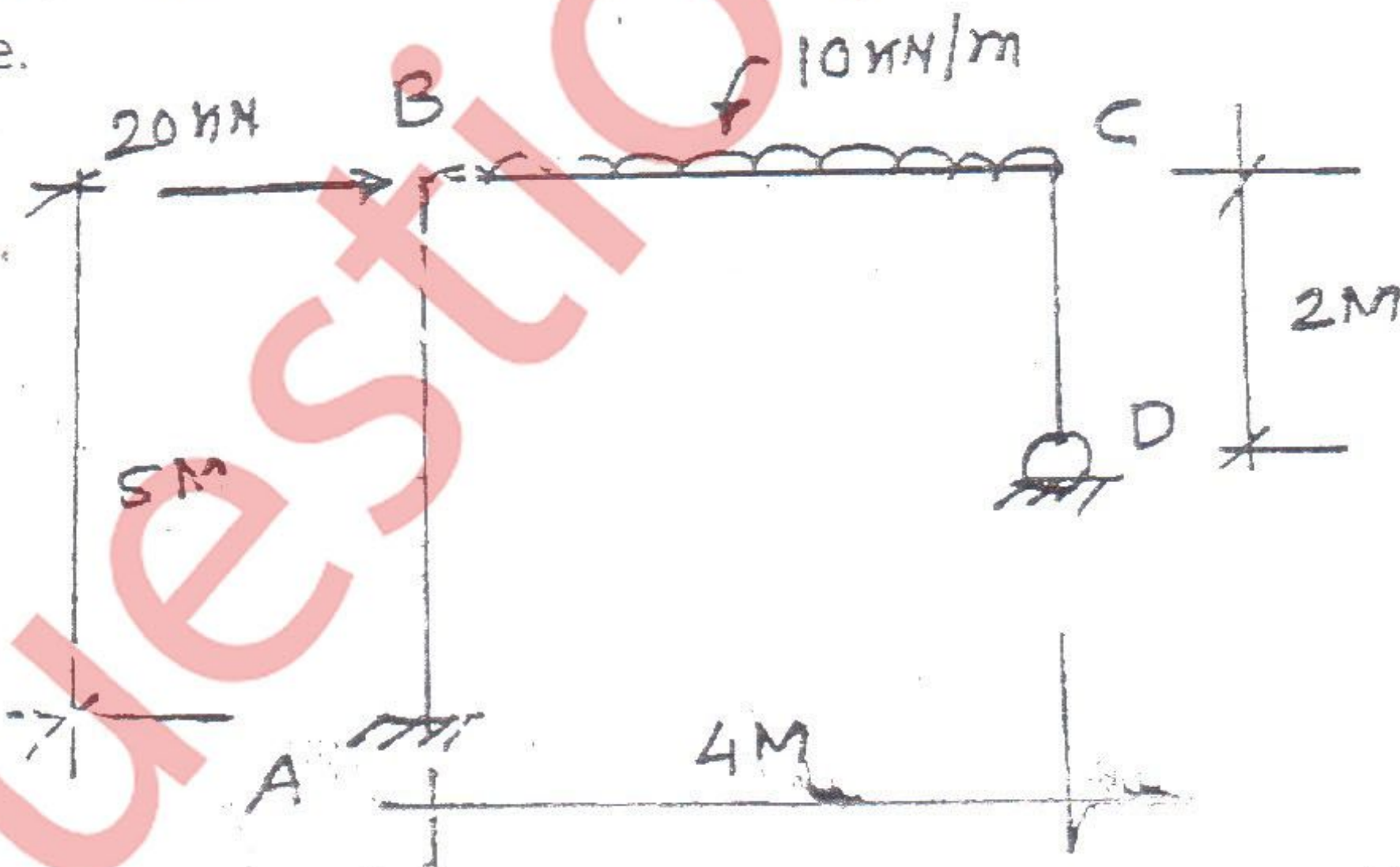

b) Analyse the beam by flexibility method and draw BMD (08)

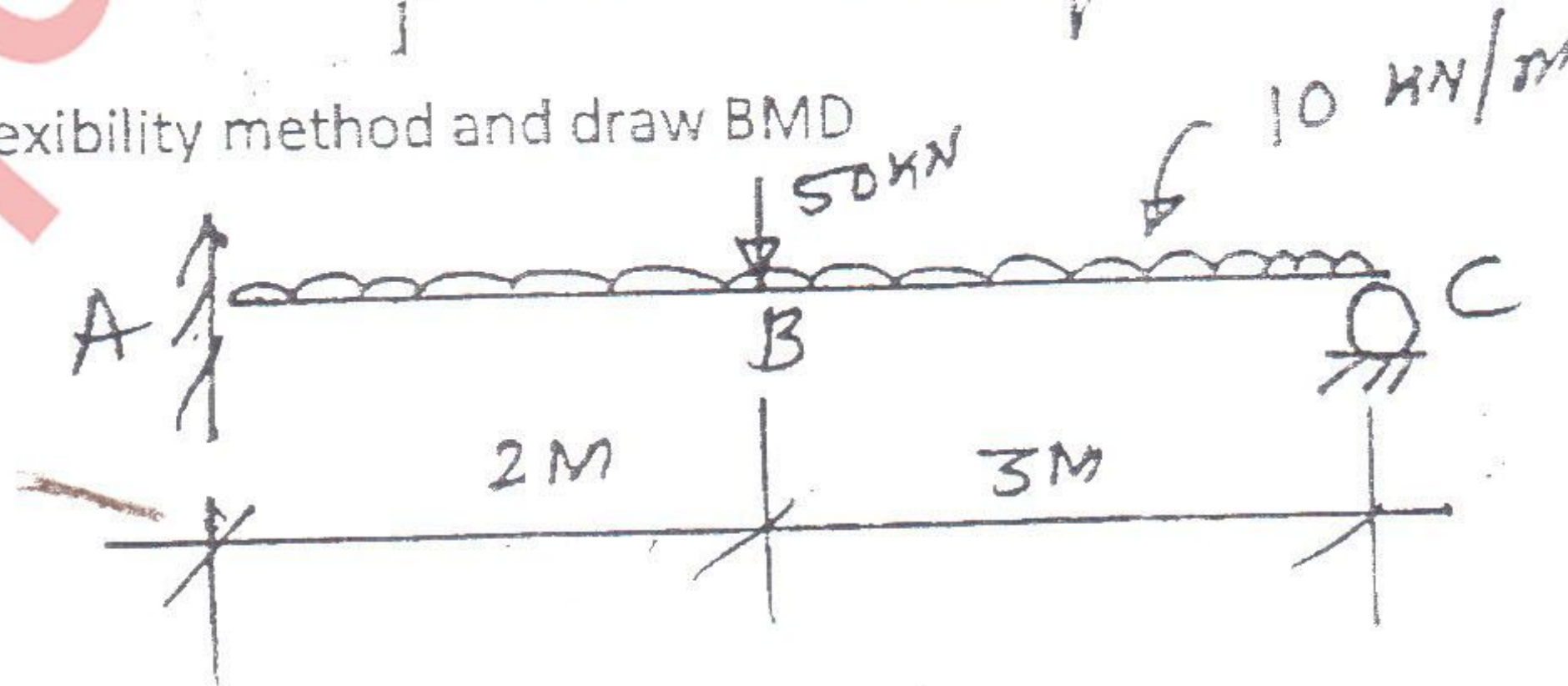

[TURN OVER

Q. No. 5 Analysis the rigid jointed plane frame as shown in figure, using Stiffness Method. Draw BMD, SFD and deflected shape. (12)

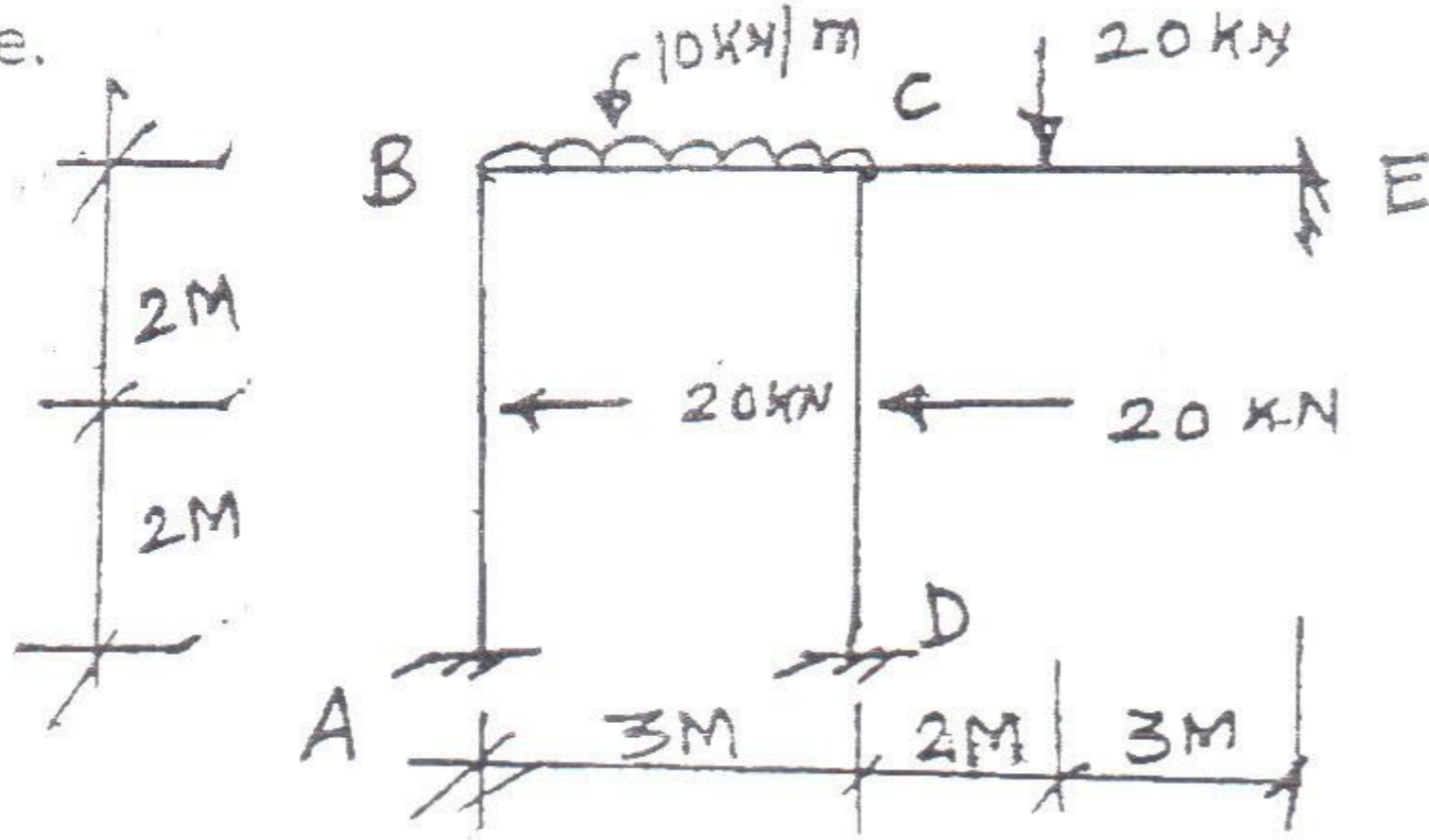

b) Calculate the plastic moment capacity required for the continuous beam with working load as shown in figure. (08)

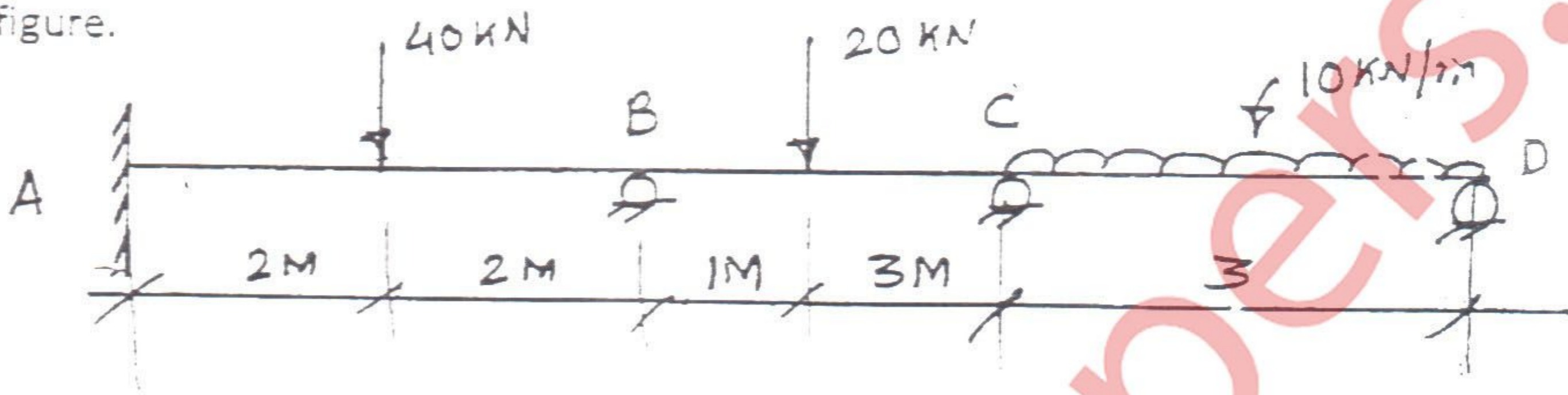

Q. No. 6 a) Analysis the pin jointed plane frame shown in figure and calculate the forces in all members. Take AE constant. (12)

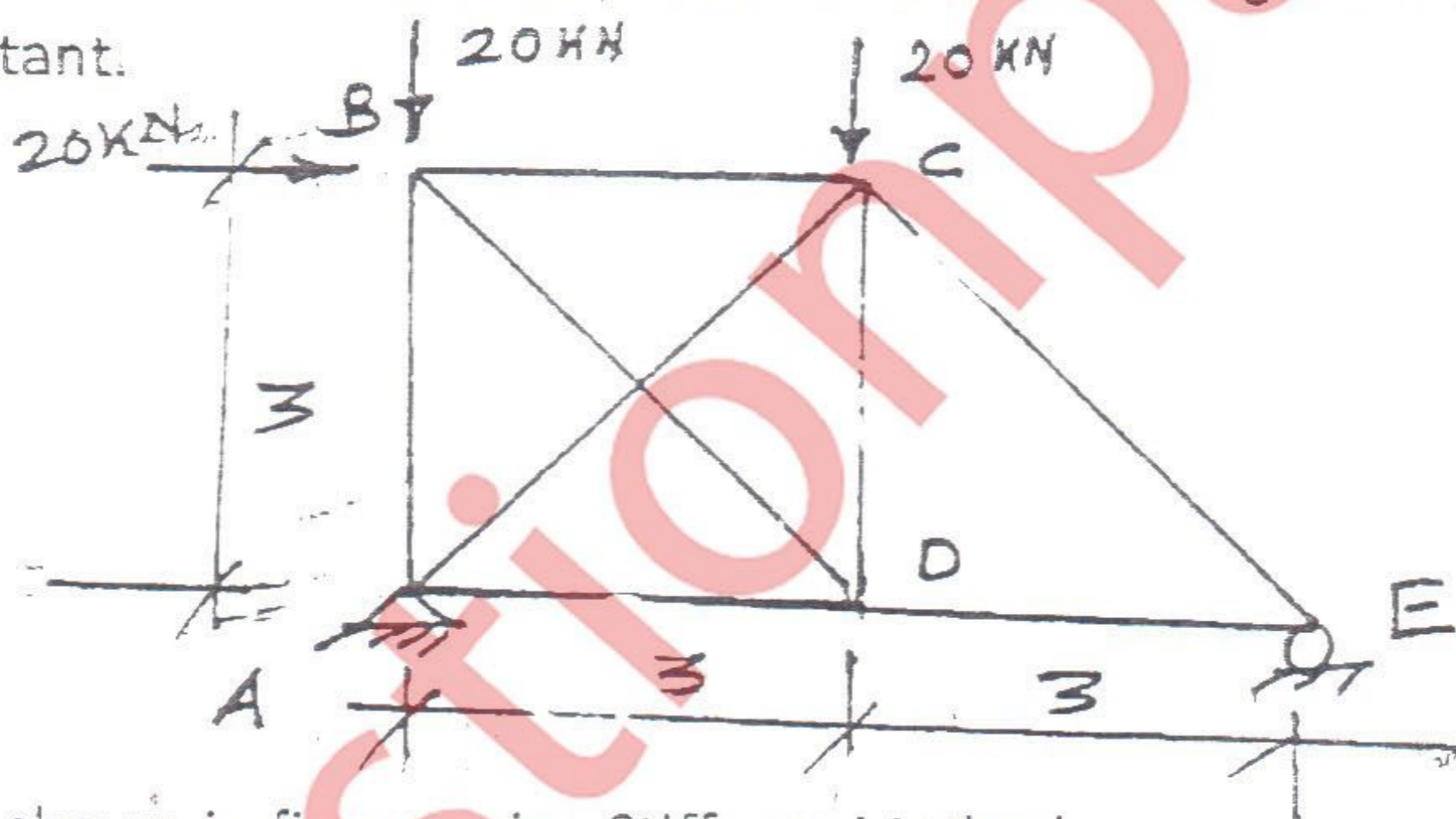

b) Analyze the beam as shown in figure using Stiffness Method. (08)

