

(3 Hours)

[Total Marks:80]

- N.B. 1. Question no. 1 is compulsory.
 2. Attempt ANY THREE questions out of remaining FIVE questions.
 3. Illustrate your answer with neat sketch wherever necessary.
 4. Figures to the right indicate full marks.

- Q1. Attempt any FOUR of the followings: (20)
- Degrees of freedom for planar manipulator
 - D-H parameters representation for planer 3R manipulator
 - Robot vision system
 - Legged locomotion and balancing in humanoids
 - Robots applications in automotive industry
- Q2. a) Draw the sketch of robotic system and explain various components of it. (10)
 b) Explain the terms direct and inverse kinematics of robots. Obtain the direct kinematics model for two-joint serial manipulator as shown in Fig. 1. (10)

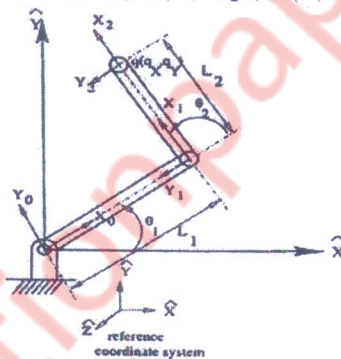

Fig.1 Two link serial manipulator

- Q3. a) A SCARA robot is shown in Fig. 1 along with axes and other parameters. (12)
 Find D-H parameters and final transformation matrix of end effector.

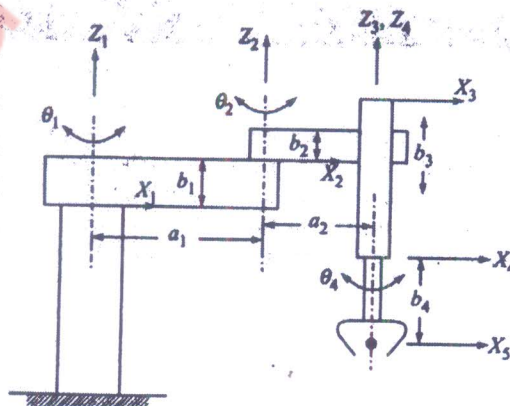

Fig. 1 A SCARA robot

- b) State the principles of materials handling system? Also discuss about important considerations while designing the materials handling system for a steel plant. (8)

- Q4. a) Discuss on sound and speech generation technologies for humanoids. (8)
b) Classify the various types of sensors used in robotics and explain construction, working principle and applications of any one displacement sensor. (8)
c) Explain the relationship between Joint space technique and Cartesian space technique in trajectory planning. (4)
- Q5. a) Discuss about the motion control system for mobile robot. (7)
b) Explain the construction, working principle and applications of stepper motor. (7)
c) Define the term workspace analysis. Sketch the work envelop of 5 axis articulated robot. (6)
- Q6. Write a short notes on the followings (ANY FOUR) (20)
a) Automated Guided Vehicle System (AGVS)
b) Bar code technology
c) Interfacing of electronic devices to micro-controller
d) Humanoid motion capturing technologies.
e) Social aspects and future challenges for humanoid robots
