

Machine Design - I
Mechanical/Automobile
(3 Hours)

QP Code :601100

[Total Marks: 80]

- Instructions: 1) Question No. 1 is compulsory
2) Answer any *three* from the remaining five questions
3) Use of recommended *PSG Design data book* is permitted.
4) Use your judgment for unspecified data, if any.

Q. No 1. Answer any **four** of the followings:

(20)

- a) Suggest with justification the suitable materials for the following components:
i) Flat-belt pulley ii) lathe bed iii) Connecting rod in I.C engine
iv) Flywheel
- b) Explain the difference between the bearing pressure and the contact stress with suitable examples.
- c) What is service factor ?. State its significance.
- d) Explain the following theories of failures:
i) Maximum normal stress theory ii) Octahedral shear stress theory
- e) Why square threads are used for power transmission and V-threads for fasteners ?
- f) Explain the S-N curve for fatigue life.

Q.2 a) A knuckle joint is subjected to an axial load of 140 kN. Design the knuckle joint taking the load to be uniformly distributed over the pin in the eye and uniformly varying over the portion of pin in forks. Use the following data:

(12)

Allowable tensile and compressive stress = 85 N/mm^2

Allowable shear stress = 45 N/mm^2

Allowable crushing stress = 150 N/mm^2

Thickness of eye = $1.5 \times$ pin diameter

Total fork thickness = eye thickness.

b) A bracket is riveted to a column by 6 rivets of equal size as shown in figure 1. It carries a load of 50 kN at a distance of 175 mm from the centre of the column. If the maximum shear stress in the rivet is limited to 150 MPa., determine the diameter of the rivet.

(8)

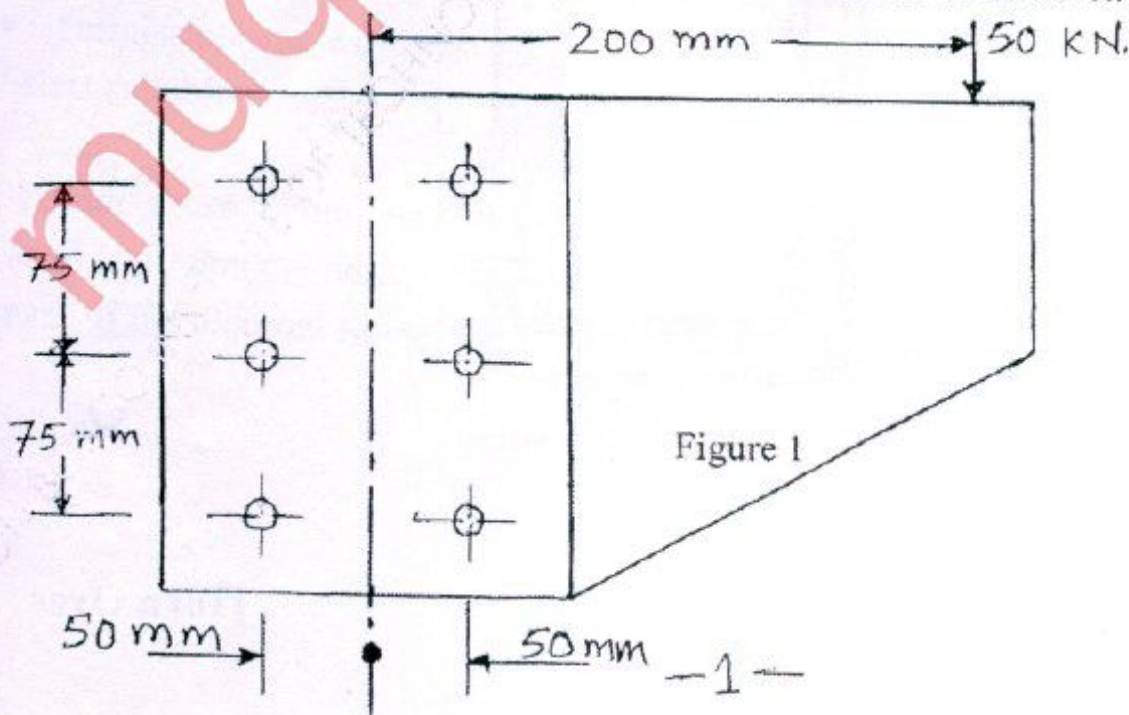

[Turn Over

- Q.3 a) An open 'S' link made of plain carbon steel 55C8 ($S_{yt} = 399 \text{ N/mm}^2$) is shown in figure 2. Calculate the dimensions of the link, if the factor of safety is 6. (7)

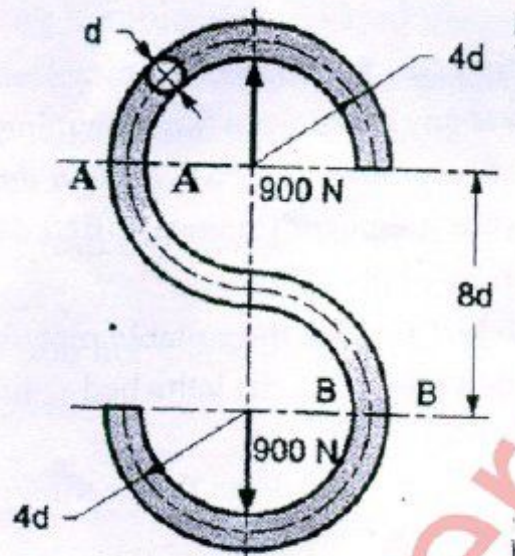

Figure 2

- b) A Machine press screw as shown in figure 3 is subjected to an axial force of 40 kN. Overhang of horizontal member of frame is 400 mm and height of screw is 500 mm. (13)

- Select the suitable material and stresses for screw, nut and frame.
- Design screw and nut,
- Check the screw for buckling failure.
- Determine the dimensions of cross-section of horizontal member of frame.

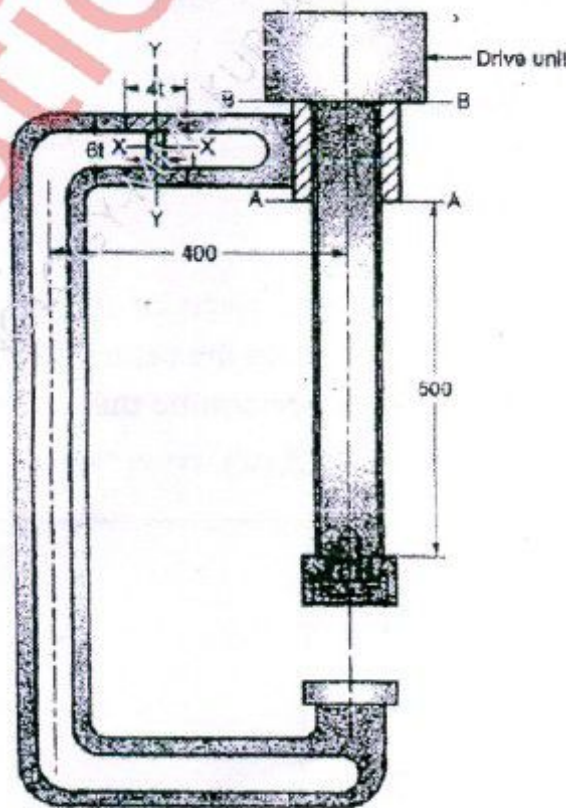

Figure 3

[Turn Over

- Q.4 a) A 60 mm diameter solid shaft is welded to a flat plate as shown in figure 4. If the size of the weld is 15 mm, find the maximum normal and shear stress in the weld. (10)

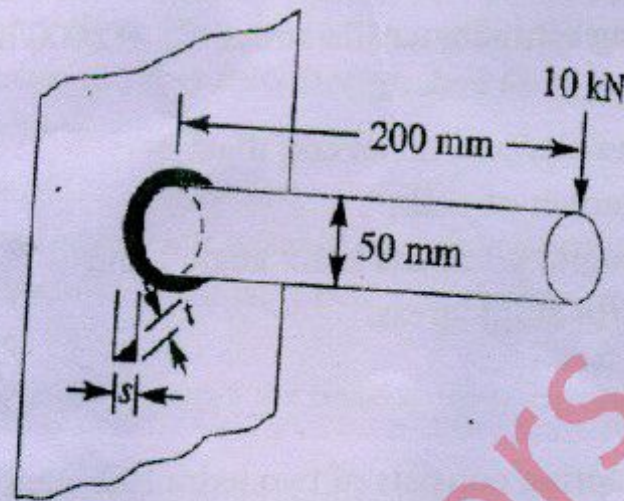

Figure 4

- b) The most critical point of component made of steel C40 is subjected to the following variable stresses. Determine the factor of safety based on Soderberg criterion and Octahedral shear stress theory. (10)

$$\sigma_x - \text{varies from } +12 \text{ to } -10 \text{ N/mm}^2$$

$$\sigma_y - \text{varies from } +14 \text{ to } +6 \text{ N/mm}^2 \text{ and}$$

$$\tau_{xy} - \text{varies from } +10 \text{ to } -10 \text{ N/mm}^2$$

- Determine the factor of safety based on Soderberg criterion and Octahedral shear theory.

- Q.5 a) Design the hollow shaft from the strength and rigidity considerations with following data:

- Power to be transmitted = 50 kW at 1440 r.p.m.
- Ratio of inner to outer diameter = 0.5
- Overhang = 250 mm
- Bending load = 18 kN
- Permissible angle of twist = 0.5°

Select suitable material

(12)

- b) A $16 \times 10 \text{ mm}^2$ cross-section parallel key is to be used to transmit 55 kW power at 1440 r.p.m. from a shaft of 40 mm diameter. The key is made of plain carbon steel with yield strength of 300 N/mm^2 . If the required safety margin is 3, determine the key length. (8)

Q.6 a) A helical compression spring is subjected to a load varying from zero to a maximum of a 9 kN with corresponding deflection of 90 mm. Considering average service with and spring steel having ultimate tensile stress, $S_{ut} = 2000/d^{0.16}$ N/mm² and $G = 80 \times 10^3$ N/mm², determine:

- i) wire diameter and mean coil diameter;
- ii) total number of coil ;
- iii) free length, pitch and helix angle ; and
- iv) check for solid stress.

(10)

b) A semi-elliptic leaf spring consists of two extra full length leaves and eight graduated leaves, including the master leaf. The centre to centre distance between the two eyes of the spring is 1.1 m. The maximum force acting on the spring is 12 kN and the width of each leaf is 60 mm. The spring is pre-stressed so as to equalize stresses in all leaves. If the stress induced corresponding to maximum load is equal to 350 N/mm² and modulus of elasticity of leaf spring is 200 GPa. Determine :

- i) The thickness of leaves;
- ii) The deflection of spring at maximum load ; and
- iii) The initial nip.

(4)

(3)

(3)