

(3 Hours)

[Total Marks ; 80]

- N.B. 1) Question No. 1 is compulsory  
2) Answer any Three questions from remaining Five  
3) Assume suitable data wherever required, justify the same  
4) Answer to questions showed be grouped and written together.

Qu. 1 Solve any Four

(20)

- What is the condition for self locking and self energizing of the belt?
- Where and for what purpose a clutch is used? What are the different types of clutches? Explain the working of any one type of clutch.
- Explain epicyclic gear train.
- Define dynamically equivalent systems. State the condition necessary to make two systems dynamically equivalent.
- Describe the gyroscopic effect on sea going vessels.
- What is the function of governor? Classify governor.

Qu. 2 a) If capacity of a single plate clutch decreases by 13% during the initial wear period, determine the minimum value of ratio of internal diameter to external diameter for the same axial load. Consider both the sides of the clutch plate to be effective. (10)

b) The upper arm of porter governor are pivoted on the axis of rotation, their lengths being 30cm. the lower arms are pivoted on the sleeve at a distance 3 cm from the axis, their lengths being 27cm. Mass of each ball is 6 kg and the sleeve mass is 50 kg. Determine the equilibrium speed for a radius of rotation of 17 cm and also the effort and power for 1% change of speed. (10)

Qu. 3 a) A vehicle moves on a road that has a slope of  $15^\circ$ . The wheel base and the Centre of mass at 0.72 m from the rear wheels and 0.8m above the inclined plane. The speed of the vehicle is 45 km/hr. the brakes are applied to all the four wheels and the coefficient of friction is 0.4. Determine the distance moved by the vehicle before coming to rest and the time taken to do so if it moves (i) up the plane (ii) down the plane. (10)

b) In a Hartnell governor, the radius of rotation of the balls is 60mm at the minimum speed of 240rpm. The length of the ball arm is 130mm and of the sleeve arm 80mm. the mass of each ball is 3kg and of the sleeve 4 kg. The stiffness of the spring is 20 N/mm. Determine (i) The speed when the sleeve is lifted by 50 mm. (ii) the initial compression of the spring. (iii) The governor effort. (iv) The power. (10)

[TURN OVER]

Qu. 4 a) Derive an expression for finding "angle of heel" of a two wheeler negotiating a turn. (10)

b) A cast iron flywheel is required to absorb 25000 N-m of energy as speed is increased from 120 to 125 rpm. If wheel is to be solid disc having a diameter 8 times the thickness. Determine its diameter. Density of C.I.=7200 kg/m<sup>3</sup>. (10)

Qu. 5 a) A horizontal gas engine running at 200 rpm has a bore of 210 mm and a stroke of 420 mm. The connecting rod is 924 mm long and the reciprocating parts weigh 18 kg. when the crank has turned through an angle of 30° from the inner dead center, the gas pressures on the cover and the crank sides are 500 kN/m<sup>2</sup> and 60 kN/m<sup>2</sup> respectively. Diameter of the piston is 40mm. Determine (i) turning moment on the crank shaft. (ii) thrust on the bearings. (iii) acceleration of the flywheel which has a mass of 8 kg and radius of gyration of 600 mm while the power of engine is 22 kW. (10)

b) in an epicyclic gear train as shown in Fig. 1, the wheel C is keyed to shaft B and wheel F is keyed to shaft A. the wheels D and E rotate together on a pin fixed to arm G. the number of teeth on wheels C, D, E and F are 35, 65, 32 and 68 respectively.

If the shaft A rotates at 60 rpm and shaft B rotates at 28 rpm in opposite direction, find the speed and direction of rotation of arm G. (10)

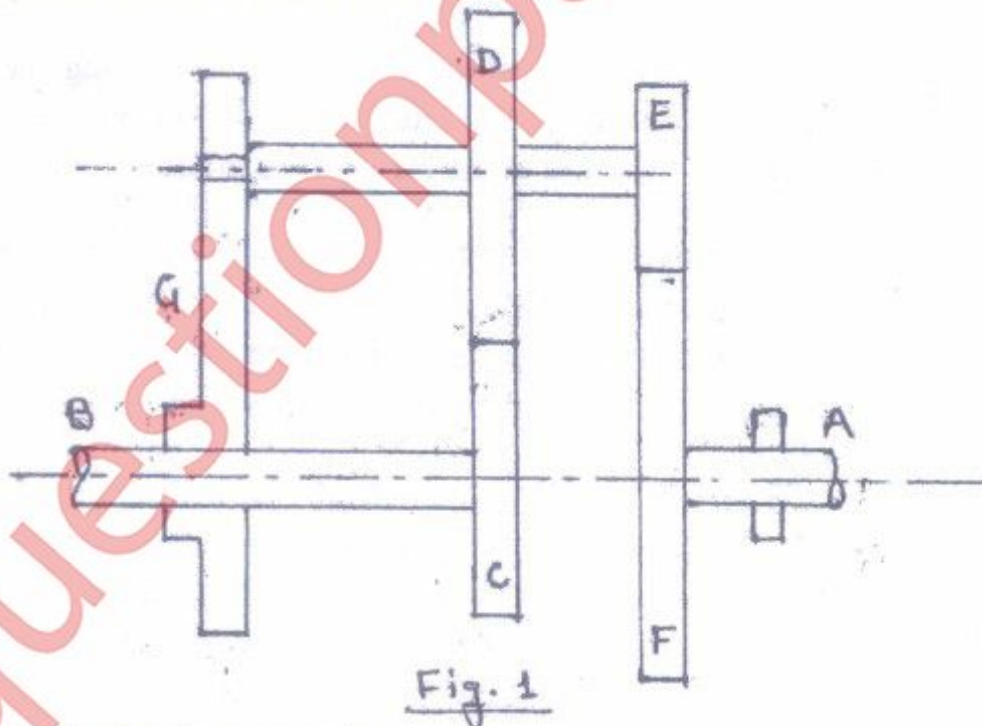

Qu. 6 a) Explain Rope brake dynamometer. (05)

b) Write a note on Co-efficient of insensitiveness of governors. (05)

c) A multi-plate clutch transmits 55 KW of power at 1800 rpm. Coefficient of friction surface is 0.1. Axial intensity of pressure is not to exceed 160 kN/m<sup>2</sup>. The internal radius is 80mm and is 0.7 times the external radius. Find the number of plates needed to transmit the required torque. (10)