

## Mechanical/Automobile

QP Code : 3254

(3 Hours)

[ Total Marks : 80

- N. B. :** (1) Question No.1 is compulsory.  
(2) Answer any **three** questions from remaining **five** questions.  
(3) Assume suitable data wherever required but justify the same.  
(4) Answer to the questions showed be grouped and written together.

1. Answer any **four** questions :-

- (a) Why single plate clutches are dry whereas multi plate clutches are wet? **20**
- (b) Prove that sensitiveness of a proell governor is greater than that of porter governor.
- (c) Explain self-energizing and self-locking effect in block brake.
- (d) Explain the necessity of gear box in automobile.
- (e) Derive the expression to determine gyroscopic couple.

2. (a) A leather faced conical clutch has a cone angle of  $30^\circ$ . If the intensity of pressure between the contact surfaces is limited to  $0.35 \text{ N/mm}^2$  and the breadth of the conical surface is not to exceed one-third of the mean radius, find the dimensions of the contact surfaces to transmit  $22.5 \text{ KW}$  at  $2000 \text{ rpm}$ . Assume uniform rate of wear and take coefficient of friction as  $0.15$ . **10**

(b) In case of band and block there are 10 blocks. The coefficient of friction is  $0.4$ . Each block subtends an angle of  $16^\circ$  with the centre of the wheel. The brake absorbs  $225 \text{ Kw}$  at  $300 \text{ rpm}$ . The effective diameter is  $80 \text{ cm}$ . Find the force applied at the end of lever  $25 \text{ cm}$  long if band is attached at a distance of  $15 \text{ cm}$  and  $3 \text{ cm}$  either side of the fulcrum. **10**

3. (a) In the epicyclic gear train shown in Fig. 1, a gear C which has teeth cut internally and externally is free to rotate on an arm driven by the shaft  $S_1$ . It meshes externally with the casing D and internally with the pinion B. The gears have following number of teeth:  $T_B=24$ ,  $T_C=32$  and  $T_D=48$ , Find the velocity ratio between (i)  $S_1$  and  $S_2$  when D is fixed. **12**

(ii)  $S_1$  and D when  $S_2$  is fixed. What will be the torque required to fix the casing D if a torque of 300Nm is applied to shaft  $S_1$ ?

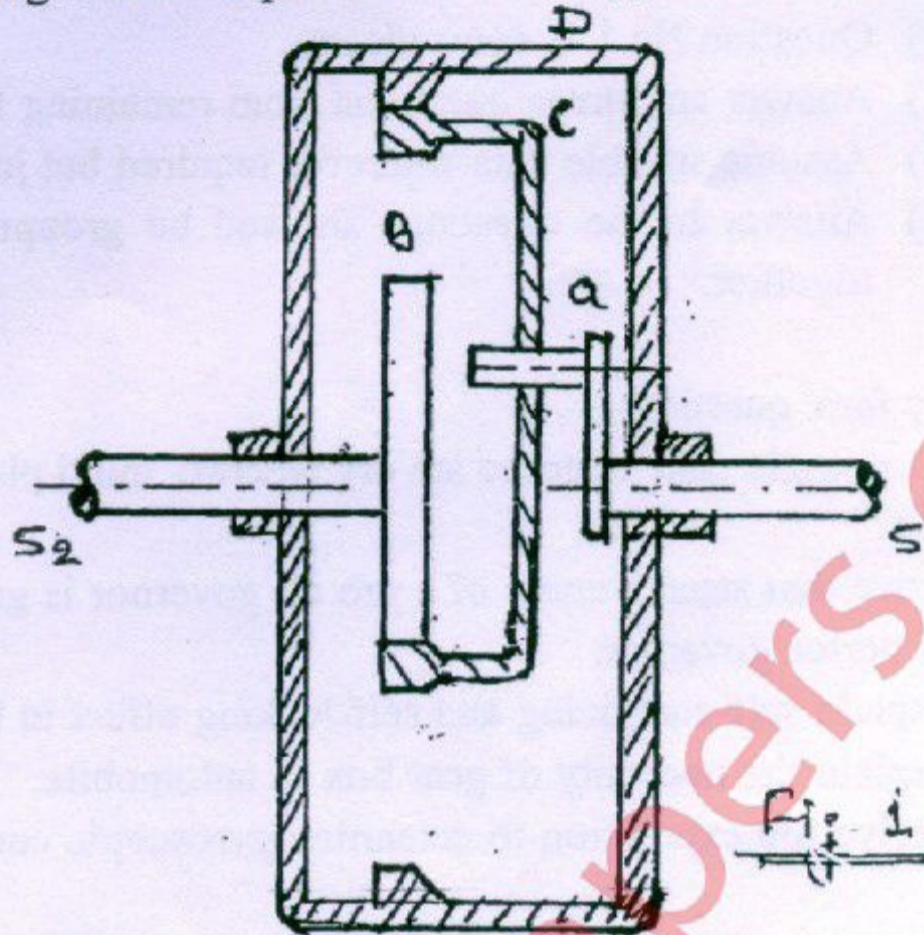

(b) Derive an expression for finding 'angle of heel' of a two wheeler negotiating a turn. 8

4. (a) A horizontal gas engine running at 210 rpm has a bore of 220mm and a stroke of 440mm. The connecting rod is 924mm long and the reciprocating parts weight 20Kg. when the crank has turned through an angle of  $30^\circ$  from the inner dead center, gas pressure on the cover and the crank sides are  $500\text{KN/m}^2$  and  $60\text{KN/m}^2$  respectively. Diameter of the piston rod is 40mm. Determine (i) turning moment on crank shaft. (ii) thrust on the bearing. (iii) acceleration of the flywheel which has a mass of 8 Kg and radius of gyration of 600mm while the power of engine is 22Kw. 12

(b) Single plate clutch transmits 25 Kw at 900rpm. The maximum pressure intensity between the plates is  $85\text{KN/m}^2$ . The outer diameter of the plate is 360mm. Both sides of the plate are effective and the coefficient of friction is 0.25. 8

Determine the (i) Inner diameter of the plate (ii) Axial force to engage the clutch

5. (a) The arms of Hartnell governor are of equal length. When the sleeve is in the mid position, the masses rotate in a circle with diameter of 150mm (the arms are vertical in the mid position). Neglecting friction, the equilibrium speed for this position is 360rpm. Maximum variation of speed taking friction into account, is to be 6% of the mid position speed for a maximum sleeve movement of 30mm. The sleeve mass is 5 Kg and the friction of sleeve is 35N. Assuming that the power of the governor is sufficient to overcome the friction by 1% change of speed on each side of mean position. Find (neglecting obliquity effects of the arms), the (i) mass of each rotating of ball. ii) spring stiffness. iii) initial compression of the spring. 12
- (b) State the different types of governors. What is the difference between centrifugal and inertia governors? Why is the former preferred to the later? 8
6. (a) Each wheel of four wheeled rear engine automobile has a moment of inertia  $2.4 \text{ Kg m}^2$  and an effective diameter of 660mm. The rotating parts of the engine have a moment of inertia of  $1.2 \text{ Kg m}^2$ . The gear ratio of engine to the back wheel is 3 to 1. The engine axis is parallel to the rear axle and the crankshaft rotates in the same sense as the road wheels. The mass of vehicle is 2200Kg and the centre of the mass is 550mm above the road level. The track width of the vehicle is 1.5m. Determine the limiting speed of the vehicle around a curve with 80m radius so that all the four wheels maintain contact with the road surface. 10
- (b) A riveting machine is driven by a constant torque 3KW motor. The moving parts including the flywheel are equivalent to 150Kg mass and 0.6m radius. One riveting operation takes one second and absorbs 10000 N-m of energy. The speed of flywheel is 300 rpm before riveting. How many rivets can be closed per minute? 10
-