

Instructions:

1. Question 1 compulsory.
2. Attempt any three questions from the remaining five questions.
3. Assume suitable data, if necessary.
4. Figures/sketches carry weightage.

- Q1) a) Determine the stability using Routh Hurwitz Criterion of the following characteristic equation: 05  
 $s^5 + s^4 + 2s^3 + 2s^2 + 3s + 15 = 0$
- b) Differentiate between open and closed loop systems with their respective block diagrams and examples 05
- c) Explain the following terms with respect to static characteristics of the measuring instruments: 05  
 I) Hysteresis II) Accuracy and Precision III) Resolution IV) Drift
- d) Explain the principle of LVDT with a neat sketch 05

- Q2) a) Convert the following state space system into a transfer function 10

$$X(t) = \begin{pmatrix} 0 & 1 & 0 \\ 0 & 0 & 1 \\ -3 & -2 & -5 \end{pmatrix} x(t) + \begin{pmatrix} 0 \\ 0 \\ 10 \end{pmatrix} u(t)$$

$$Y(t) = [1 \ 0 \ 0] x(t)$$

Here  $x(t)$  are state variables,  $u(t)$  is a force vector and  $y(t)$  being the system response

- b) Explain the construction and working of an Optical Pyrometer with a neat sketch 10
- Q3) a) A rectangular steel rod of width 'b' and depth 'd' is supported at its end and is loaded at its center by load 'W'. If the length of the rod between supports is 'l' and 'd<sub>m</sub>' where - 12  
 $d_m = \frac{Wl^2}{4Ebd^3}$

Where;

$$b = 4.942 \pm 0.42 \text{ cm ;}$$

$$d = 5.25 \pm 0.25 \text{ cm ;}$$

$$l = 1000 \pm 0.5 \text{ cm,}$$

$$d_m = 2.622 \pm 2.25\%$$

$$W = 1500 \text{ N.}$$

Find value of modulus of elasticity, % of uncertainty in various quantities, % of uncertainty in various quantities.

- b) For a unity feedback system having open loop transfer function, 08

$$G(s) = \frac{14(s+3)}{s(s+5)(s^2+2s+2)}$$

Determine (i) Type and order of the system (ii) All error coefficients

(iii) Steady state error for input  $1 + 4t + \frac{t^2}{2}$

- Q4) a) Prove Gauge factor,  $K = \frac{\Delta p / p}{\Delta L / L} + 1 + 2\nu$  10
- b) Enumerate the types of pressure measurement devices w.r.t. to pressure levels. Explain the construction and working of Bourdon tube with a neat sketch 10

Q5) a) Obtain transfer function  $C(s) / R(s)$  using block diagram reduction technique.

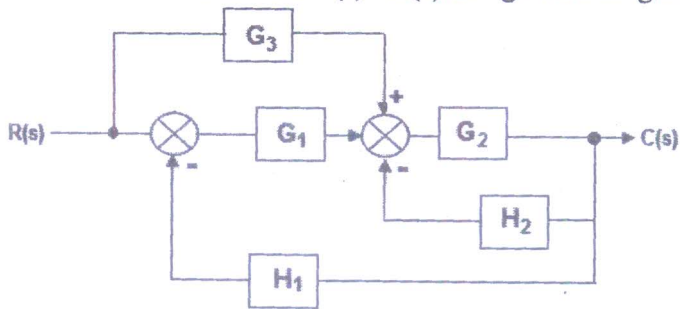

b) A feedback system has  $G(s) H(s) = 242 (s+5) / s (s^2 + 5s + 121) (s + 1)$ . Draw Bode plot and comment on its stability.

Q6) a) Sketch the Root Locus for the given system having  $G (s)$ .  $H (s) = K(s + 5) / (s^2 + 4s + 20)$ . Comment on its stability

b) Explain the construction and working of non contact type of speed measurement system with a neat sketch

\_\_\_\_\_