

- N.B. :** (1) Questions No. 1 is compulsory.
 (2) Attempt any **three** questions out of remaining **five** questions.
 (3) Assume **suitable** data if **necessary**.
 (4) Illustrate your answer with **neat sketches** wherever **necessary**.

1. Attempt any **four** :-

20

- Show that in metal cutting operation, $V_v = V_c \cdot \gamma_c$.
- Describe Radial drilling machine with neat sketch.
- Explain orthogonal rake system.
- Describe internal grinding machine with neat sketch.
- Discuss cutting fluids.

2. (a) Write a part programme using G-code and M code for machining external contour and drilling hole, at the centre as shown in figgur. All dimensions are in mm.

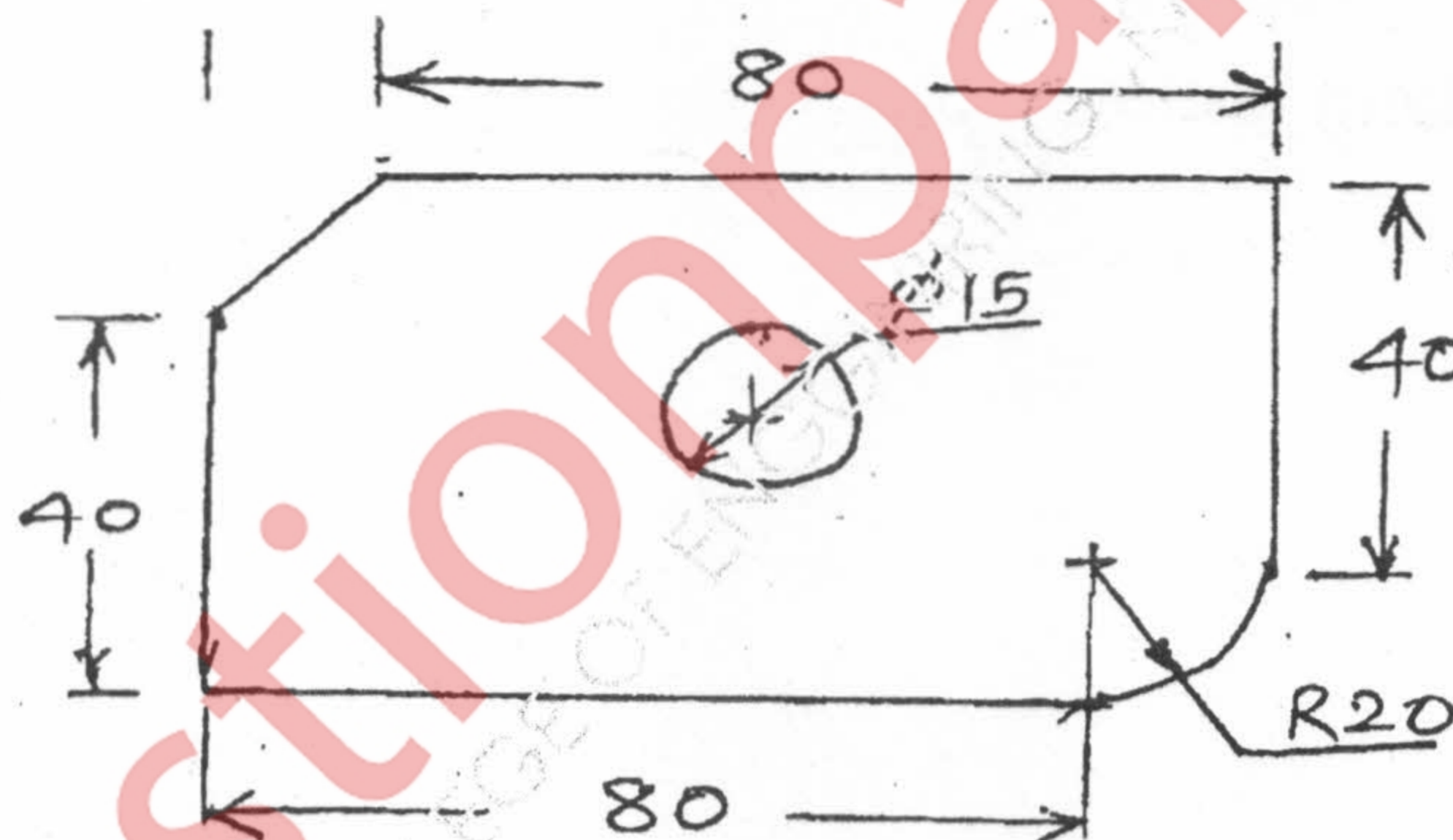

- Derive the relationship $2\phi + \beta + \gamma = \frac{\pi}{2}$ in merchant's theory, clearly stating the assumptions. 10
3. (a) Explain the various steps involved in designing circular pull type broach. Draw appropriate sketches. 10
 (b) Derive expression for tool life for minimum cost criteria in metal cutting. 10
4. (a) Describe carbides and ceramics as cutting tools. 10
 (b) Draw two dimensional tool dynamometer and explain it features. 5
 (c) List gear manufacturing methods explain any one in detail with neat sketch. 5

5. (a) Explain with an example, graphical method of designing form tool. 10
(b) A workpiece of 38 mm diameter is being turned on a lathe with a tool having rake angle of 33° and a feed of 0.15 mm/rev. The length of chip over one revolution of workpiece is 72 mm. The cutting speed is 12.5 m/min, the tangential force is 410 N and feed force is 170 N. Calculate :- 10
- (i) Coefficient of friction on a rake face
 - (ii) Thickness of chip
 - (iii) Velocity of shear
 - (iv) Velocity of chip along the tool face.
6. Write short notes on (any four) :- 20
- (a) Lapping and honing
 - (b) Dressing and truing of grinding wheel
 - (c) Co-ordinate measuring machine
 - (d) Nomenclature of drilling tool
 - (e) Geometry of Milling cutter.

GN-Con. 10554-14.