



Max. Time: 3 hr

Max. Marks: 80

Q.1 is compulsory (any Four). Attempt any 3 from Q.2 to Q.6

- 1(a) For the circuit shown in Fig.1, find the value of R if the circuit regulates at 6 V for the input supply voltage of 22 V. The zener diode currents are minimum 10mA and maximum 40mA. The load current I_L varies from 0 to V_{max} . What is the value of I_{Lmax} ? Also, find the power rating of the zener diode. (5)

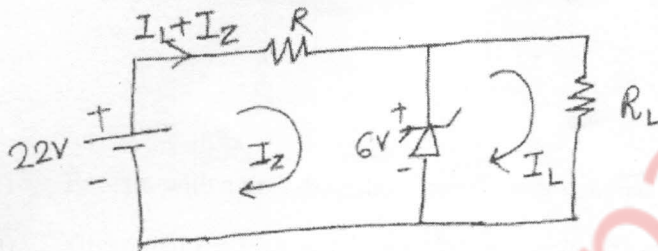

Fig. 1

- 1(b) Determine the I_B , I_C , V_{CE} , V_C and V_{BC} for the fixed-bias configuration of fig.2. (5)

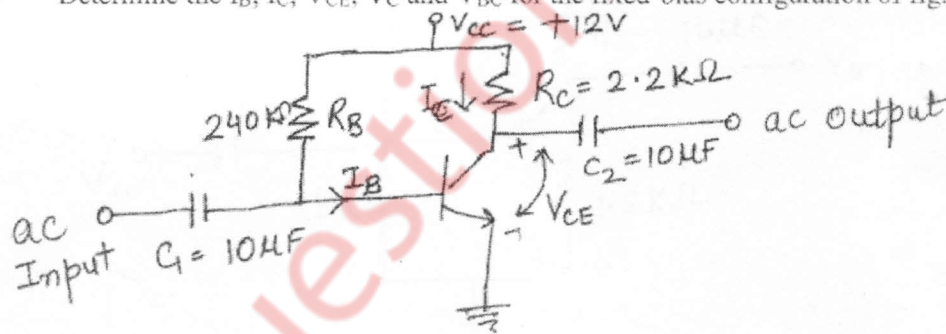
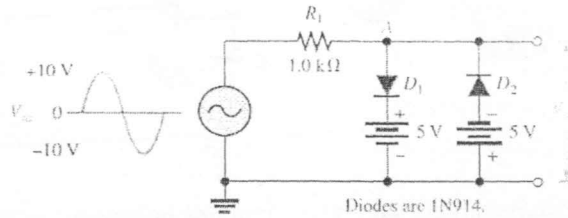

Fig. 2

- 1(c) Explain the term "Field Effect" in JFET. (5)

[TURN OVER

- 1(d) Draw and explain series voltage regulator. (5)
- 1(e) Define a filter. How are filters classified? (5)
- 2(a) Determine the output voltage waveform. (5)



- 2(b) Design a clamper to perform the function (5)

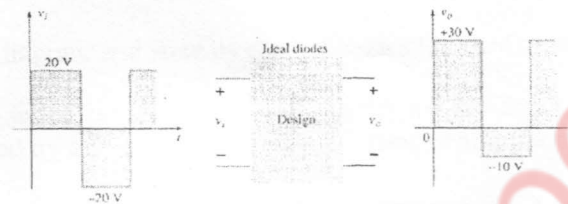

- 2(c) Explain with a neat diagram a transformer coupled audio power amplifier (10)
- 3(a) Given that $I_C = 2\text{mA}$ and $V_{CE} = 10\text{V}$, determine R_1 and R_C for the network shown in fig. below. (10)

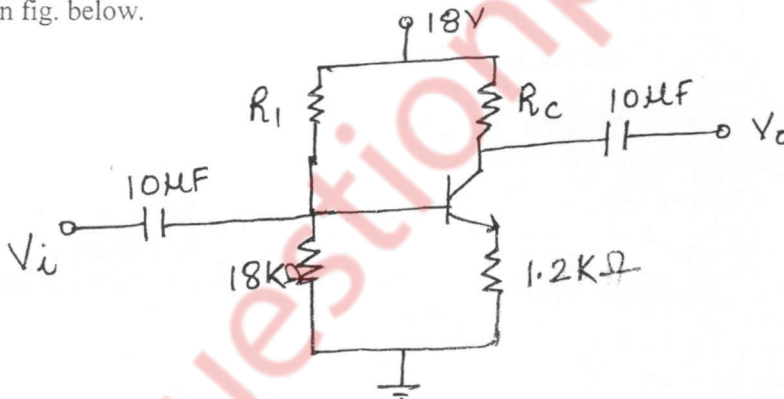

- 3(b) What do you understand by Thermal runaway? (5)
- 3(c) How transistors can be used as switches? (5)

[TURN OVER

- 4(a) Determine V_{GS} , I_D , V_{DS} for the fixed Bias configuration as shown in fig below. (10)

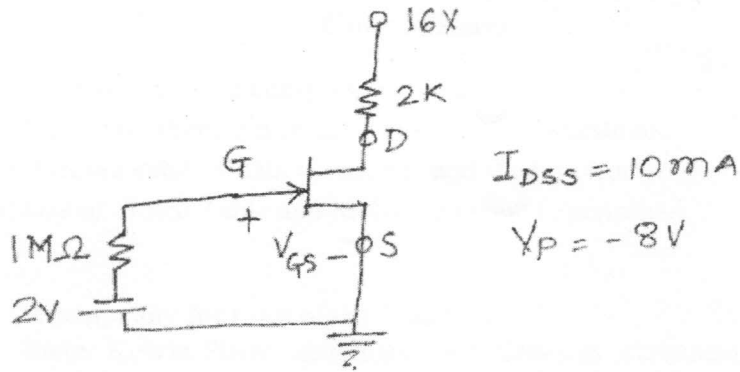

- 4(b) Explain the structure, operation and current-voltage characteristics of Enhancement type MOSFET. (10)
- 5(a) Draw the block diagram and state its characteristics for ideal op-amp. (5)
- 5(b) Design a scaling amplifier circuit that will amplify the first input by a factor of 3 and a second by a factor of 4. Use the inverting configuration for the same. (5)
- 5(c) Draw the circuit diagram for Integrator. Derive the necessary equations. Draw its frequency response. How the problems of basic integrator can be corrected. (10)
- 6(a) Write down the condition for oscillations. Draw the circuit for a Wein bridge oscillator and derive the expressions for frequency and gain. (10)
- 6(b) Using standard 5% resistances, design a circuit such that (10)

$$V_0 = -2(2v_1 + 3v_2 - 2v_3).$$