

- N.B. :** (1) Question No. 1 is **compulsory**.
 (2) Solve any **three** questions from QuestionsNos. 2 to 6.
 (3) Assume **suitable** data if **necessary**.

1. (a) Write a note on time constant in transient circuits. 4
 (b) Define pole and zero of a network function and draw p-z plot for 4

$$V(s) = \frac{3(s+1)}{(s+2)(s^2+4s+5)}$$

- (c) Write the Mesh questions for the circuit shown. 4

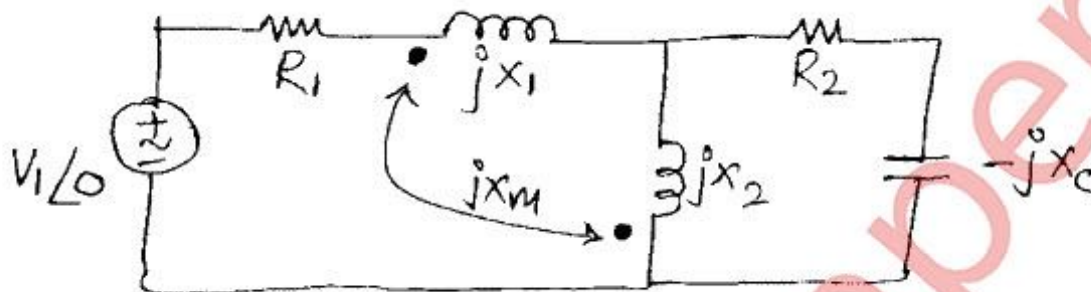

- (d) Derive the s – domain equivalents for inductor with initial current I_0 and capacitor with initial voltage V_0 4
 (e) What is network synthesis? Realize the network function 4

$$Y(s) = 4s + 9/s + \frac{15s}{s^2 + 4}$$

2. (a) Write incidence matrix, tieset matrix and cutset matrix for the graph shown, where (1), (3), (5) and (7) are links of the graph. 10

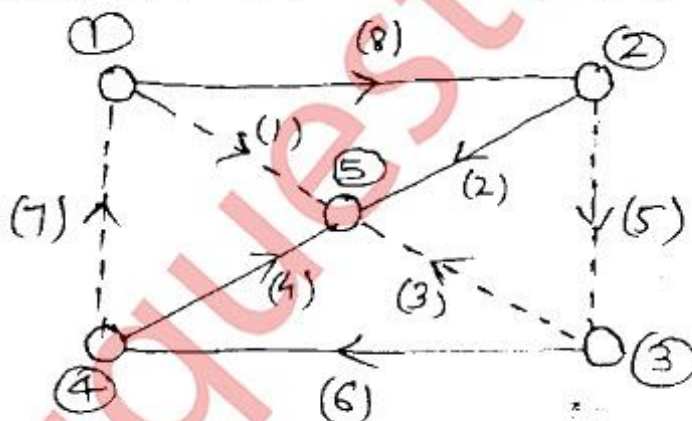

- (b) For the transient circuit shown, determine $i(t)$ for $t \geq 0$ using L.T. application. 6
 Also calculate $i(\infty)$.

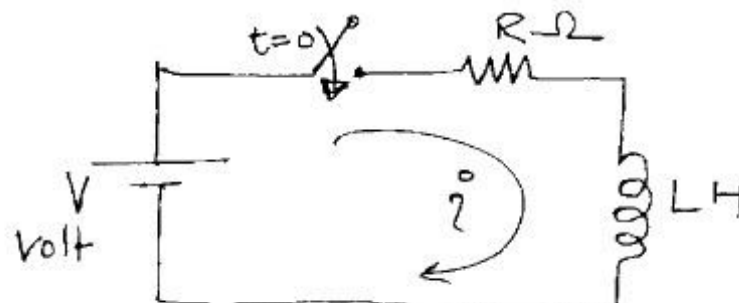

- (c) Explain Natural response and forced response. 4

Con. 9932-GX-12179-13.

2

3. (a) Determine loop currents at $t = 0+$ for the circuit shown.

10

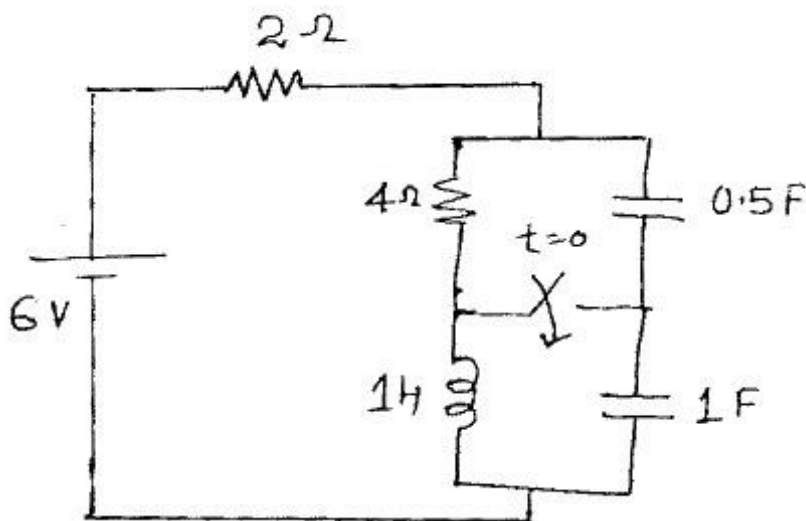

(b) Determine the L. T. of the gate function.

2

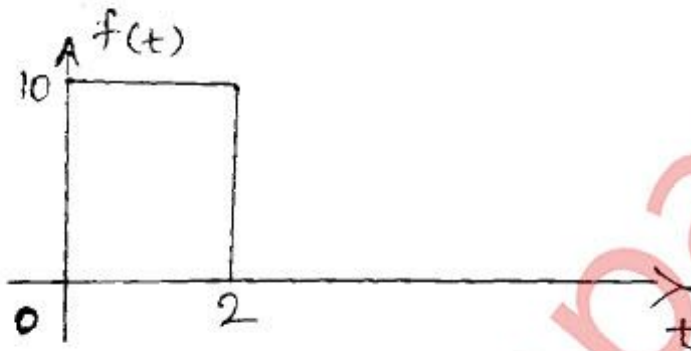
(c) Find Thevenin's equivalent across $a - a'$

8

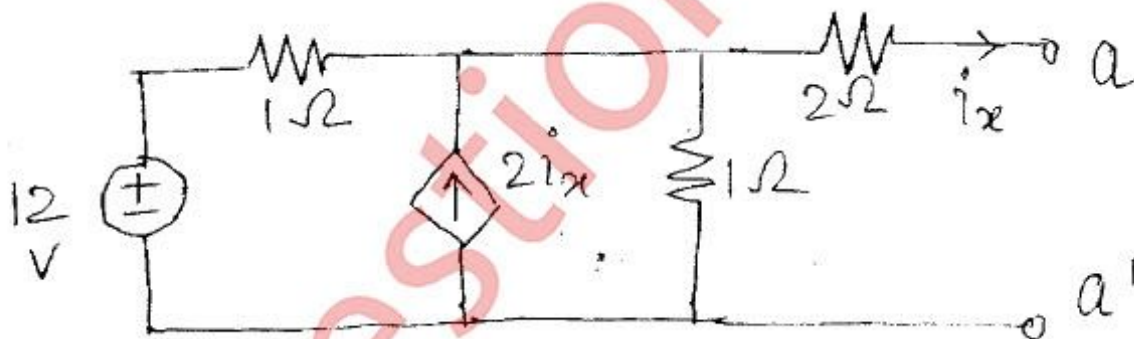

4. (a) State reciprocity theorem and verify the same for the circuit shown.

10

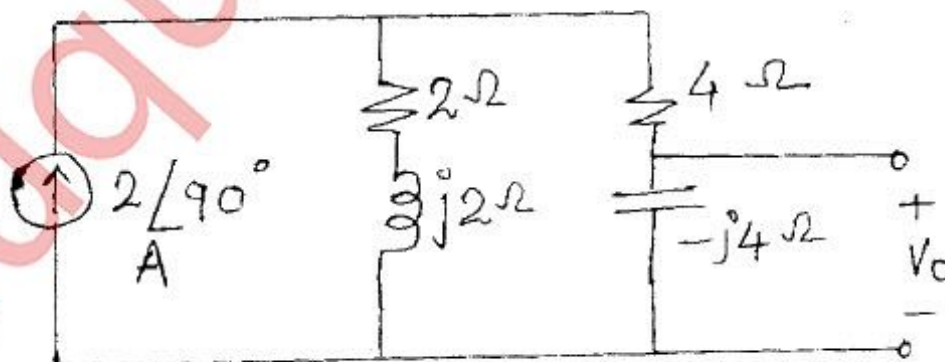
(b) Check the polynomial $P(s)$ for Hurwitz.

6

$$P(s) = s^3 + 4s^2 + 5s + 20$$

(c) Explain the principle of duality with example.

4

[TURN OVER

Con. 9932-GX-12179-13.

3

5. (a) For the network shown, the impedance function has p - z plot given below with $z(0) = 1$. Find the values of R, L and C. 8

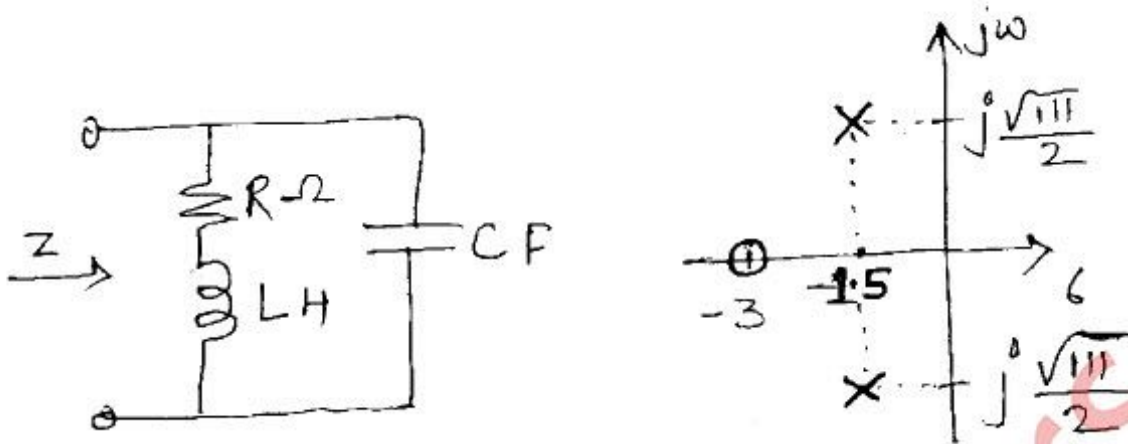

- (b) Realize the network function in F - I and F - II forms 10

$$Y(s) = \frac{s(s+2)(s+6)}{(s+1)(s+4)(s+8)}$$

- (c) Define Transmission parameters. 2

6. (a) Express h-parameters in terms of z-parameters and find z and h parameters for network shown. 10

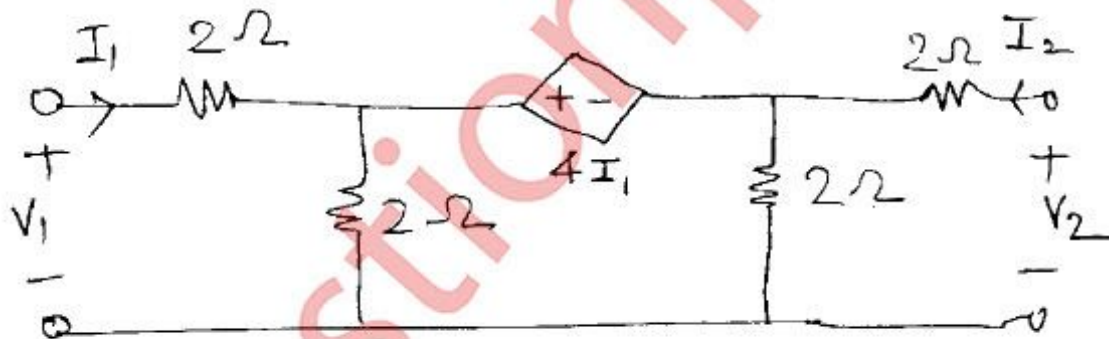

- (b) State and explain Millman's theorem. 6

- (c) Discuss in brief the significance of dot convention. 4
