

- N.B.:** 1. Question No 1 is compulsory  
 2. Attempt any **Three** questions from the remaining five questions.  
 3. Assume any **suitable data** if necessary with justification.  
 4. Figures to the right indicates max. marks

**Q.1.** Attempt any **four** of the following questions.

20

- Draw the shear force and bending moment diagram for a cantilever beam with uniformly distributed load and a concentrated load at the free end.
- A cantilever 3 m long carries a UDL over the entire length. Find the deflection at the free end if the slope at the free end is  $3^\circ$ .
- Derive the relation between E G K.
- Obtain an expression for strain energy stored due to torsion in a solid shaft.
- A bar of 12 mm in diameter is acted upon by an axial load of 20 KN. The change in diameter is measured as 0.003 mm. Determine (i) the Poisson's ratio and (ii) the modulus of elasticity and the bulk modulus. The value of modulus of rigidity is 80 GPa.

**Q.2 a)** A steel tube of 35 mm outer diameter and 30 mm inner diameter encloses a gun metal rod of 25 mm diameter and is rigidly joined at each end. If at a temperature of  $400^\circ\text{C}$  there is no longitudinal stress, determine the stress developed in the rod and the tube when the temperature of the assembly is raised to  $240^\circ\text{C}$ . Take,

10

Young's modulus for steel = 205 GPa,

Young's modulus for gun metal = 91.5 GPa

Coefficient of thermal expansion of steel =  $11 \times 10^{-6}/^\circ\text{C}$

Coefficient of thermal expansion of gun metal =  $18 \times 10^{-6}/^\circ\text{C}$ .

Also find the increase in length if the original length of the assembly is 1 m.

- Draw the shear force and bending moment diagram for a simply supported beam as shown in the figure.

10

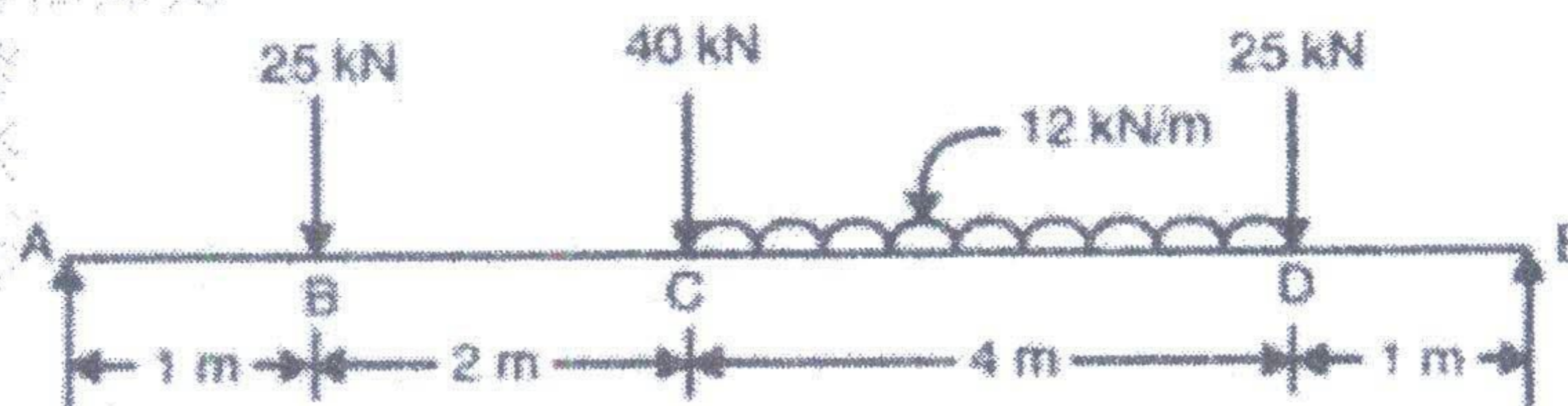



Q.3 a) The tension flange of a girder of I-section is 240 mm X 40 mm, whereas the compression flange 120 mm X 20 mm. The web is 300 mm deep and 20 mm thick. If the girder is used as simply supported beam of 8 m span, determine the load per m run if the allowable stress is 90 MPa in compression and 30 MPa in tension. 10

b) A hollow cast iron column whose outside diameter is 300 mm has a thickness of 30 mm. It is 5 m long and fixed at both ends. Calculate the safe load of Rankine formula using a factor of safety 4. Calculate the slenderness ratio and ratio of Euler's critical load to Rankine's critical load.

Take  $\sigma_c = 550 \text{ N/mm}^2$  and  $\alpha = 1/1600$  in Rankine's formula.

Also take  $E = 8 \times 10^4 \text{ N/mm}^2$  10

Q.4a) A hollow shaft of diameter ratio  $3/8$  is to transmit 600 kW at 110 rpm. The maximum torque being 20% greater than mean. The shear stress is not to exceed  $63 \text{ N/mm}^2$  and twist in a length of 3 m is not to exceed 1.4 degrees. Calculate the external and internal diameters which would satisfy both the above conditions. Take  $G = 8 \times 10^4 \text{ N/mm}^2$  10

b) Figure below shows a rectangular plate with a hole drilled in it. Determine the greatest and the least intensities of stress at the critical section of the plate when subjected to an axial pull of 90 kN. 10

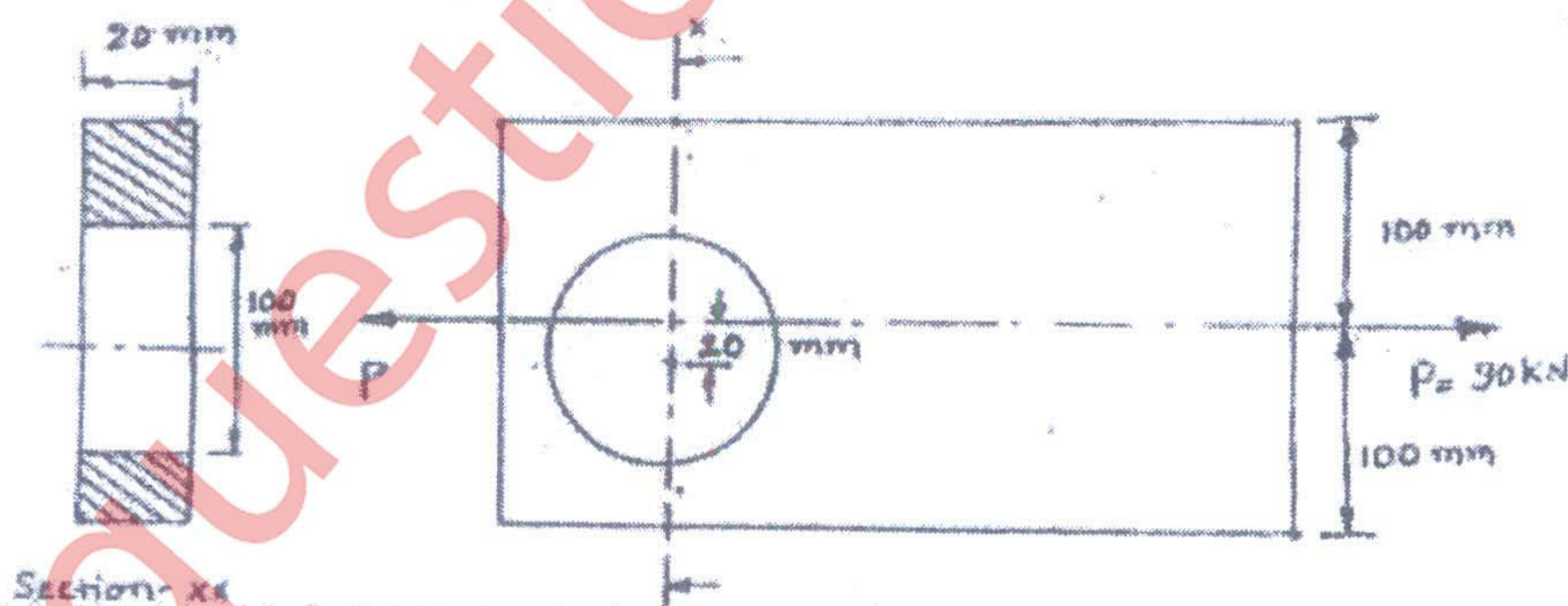

Q.5 a) A simply supported beam is subjected to the loads as shown in the figure. Determine the maximum deflection induced in the beam. Take value of  $EI = 1.2 \times 10^5 \text{ N-m}^2$ . 10

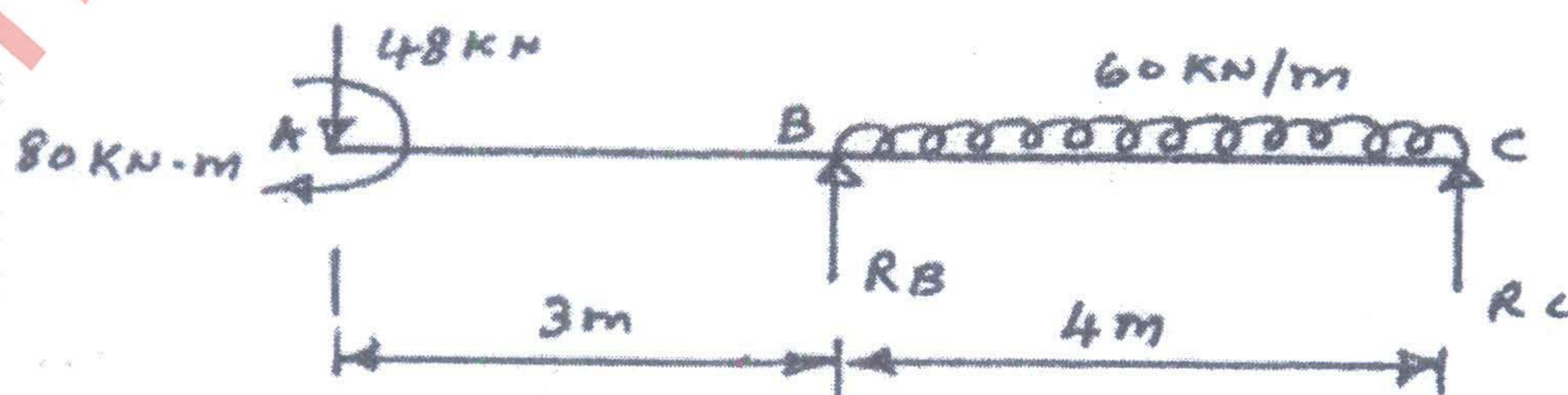



b) Draw shear stress variation diagram for a beam section shown in figure. Take SF=100KN.

10

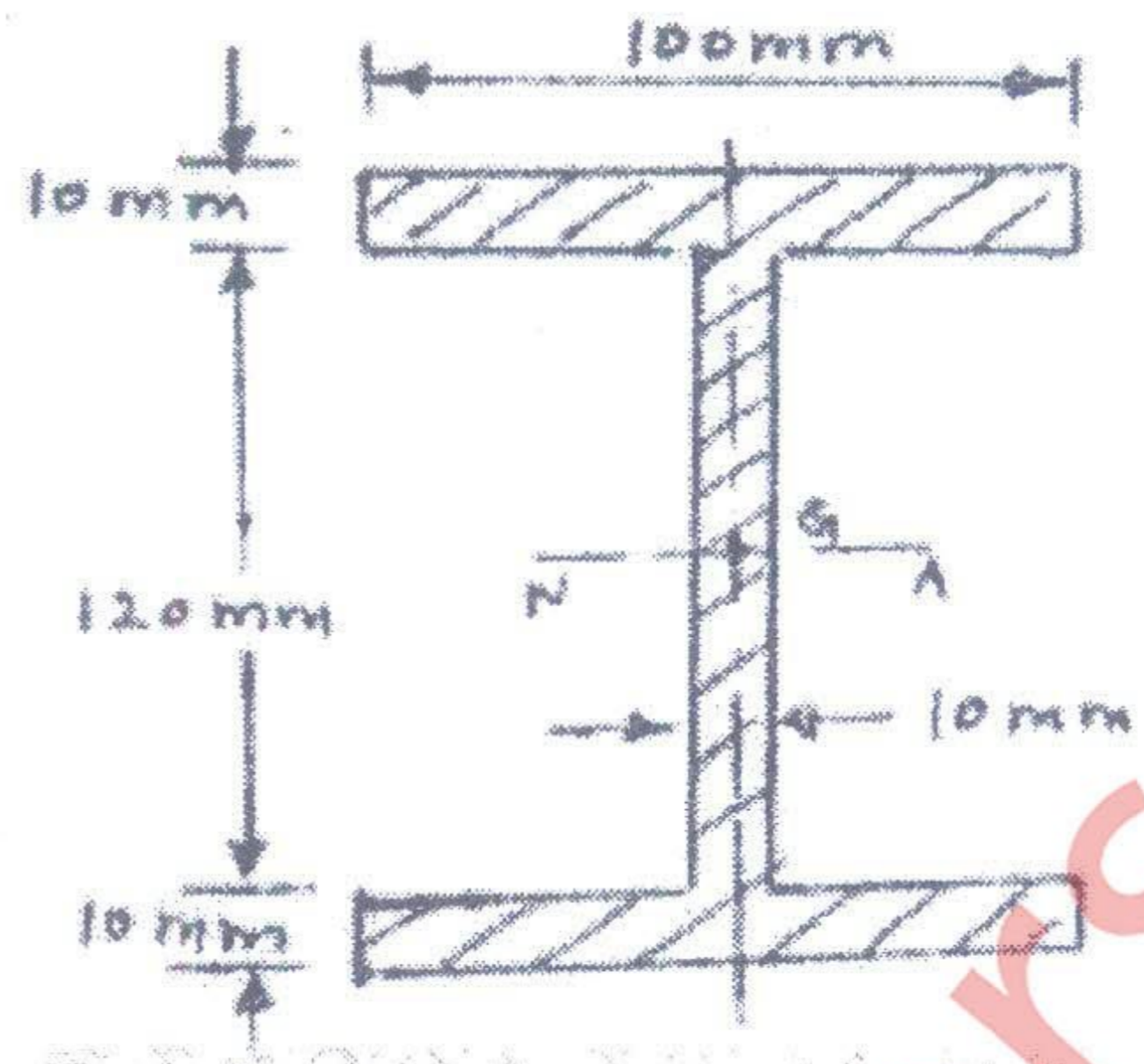

Q.6 a) A steel rod consist of two equal portions each 1 meter long is as shown find the total strain energy of the rod when it is subjected to an axial pull of 150 KN. Take  $E=200 \times 10^3 \text{ N/mm}^2$

10

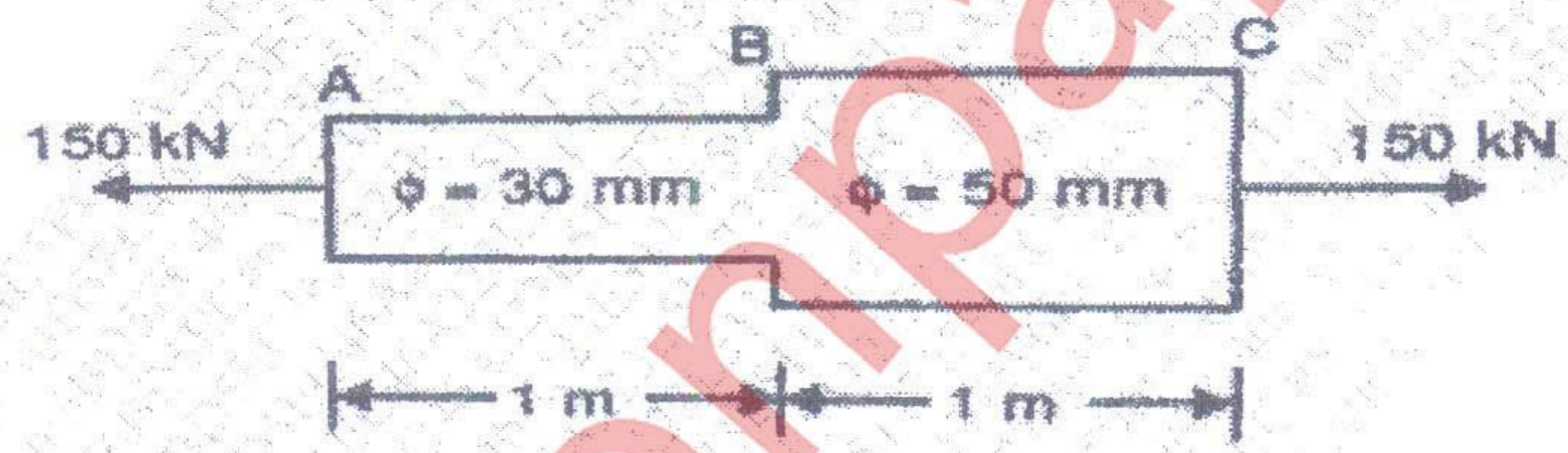

b) An unknown weight falls by 22 mm on to a collar rigidly connected to the lower end of the vertical bar 3 m long and  $500 \text{ mm}^2$  in section. If the maximum instantaneous extension is known to be 2.5 mm, find the corresponding stress and the magnitude of the falling weight. Take  $E = 2 \times 10^5 \text{ N/mm}^2$ .

10