

(3 Hours)

Max. Marks: 80

Note:

1. Question 1 is Compulsory
2. Solve any three from remaining five
3. Figures to right indicate full marks
4. Assume suitable data if necessary

- Q.1
- a) Explain an algorithm for hidden surface removal 5
  - b) Explain reflection with respect to 3D transformation 5
  - c) Explain the significance of rapid prototyping in product development and testing 5
  - d) Explain the roughing and finishing canned cycle for turning. 5
- Q.2
- a) Plot the bezier curve having end points  $P_0(1, 1)$  and  $P_3(3, 1)$ . The other control points are  $P_1(2, 1)$  and  $P_2(4, 3)$ . Also find the midpoint of the curve. 10
  - b) Explain Fused Deposition Modelling 10
- Q.3
- a) Write a complete part program to machine the external contour for the component shown. 10

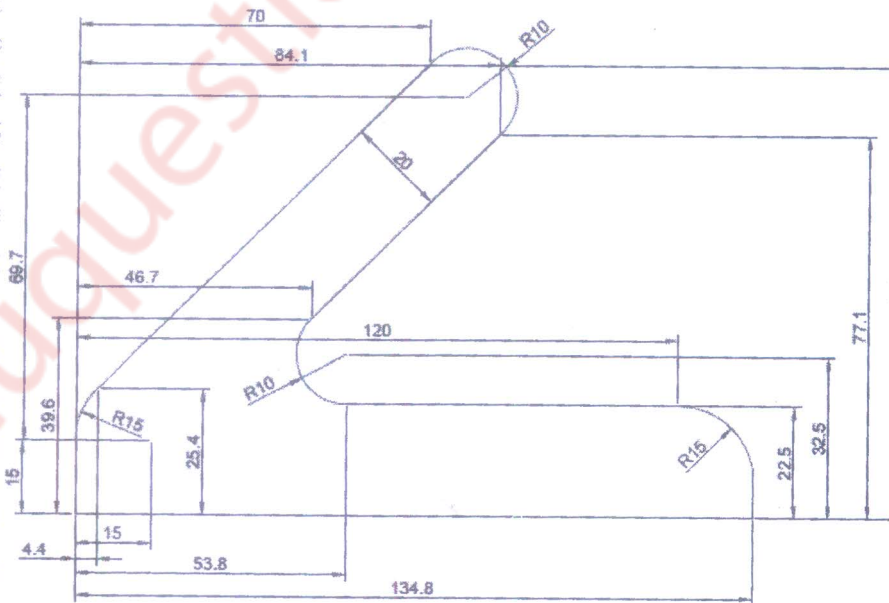

b) Explain Adaptive control system by explaining ACC and ACO 10

Q.4 a) A rectangle ABC has vertices A (5, 10), B (20, 10) and C (20, 20). This triangle is to be reflected about a line P (25, 20) and Q (10, 30). Determine the new triangle position. 10

b) Explain the procedure of kinematic analysis of a structural system with an example. 10

Q.5 a) Write a part program in APT for the component shown in Fig using end mill cutter of 20mm diameter. Clearly show the axes system chosen with a sketch and the direction of the cutter for the motion statements. 10

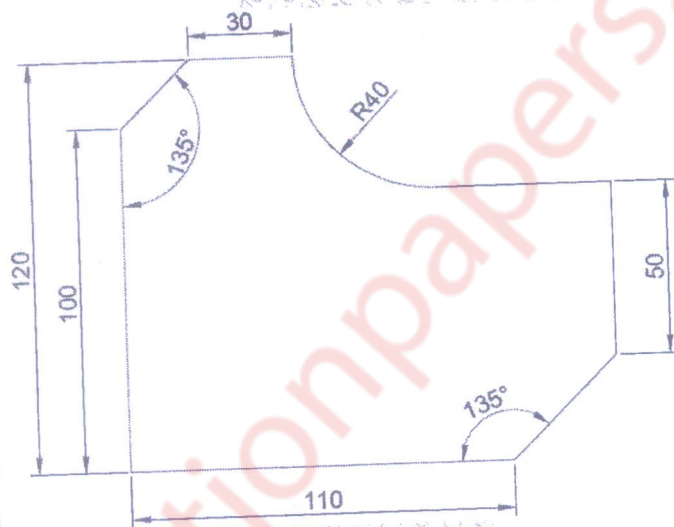

b) Explain the basic components of CIM system. 10

Q.6 Write short note on any Four: 20

- a) Benefits of AI
- b) Constructive solid geometry and Boundary representation
- c) Feedback Devices
- d) Advantages of Computer aided part programming as compared to manual part programming
- e) Photolithography

\*\*\*\*\*